



Allen-Bradley

ControlNet Communication Interface Module

1770-KFC15

User Manual

**Rockwell
Automation**

Important User Information

Solid state equipment has operational characteristics differing from those of electromechanical equipment. *Safety Guidelines for the Application, Installation and Maintenance of Solid State Controls* (Publication SGI-1.1 available from your local Rockwell Automation sales office or online at <http://www.ab.com/manuals/gi>) describes some important differences between solid state equipment and hard-wired electromechanical devices. Because of this difference, and also because of the wide variety of uses for solid state equipment, all persons responsible for applying this equipment must satisfy themselves that each intended application of this equipment is acceptable.





In no event will Rockwell Automation, Inc. be responsible or liable for indirect or consequential damages resulting from the use or application of this equipment.

The examples and diagrams in this manual are included solely for illustrative purposes. Because of the many variables and requirements associated with any particular installation, Rockwell Automation, Inc. cannot assume responsibility or liability for actual use based on the examples and diagrams.

No patent liability is assumed by Rockwell Automation, Inc. with respect to use of information, circuits, equipment, or software described in this manual.

Reproduction of the contents of this manual, in whole or in part, without written permission of Rockwell Automation, Inc. is prohibited.

Throughout this manual we use notes to make you aware of safety considerations.

WARNING 	Identifies information about practices or circumstances that can cause an explosion in a hazardous environment, which may lead to personal injury or death, property damage, or economic loss.
IMPORTANT	Identifies information that is critical for successful application and understanding of the product.
ATTENTION 	Identifies information about practices or circumstances that can lead to personal injury or death, property damage, or economic loss. Attentions help you: <ul data-bbox="327 1091 564 1187" style="list-style-type: none">• identify a hazard• avoid a hazard• recognize the consequence
SHOCK HAZARD 	Labels may be located on or inside the equipment to alert people that dangerous voltage may be present.
BURN HAZARD 	Labels may be located on or inside the equipment to alert people that surfaces may be dangerous temperatures.

The 1770-KFC15 communication interface module provides a communication link between a ControlNet cable system and devices with a serial or parallel port, such as programming terminals, portable computers, and other serial/parallel devices.

Purpose of the Manual

Throughout this manual we refer to the 1770-KFC15 communication interface module as simply ‘the module’.

Use this manual to:

- install and configure the module
- understand how the module communicates on the network (procedures and protocols)
- troubleshoot for problems

Related Publications

These publications contain information related to the 1770-KFC15 Communication Interface module:

Publication Title	Publication Number
ControlNet Cable System Planning and Installation Manual	CNET-IN002
ControlNet Cable System Component List	AG-PA002
DF1 Protocol and Command Set Reference Manual	1770-RM516
Industrial Automation Wiring and Grounding Guidelines	1770-4.1
PLC-5 Family Programmable Controllers Hardware Installation Manual	1785-6.6.1

Related Products

The module creates an interface between the ControlNet cable system and devices with a serial or parallel port. It has been verified to work with these products:

- Allen-Bradley ControlNet taps (1786-TPR, 1786-TPS, 1786-TPYR, and 1786-TPYS)
- Allen-Bradley high voltage AC and DC type repeaters (1786-RPT and 1786-RPTD)
- Allen-Bradley PLC-5 programmable controllers (1785-L20C15, -L40C15, -L60C15, -L80C15)
- Allen-Bradley computer interface cards (1784-KTC15 and 1784-KTCX15)
- Allen-Bradley 1794 Flex I/O Adapters (1794-ACN15, 1794-ACNR15)
- Allen-Bradley 1771 I/O Adapters (1771-ACN15, 1771-ACNR15)
- Allen-Bradley ControlLogix ControlNet Bridge Module (1756-CNB and 1756-CNBR)
- Rockwell Software's RSLogix 5, RSView 32, RSLinx, RSNetWorx, RSLogix 500, RSLogix 5000
- Network Access cable (1786-CP)

Other ControlNet devices and software that comply with the ControlNet Network specifications can also be used with the module.

Terms and Abbreviations

This term:	Means:
1747-KFC15	SLC-based module
1756-CNB	a 1756-CNB or 1756-CNBR module; a ControlLogix backplane to ControlNet bridge
1770-KFC15	referred to herein as the module
a.k.a.	also known as
ACK	a DF1 or ControlNet acknowledgement
ControlNet	<p>the communication architecture that allows the exchange of messages between devices that follow the ControlNet specifications</p> <p>It is a real-time, control-layer network that provides high-speed transport for both time-critical I/O and messaging data. A ControlNet cable system can be either single or redundant media.</p>
DF1	DF1 protocol is an Allen-Bradley RS-232 proprietary data-link layer protocol that combines features of subcategories D1 (data transparency) and F1 (two-way simultaneous transmission with embedded responses) of ANSI x3.28 specification. The KFC uses DF1 protocol to communicate on the serial port.
DH+	Data Highway Plus network; existing Allen-Bradley peer-to-peer network for messaging and program upload/download
DH+ PCCC message	a PCCC message that originated from a device on a DH+ network
DHRIO	Data Highway and Remote I/O
DST	the destination address on a DF1 link
full duplex	simultaneous send/receive between devices, point-to-point
half duplex	data transmission in one direction at a time, usually point-to-multipoint
NAK	a DF1 negative acknowledgement
NAP	n etwork a ccess p ort; input/output (RJ-45 style) connector for a programming terminal to gain full access to the network
network	a collection of connected nodes (end devices). The connection paths between any pair of nodes can include repeaters, routers, bridges and gateways.
network address	the network address of a node on the ControlNet cable system. This address must be in the range of 1 to 99 (decimal) and be unique to that subnet. A subnet can contain a maximum of 99 nodes.
new KFC	Version 4.2 or later of the KFC firmware
node	any physical device connecting to the ControlNet cable system that requires a network address in order to function on the network.
NUT	n etwork u pdate t ime; the rate at which access to the ControlNet network is granted

This term:	Means:
old KFC	Any 1747-KFC15 or 1770-KFC15 firmware released before v4.2, including version 2.2 (a.k.a. version B/B) and older firmware
parallel port	input/output port for a device that transmits multiple data and control bits over wires connected in parallel
PCCC	Programmable Controller Communication Commands; an Allen-Bradley communication protocol used on the Data Highway Plus network
repeater	a two-port active physical layer component that reconstructs all traffic it hears on one network segment side and retransmits it to another network segment side. Repeaters allow for extensions in network distance, conversion to alternate media (coaxial cable, fiber, etc.) and altering the topology of the network.
RIO	Remote Input/Output; an Allen-Bradley remote input/output link that supports remote, time-critical, I/O and control communication between a master PLC controller and its remote I/O and adapter mode slave processors
RS-232C port	a serial port that complies with accepted industry standards for serial communications connections
SRC	The source address on a DF1 link
segment	trunkline sections connected via taps with terminators at each end, and with no repeaters
serial port	input/output connector for a device that transmits data and control bits sequentially over a single transmission line. (See RS-232C port.)
standard PCCC message	A PCCC message that originated from a device that is not on a DH+ network
subnet	network segments connected by repeaters to make up one ControlNet network
tap	the connection device between any ControlNet device and the trunkline. A tap is required for each node and for both sides of each repeater.
terminator	a special circuit that prevents signal reflections from occurring at the end of a cable
trunkline	the bus or central part of a cable system
trunkline section	a length of trunkline cable between any two taps

ATTENTION**Environment and Enclosure**

This equipment is intended for use in a Pollution Degree 2 industrial environment, in overvoltage Category II applications (as defined in IEC publication 60664-1), at altitudes up to 2000 meters without derating.

This equipment is considered Group 1, Class A industrial equipment according to IEC/CISPR Publication 11. Without appropriate precautions, there may be potential difficulties ensuring electromagnetic compatibility in other environments due to conducted as well as radiated disturbance.

This equipment is supplied as “enclosed” equipment. It should not require additional system enclosure when used in locations consistent with the enclosure type ratings stated in the Specifications section of this publication. Subsequent sections of this publication may contain additional information regarding specific enclosure type ratings, beyond what this product provides, that are required to comply with certain product safety certifications.

NOTE: See NEMA Standards publication 250 and IEC publication 60529, as applicable, for explanations of the degrees of protection provided by different types of enclosure. Also, see the appropriate sections in this publication, as well as the Allen-Bradley publication 1770-4.1 (“Industrial Automation Wiring and Grounding Guidelines”), for additional installation requirements pertaining to this equipment.

WARNING**Preventing Electrostatic Discharge**

This equipment is sensitive to electrostatic discharge, which can cause internal damage and affect normal operation. Follow these guidelines when you handle this equipment:

- Touch a grounded object to discharge potential static.
- Wear an approved grounding wrist strap.
- Do not touch connectors or pins on component boards.
- Do not touch circuit components inside the equipment.
- If available, use a static-safe workstation.
- When not in use, store the equipment in appropriate static-safe packaging.

Notes:

Chapter 1

ControlNet System Overview

Overview of ControlNet. 1-1
Communication Protocol. 1-1
Understanding the ControlNet Architecture. 1-2
Planning the Host Cable System 1-3

Chapter 2

Introducing the Module

Overview of the 1770-KFC15 Module 2-1

Chapter 3

Installing the Module

Electrostatic Damage. 3-1
Overview of the Installation Procedure 3-2
 Connecting to a Host through the RS-232C Port 3-2
 RS- 232C Baud Rates 3-2
 Cables. 3-3
 Connector 3-3
 RS-232C Activity Indicator. 3-3
Connecting to a Host through the Parallel Port. 3-4
 Cables. 3-4
 Connector 3-4
 Parallel Port Activity Indicator 3-4
Connecting a Device to the Network Access Port. 3-4
 Cables. 3-4
Connecting to the AC Power Supply 3-5
Connecting to the ControlNet Cable System 3-6
Attaching the Module to a Wall or Mounting Bracket. 3-7

Chapter 4

Configuring the Module

Overview of Configuration Procedures	4-1
Displays	4-1
Pushbuttons	4-2
Configuring the Module by Using Pushbuttons	4-3
Verifying the Communication Parameters	4-13
1770-KFC15 Diagnostic Counters	4-14
Reading 1770-KFC15 Counters With a Diagnostic Command	4-14

Chapter 5

Understanding the Extra-hop Feature

Method 1: No Configuration	5-2
Method 2: Configure a Path Using the Pushbuttons and 7-segment Display	5-3
Path Length	5-3
Port Numbers	5-4
Address/Slot Number	5-5

Chapter 6

Communicating with the Module

DF1 Communication	6-1
Serial Communication	6-2
Parallel Communication	6-4
Embedded Responses	6-5
Message Reply Time-out	6-6
Default DF1 Address	6-6
DF1 SRC and DST Address	6-7
RSLinx DF1 Driver Anomaly	6-8
Auto-recovery	6-9
Message Buffers	6-9

Chapter 7

Troubleshooting the Module

Interpreting the Status LEDs	7-1
------------------------------------	-----

Appendix A

Product Specifications

Appendix B

Cabling and Pinouts

Cabling and Pinouts for RS-232C Connection	B-1
Cabling and Pinouts for Parallel Port Connection	B-6

Appendix C

DF1 Diagnostic Command Support

Diagnostic Loop	C-2
Diagnostic Read Counters	C-2
Diagnostic Status	C-5
Diagnostic Counter Reset	C-6
1747-KFC15 Meters	C-6

Appendix D

Writing a Parallel Communication Driver

DF1 Parallel Communication	D-1
Data Transmission	D-4

Index

ControlNet System Overview

This chapter briefly describes the network architecture. For detailed information, refer to the ControlNet Cable System Planning and Installation Manual, CNET-IN002.

Overview of ControlNet

ControlNet combines the capabilities of Data Highway Plus and Remote I/O in a single local area network (LAN). It provides time-critical communication capabilities for real-time control, and messaging services for peer-to-peer communication.

Several devices can be connected to the ControlNet cable system including personal computers, programmable logic controllers, modems, variable speed drivers, operator interfaces, and other devices with direct ControlNet cable system connections. To connect directly, devices must be able to handle ControlNet communication protocol. The PLC-5/40C15 is such a device. Some equipment, however, requires an intermediate device to act as an interface between it and the network. The 1770-KFC15 module acts as this interface. Refer to Chapter 2 for more information on the 1770-KFC15 module.

Physical Characteristics

The physical network media for ControlNet is coaxial cable with redundant media connections as an option. The allowable length of a cable segment in the network depends on the number of nodes in the segment. A single subnet can accommodate several segments by using repeaters.

Communication Protocol

The most important function of the ControlNet network is to transport time-critical control information. Other information is also transported but is not allowed to interfere with time-critical messages. This is done through a communication protocol that determines access to the ControlNet network using a time-slice access algorithm. Access to the network occurs at a user-configurable period called the network update time (NUT).

The NUT is divided into three parts:

Scheduled—every node is guaranteed one opportunity to transmit

Unscheduled—remaining time is divided among all nodes on a round-robin basis. This rotation of access repeats until the time allotted to the unscheduled portion is used up. The amount of time available for the unscheduled portion is determined by the traffic load of the scheduled portion.

Maintenance—the moderator node (the one with the lowest address) transmits information to keep the other nodes synchronized in time

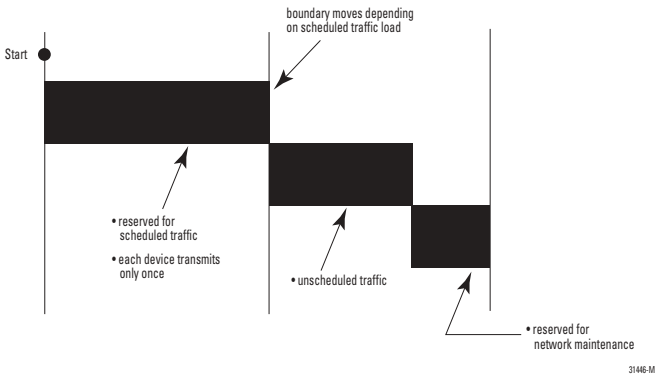

The part of the interval in which any given data will be sent depends on its priority, of which there are two levels:

Scheduled Data—time-critical information that must be sent at a fixed and repetitive rate is sent exclusively in the scheduled portion of the NUT.

Unscheduled Data—information that does not have strict time constraints. It is sent only if no data is waiting to be sent at a higher priority.

The 1770-KFC15 module supports non-time-critical messaging and programming data, and sends *only* unscheduled data.

Understanding the ControlNet Architecture

The ControlNet cable system provides the flexibility to design a communication network for your application. To take advantage of this flexibility, you should spend enough time planning how to install your cable system *before* assembling any of the hardware. Consult the ControlNet Cable System Planning and Installation Manual, CNET-IN002, for a full description of the cable system and detailed installation instructions.

Planning the Host Cable System

A serial or parallel host (computer, controller, or other device) can connect to the module through either the parallel or RS-232C serial port. Both ports on the module cannot be active at the same time so you must decide which port is the most appropriate for your application. This decision determines the cabling and hardware requirements for your system.

Communication between either a parallel or serial host and the module is carried out using Allen-Bradley's proprietary DF1 protocol. DF1 is a full- or half-duplex protocol that carries messages intact over a link. The protocol delimits messages, detects and signals errors, retries after errors, and controls message flow. In a typical network, as discussed in this manual, the host is the master station and the module is the slave. For a complete description of the DF1 protocol, refer to the DF1 Protocol and Command Set Reference Manual, 1770-RM516.

IMPORTANT

Firmware V4.2 and later **do not** support the parallel port.

Planning for an RS-232C Serial Port

Serial port communication can take place in either full- or half-duplex mode. If a single module per serial host is used, either half-duplex or full-duplex communication can take place. Since it is faster and easier to configure, full-duplex is always preferred over half duplex.

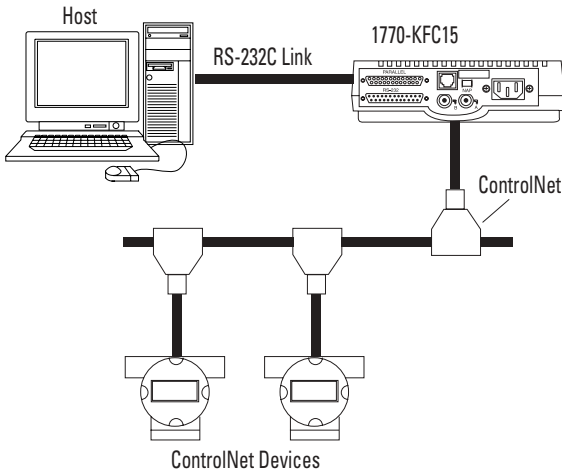

31348-M

If more than one module is connected to a host, only half-duplex communication can occur and half-duplex modems must be used between the module and the host. See Figure 1.1 on page 1-4. Determine how many modules you will need before planning the layout of the host system because cable length and baud rate are affected as well. See Appendix B for details.

Figure 1.1 Connecting Multiple Modules to One Host By Using Modems

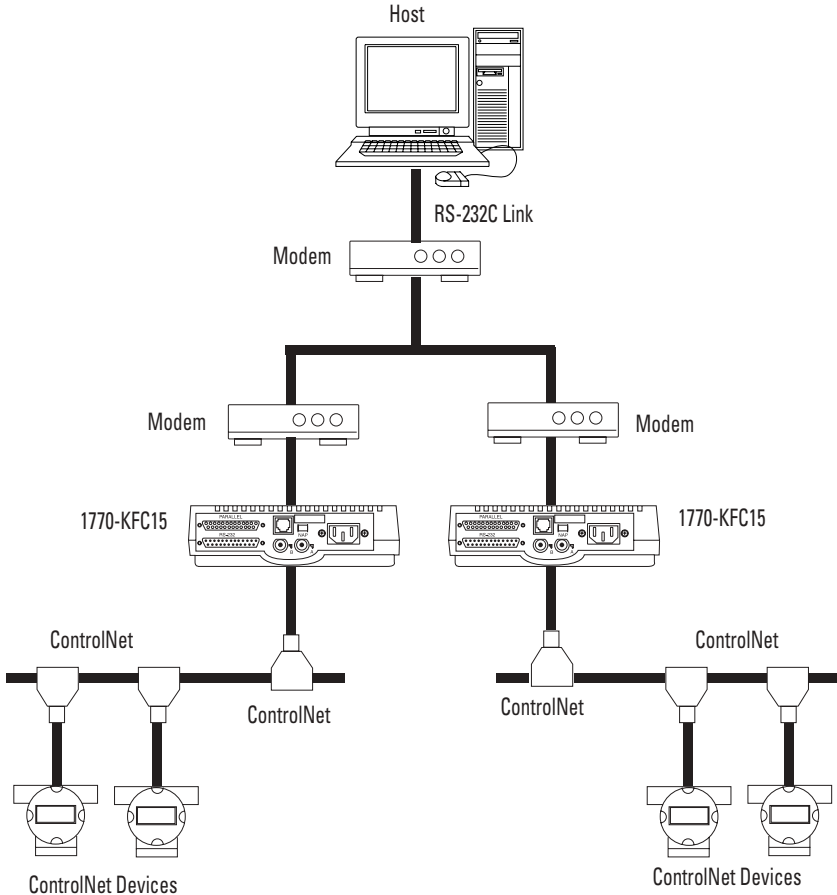

Planning for a Parallel Port (Not supported in V4.2 and later)

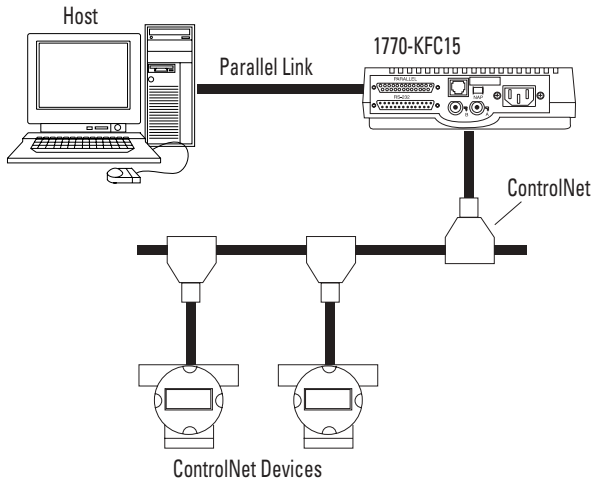

31347-M

The parallel port interface, not supported in V4.2 or later, consists of eight, bidirectional data lines and nine handshaking lines. Consider the following requirements when planning for a parallel port connection.

- Data transfers occur in half-duplex mode between the parallel host and the module.
- Data transfer mode is configured using pushbuttons on the module and can be bytes (8 bits) or nibbles (4 bits).
- When connection is via the parallel port you can have only one module per host.
- The maximum recommended cable length between the module and the parallel host is 3 m (10 ft).
- The cable between the module and the parallel host must be shielded.

For detailed cabling and pinout information see Appendix B, Cabling and Pinouts. For a discussion of data transfer modes and other communication issues, see Chapter 5, Communicating with the Module and Appendix D, Writing a Parallel Communication Driver.

Notes:

Introducing the Module

Overview of the 1770-KFC15 Module

The module enables you to connect RS-232 devices directly to ControlNet. Device types requiring connection to the ControlNet cable system are varied, including multi-vendor automation equipment, personal computers, mini-computers, and modems.

Figure 2.1 Top View

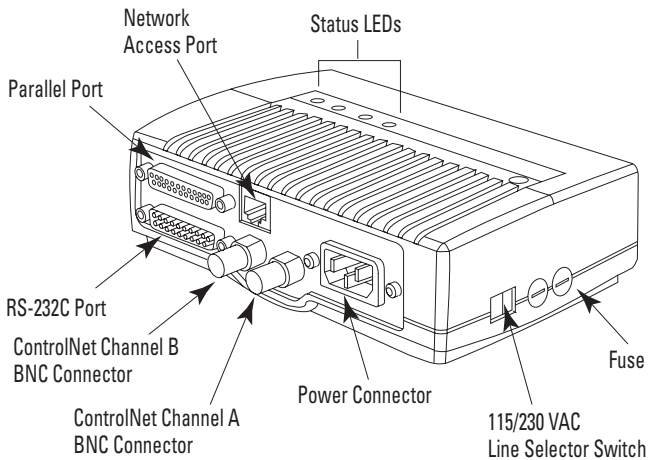

31352-M

Figure 2.2 Sample Connections

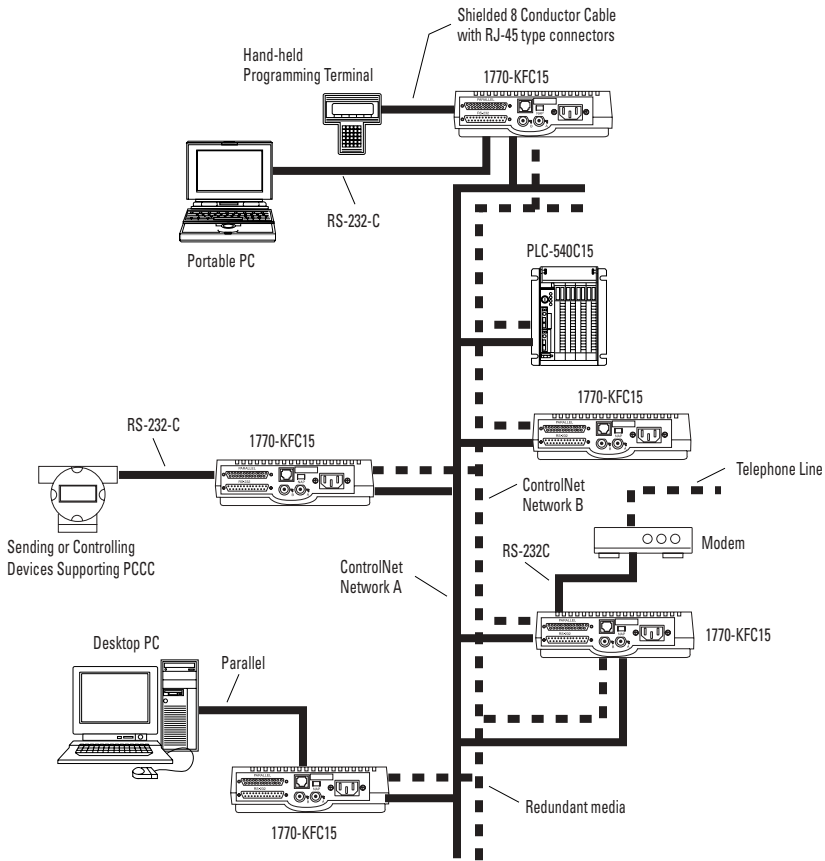

31351-M

The module connects to the ControlNet from one (Channel A) or both of its two BNC connectors via a standard, one-meter, ControlNet coaxial tap. For redundant media, both connectors are used. See Figure 2.2.

The module has three ports for device connections:

RS-232C serial port—provides half- or full-duplex communication with a serial node such as a host computer, an intelligent controller or a modem

parallel port—provides half-duplex communication with a parallel host such as a computer (**only** in versions prior to V4.2)

network access port—lets you connect a programming terminal or other device to the module for full network access without disrupting the cable wiring

The serial and parallel ports use DF1 protocol while the remaining network access port handles ControlNet packets directly.

Status, Host, and ControlNet LEDs on the top of the module indicate current operating conditions of the unit and communication activities taking place through the ports.

Figure 2.3 Bottom View

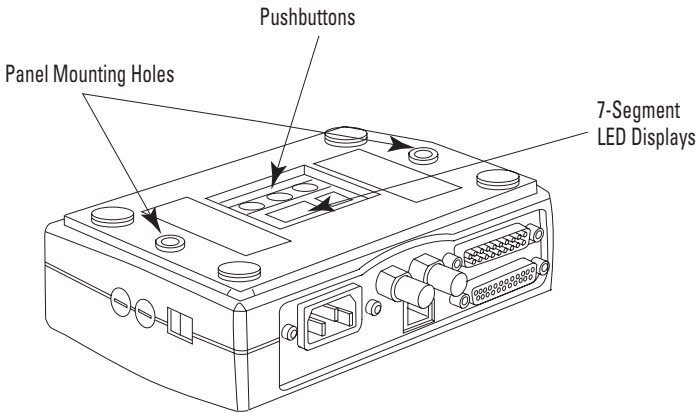

31353-M

The module is configured by using the pushbuttons and seven-segment LED display in the configuration panel on the bottom of the unit as shown in Figure 2.3.

Use the pushbuttons and seven-segment LEDs in the configuration panel on the bottom of the unit to set and verify the ControlNet address for the module and all serial RS-232C or parallel communication parameters.

Compatibility

The module is compatible with the following interfaces:

- RS-232C serial ports
- IBM PC-compatible parallel ports
- IBM Type 1 PS/ 2-compatible parallel ports
- ControlNet devices that comply with the ControlNet specification
- programming terminal products that comply with ControlNet specifications for the Network Access Port

Notes:

Installing the Module

Use this chapter to install the module. This chapter describes:

- an overview of the general installation procedure
- how to connect the module to a host through the RS-232C serial port
- how to connect the module to a host through the parallel port
- how to connect the module to a host through the isolated network access port (NAP)
- how to connect the module to the ControlNet cable system
- how to attach the module to a wall or mounting bracket

Pinout and wiring details are provided in Appendix B, Cabling and Pinouts. Read this if you need to construct cables. If a tap is not available on the ControlNet cable system for the module, refer to the ControlNet Cable System Planning and Installation Manual, CNET-IN002, to determine if your cable system can accommodate another node and to plan where to mount the tap, then follow the mounting instructions at the end of this chapter.

Electrostatic Damage

ATTENTION

Electrostatic discharge can damage semiconductor devices inside the module. To guard against electrostatic damage wear an approved wrist strap grounding device, or touch a grounded object to rid yourself of electrostatic charge before handling the products.

Overview of the Installation Procedure

1. Make sure that the ControlNet cable system can accommodate additional nodes (one per module being installed).
2. Determine the placement of the module (desk, wall or mounting bracket).
3. Connect the module to the host through either the parallel or serial port, or through the network access port.
4. Connect the module to a power supply as detailed later in this chapter.
5. Configure the communications parameters on the module as detailed in Chapter 4, Configuring the Module.
6. Connect the module to the network by using taps.

IMPORTANT

Placement of the module will determine if mounting comes before or after connecting the cables.

Connecting to a Host through the RS-232C Port

A single, full- or half-duplex, RS-232C serial port using the DF1 protocol provides communications with either a host computer or intelligent controller. For an explanation of full- and half-duplex see Chapter 5, Communicating with the Module.

RS- 232C Baud Rates

The module supports the following baud rates: 300, 600, 1200, 2400, 4800, 9600, 19200 and 38400.

Cables

Cabling for the RS-232C connector will vary depending on your application. You can use either a 3-wire cable or a cable with handshaking lines. For wiring diagrams, see Appendix B, Cabling and Pinouts. The maximum recommended cable lengths are:

- baud rates less than or equal to 19200 15 m (50 ft)
- baud rates equal to 38400 7.5 m (25 ft)

Connector

The RS-232C interface connector at the module end is a DB-25 male connector (DTE) with EIA (Electronics Industries Association) standard pinout as outlined in Appendix B, Cabling and Pinouts.

Secure connectors by tightening screwlocks with 3.5 in.-lbs torque until snug.

RS-232C Activity Indicator

The HOST LED will flicker when the module is receiving or transmitting data over the RS-232C interface. The LED will be off when no data activity is occurring over the RS-232C interface.

Connecting to a Host through the Parallel Port

IMPORTANT

The parallel port is not supported in V4.2 and later.

The parallel port interface is compatible with the parallel ports of IBM PCs, and also with bidirectional parallel ports of PS/2 computers. Two data transfer modes are available to provide compatibility, byte and nibble (4 bit). Specify the mode of parallel port operation using the push buttons on the configuration panel. Configuration is discussed in Chapter 5, Communicating with the Module. In either case, the appropriate software driver is required on the host computer.

Cables

The maximum cable length recommended is 3 m (10 ft). The cable should be shielded.

Connector

The parallel port interface connector is a DB-25 female connector with a standard Centronics pinout. See Appendix B, Cabling and Pinouts, for cabling and pinout details.

Secure connectors by tightening screwlocks with 3.5 in.-lbs torque until snug.

Parallel Port Activity Indicator

The HOST LED will flicker when the module is receiving or transmitting data over the parallel interface. The LED will be off when no data activity is occurring over either the RS-232C or the parallel port interface.

Connecting a Device to the Network Access Port

Use the isolated network access port to connect a transitory device, such as a programming device, to the module.

Cables

You must use the Allen-Bradley Network Access Cable (catalog no. 1786-CP).

Connecting to the AC Power Supply

The module contains an internal transformer that allows you to switch between 115V ac or 230V ac at 60 Hz or 50 Hz respectively.

ATTENTION



The module does not have an ON/OFF switch so power is applied to the module as soon as you plug it in. For this reason you must select the voltage **before** plugging in the module to prevent damaging the unit.

WARNING



Ensure that the equipment is connected to a properly grounded AC 115/230V 50/60 Hz supply according to applicable local requirements and codes.

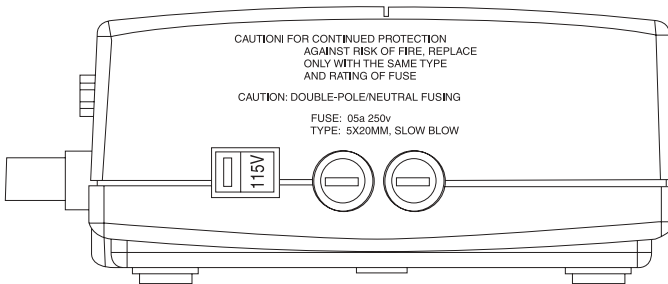

31355-M

To select the input voltage:

1. Locate the red voltage selector switch on the side of the module beside the fuses.
2. Slide the switch to the left for 115V ac or to the right for 230V ac. The selected voltage is visible in the indented part of the switch.
3. Plug in the module.

Connecting to the ControlNet Cable System

To connect the module to the ControlNet cable system use an approved ControlNet tap. Refer to the ControlNet Cable System Planning and Installation Manual, CNET-IN002, for complete instructions on connecting the tap to the cable system.

ATTENTION



If the module is connected to a cable system that does not support redundant media, the tap dropline should be connected to the BNC connector labeled channel A. The channel B connector should be unused. If the cable system is redundant, the module should be connected such that all devices on the network use the same cable for the same channel. The channel A connector on all products should be connected to the same cable. The same applies for the channel B connectors.

To connect the module to the tap do the following:

1. If the module is not the last device in the segment:
 - Connect the tap to the coaxial trunkline.
 - Connect the dropline BNC to the channel A BNC of the module.
2. If the module is the last device in the segment, install a terminator at the end of the cable segment, then follow the instructions in step 1.
3. If using redundant media, repeat either step 1 or step 2 for channel B of the module.

Attaching the Module to a Wall or Mounting Bracket

You can set the module on any flat surface, such as a desk or shelf, or attach it to a mounting bracket or directly to a wall for vertical placement. Use the two #10-32 threaded inserts on the unit if you are mounting it vertically. Maintain a 1" clearance on all sides of the module.

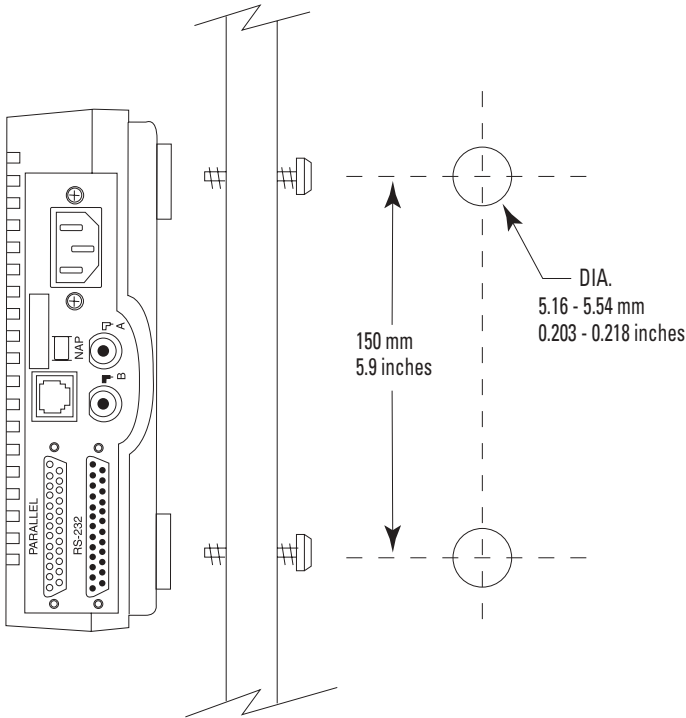

31357-M

To attach the module to a wall:

1. Mark the position of the screw inserts on the surface to which it is to be attached.
2. Drill holes through the surface, as shown in the drawing above.
3. Insert screws from the back of the surface, through the holes and into the screw inserts, then tighten.

IMPORTANT

The configuration pushbuttons and displays will not be accessible or visible if the module is wall or bracket mounted.

Notes:

Configuring the Module

Use this chapter to configure the module's communication parameters via the pushbuttons and seven-segment displays in the configuration panel on the bottom of the module.

Overview of Configuration Procedures

The module has two modes of operation, *run mode* and *configuration mode*. During normal operation the module functions in run mode. To change the communication parameters the unit must be in configuration mode.

Any changes made to the communication parameters take effect as soon as they are saved and the unit returns to run mode. While in configuration mode the module continues to communicate according to its current settings. This allows you to view the current settings without interrupting the operation of the unit.

IMPORTANT

Verify all parameter settings before connecting the module to the network. Incorrect settings may cause unreliable and unpredictable operation of the network.

Parameter settings are saved in non-volatile memory so that you do not lose them even if power to the module is interrupted. When the module is in run mode, the seven-segment display is off to conserve power.

IMPORTANT

If the module displays symbols other than those shown in this chapter, it is malfunctioning. Contact your Allen-Bradley representative to arrange to return the unit for servicing.

Displays

The following drawing shows the displays on the configuration panel on the bottom of the module. The left display (one digit) shows the number of the parameter being configured. The two right displays (two digits) show the current setting for that parameter. Communication parameters are configured in two menus, a *main menu* for basic parameters, and a *sub-menu* for more advanced parameters for the RS-232C serial port.

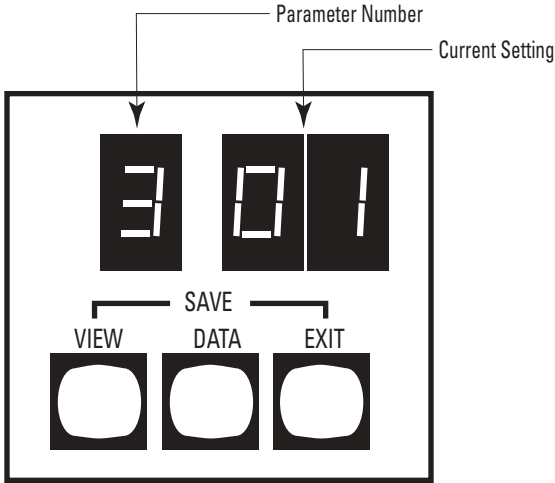

31358-M

Pushbuttons

The operation of the three pushbuttons labelled VIEW, DATA, and EXIT in the configuration panel are described in this table.

Pressing this button or button combination:	Performs this task:
VIEW	<p>In run mode, places the module in configuration mode. This is the only button that has a function in run mode.</p> <p>In configuration mode, cycles through the possible communication parameters (displayed on the left digit).</p> <p>If you hold the button down for more than 1 second, the parameter number advances automatically.</p>
DATA	<p>In configuration mode, cycles through the possible communication settings for the parameter shown on the left. The data is displayed on the right two digits. If you hold the button down for more than 1 second, the settings advance and accelerate automatically. When the left display shows A, C, or P, press DATA to enter the sub-menu.</p>

Pressing this button or button combination:	Performs this task:
EXIT	In configuration mode at the main menu, returns the module to run mode without saving any changes. From the sub_menu, returns to the main menu.
VIEW + EXIT	In configuration mode , saves all configuration changes, and returns the module to run mode from either menu. The module will begin operating with the new configuration as soon as it returns to run mode.
VIEW + DATA	In configuration mode , resets all communication parameters to their factory defaults. The changes do not take effect until the configuration is saved, and the module returns to run mode, i.e., until VIEW and EXIT are pressed simultaneously. If only EXIT is pressed the unit returns to run mode without making the factory default changes.

Configuring the Module by Using Pushbuttons

Before configuring the module, you should determine the parameter settings the network requires. If they differ from the factory defaults shown in the parameter tables on the following pages, use the directions below to change them.

For normal operation, you must configure the basic communication parameters. For special communication needs you can configure the advanced communication parameters, which provide more flexibility in the operation of the module.

While you are changing the parameters in configuration mode, the module continues to operate using its current settings. The changed parameter settings do not take effect until they are saved and the module returns to run mode.

Viewing Basic Parameter Settings

To view the current parameter settings:

1. Press the VIEW button to enter configuration mode. The first parameter number is displayed on the left display, with its current setting in the right two displays.
2. Press VIEW to display the next parameter and its current setting, or hold it down to cycle through the communication parameters. When the last parameter is reached, the configuration number wraps back to the start.
3. Press EXIT to return the module to run mode without changing parameters.

Configuring the Basic Parameters

The basic parameters are numbered zero to eight. The letters A, C, F, and P also come up on the seven-segment LEDs as you cycle through them as described above. The letter A lets you into the sub-menu that contains the advanced communication parameters. The settings displayed beside letter F are the series and revision number of the module.

To configure the basic parameters:

1. Press the VIEW button to enter configuration mode.
2. Press VIEW as often as necessary or hold it down until the desired parameter is reached.
3. Once the desired parameter is displayed, press the DATA button to cycle through the available settings. Only valid selections for the given parameter option are displayed.
4. When you have reached the desired data setting, you can press VIEW to display the next parameter.
5. When all relevant parameters have been set, press VIEW and EXIT together to save the parameter settings and return the module to run mode.

The basic communication parameters and their valid settings are described in Table 4.1.

Table 4.1 Basic Communication Parameters



Parameter Number	Parameter	Description	Factory Default
ControlNet			
	Network Address	Auto Addressing (AA) or 01-99 Auto Addressing is not supported in version 4.2 or later. The factory default for V4.2 is 99.	AA or 99
Port			
	DF1 Port	Serial (00), Parallel (01) Parallel port is not supported in version 4.2 or later.	00

Table 4.1 Basic Communication Parameters





Parameter Number	Parameter	Description	Factory Default
RS-232C			
	Baud Rate	300 (03), 600 (06), 1200 (12), 2400 (24), 4800 (48), 9600 (96), 19200 (19), 38400 (38) bits/sec	96
	Parity	None (00), Even (01), Odd (02)	00
	Full/Half Duplex	Full duplex (00), Half duplex (01) for serial port only	00
Parallel			
	Parallel Port Transfer	Nibble data transfers to host (01), Byte data transfers to host (02) Parallel port is not supported in version 4.2 or later.	01
DF1			
	Error Detection	BCC Block Check Code (00), or CRC16 Cyclic Redundancy Check (01) For V4.2 and later, the default is CRC (01).	00 or 01

Table 4.1 Basic Communication Parameters







Parameter Number	Parameter	Description	Factory Default
	DF1 Station Address	The station address of this node on the DF1 link. Valid addresses are 00-77 Octal inclusive.	00
	Diagnostic Command Execution	Determines whether PCCC diagnostic commands are executed directly by the KFC15 (01) or passed through to the host computer (00).	01
Other			
	Advanced Parameters Sub-menu	Lets user into the sub-menu to set extra parameters. Press DATA key to enter the Advanced Parameters sub-menu.	N/A
	Firmware Revision (major, minor)	Displays the module series and revision. V4.2 and later displays the revision as numbers, e.g., 4.2. Older revisions display this as letters, e.g., B B.	N/A

Table 4.1 Basic Communication Parameters

Parameter Number	Parameter	Description	Factory Default
V4.2 and later support additional parameters.			
	Counter Sub-menu	<p>Displays diagnostic counter information.</p> <p>Press the DATA key to enter the Counters sub-menu.</p> <p>See the new counter table in Appendix C.</p>	N/A
	Extra Path Sub-menu	<p>Lets the user into the Extra Path sub-menu.</p> <p>Press the DATA key to enter the Extra Path sub-menu.</p> <p>See the Extra-hop section in chapter 5.</p> <p>NOTE: Network paths are made up of hops.</p>	N/A

Configuring the Advanced Communication Parameters

The advanced communication parameters, numbers zero through nine, are in the advanced parameters sub-menu. See Table 4.2 on page 4-9. Sub-menu parameters are followed by a decimal in the display. View them the same way basic parameters are viewed, when you enter the sub-menu.

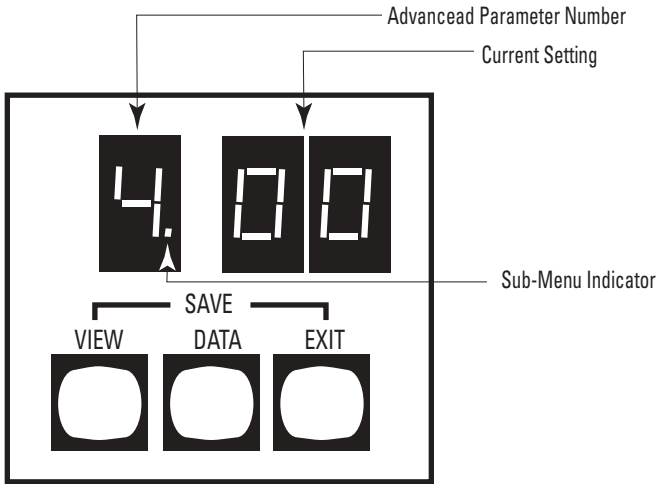

31359-M

1. To enter the sub-menu, press VIEW until parameter A appears in the left display and dashes in the right display, then press DATA.

The number on the left changes from A to 0, and its decimal point lights up, remaining lit as long as you are in the sub-menu.

2. Press VIEW to display the sub-menu parameters, as described for the basic parameters, until you reach one you want to configure.
3. Press DATA to display and cycle through the settings for the advanced parameters until you get to the one you want.
4. Repeat the process until you have completed setting the parameters.
5. Press VIEW and EXIT while in the sub-menu to save the changes and return the module to run mode.

Note: You can press EXIT to return to the main menu from the sub-menu, if necessary. This does not end the configuration session. You can go back to the sub-menu as described in step 1. The changes you have made to advanced parameters are not lost as long as you go through the save and exit procedure, described on page 4-12, when you return the module to run mode.

Table 4.2 Advanced Communication Parameters





Parameter Number	Parameter	Description	Factory Default
	Number of Retries	Number of allowable retries per attempt on the RS-232C link: 00 - 10	02
	Duplicate Message Detection	Disabled (00), Enabled (01). If enabled, the module will acknowledge and discard duplicate messages received on the DF1 link.	01
	DF1 ACK Time-out	The time to wait for an ACK from the host computer. The time is from 0.1 to 5 seconds in 0.1 second increments (01-50). To calculate the time-out, multiply the number in the display by 0.1 second.	10
	Modem Handshaking	Disabled (00), Enabled (01)	00

Table 4.2 Advanced Communication Parameters







Parameter Number	Parameter	Description	Factory Default
	CTS to Transmit Delay	<p>The delay between the CTS signal and the start of transmission. The delay is from 0 to 0.99 seconds in 10 ms (0.01 second) increments.</p> <p>To calculate the delay, multiply the number in the display by 0.01 seconds.</p> <p>This parameter takes effect only when the KFC15 is in half-duplex mode and handshaking is enabled.</p>	No delay (00)
	End of Message to RTS Off	<p>The delay between the end of a message and the KFC15 setting RTS inactive. The delay is from 0 to 0.99 seconds in 10 ms (0.01 second) increments.</p> <p>To calculate the delay, multiply the number in the display by 0.01 seconds.</p> <p>This parameter takes effect only when the KFC15 is in halfduplex mode and handshaking is enabled.</p>	No delay (00)
	Embedded Response Mode	<p>configure the embedded response mode</p> <ul style="list-style-type: none"> • 0 – Auto Detect – Default • 1 – Always send embedded responses • 2 – Never send embedded responses 	0

Table 4.2 Advanced Communication Parameters

Parameter Number	Parameter	Description	Factory Default
	Message Reply Time-out	Used to configure the message reply time-out. This parameter represents time in seconds and has a range of 1 to 99 seconds. The default value is 5 seconds.	5 secs
	Default DF1 Address	Used to configure the default DF1 address. This parameter is a hexadecimal value and has a range of 0 to FF. The value FE is a special value that indicates that the current ControlNet address should be used. The default value is FE. Therefore, the default behavior is to use the ControlNet address just as the old KFC did.	FE
	Auto Recovery	Used to configure the auto-recovery feature. A parameter value of 0 means disabled (the default), and a value of 1 means enabled.	0

Saving Configuration Changes

To save all parameters in both the main menu and the sub-menu in non-volatile memory, press the VIEW and EXIT buttons simultaneously. The module returns to run mode. This ends the configuration session.

If the save is successful, the display will show three dashes for a period of two seconds. When the module returns to run mode, the new configuration takes effect and the display turns off. While most parameters take effect immediately, some, e.g., the ControlNet MAC ID, initiate a reset of the module. After the module resets, the new parameters take effect.

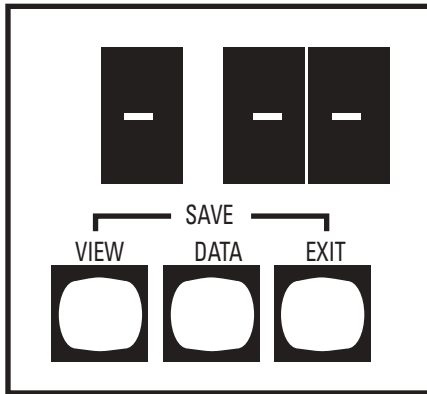

31360-M

If the save is not successful, the module is malfunctioning. The left display will show hardware fault number 6 and the STATUS LED will show solid red. If this happens, contact your Allen-Bradley representative.

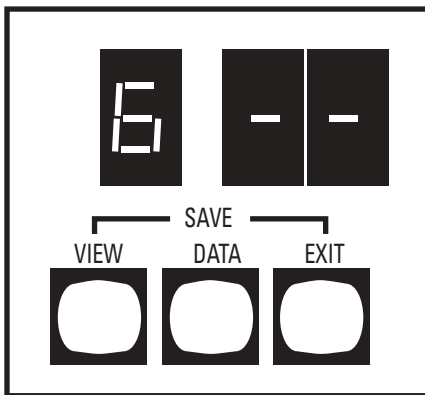

31361-M

Exit Without Saving

To exit without saving while in the main menu, press EXIT. The module returns to run mode from configuration mode without saving any changes. This ends the configuration session and the previous settings will remain in effect.

To return to the main menu from the sub-menu, press EXIT. You can move between the two menus as much as you need to during any given configuration session.

If you exit from the main menu without saving, as described above, any changes made in the sub-menu are not saved. If you save and exit from the main menu, changes made in the sub-menu are saved as well.

IMPORTANT

If the module is left inactive (i.e., with no buttons pressed) in configuration mode for 3 minutes, it returns to run mode. Any changes made since going into configuration mode will not be saved. Also, if power to the unit is interrupted while in configuration mode, any changes made will not be saved.

Setting Factory Defaults

To reset all parameters in both menus to their factory defaults, press the VIEW and DATA buttons simultaneously when in configuration mode. When this button combination is pressed, the module displays the first parameter and its factory default.

To save the factory default parameters, press the VIEW and EXIT buttons simultaneously. If you press only the EXIT button, the unit returns to run mode without changing the parameters to their factory defaults.

Verifying the Communication Parameters

Before connecting the module to the network, cycle through the parameter settings and verify that they are correct. Incorrect settings may cause unreliable and unpredictable operation of the network.

1770-KFC15 Diagnostic Counters

Diagnostic counters can now be accessed on the 7-segment display of the new 1770-KFC15 module. All of the counters, except 0, are 16 bits wide and are displayed in hexadecimal format. Press the [Data] key to toggle between viewing the low byte and high byte. See Table C.6 on page C-4 for a list of counters.

Counter 0 is not really a counter at all; rather it displays the value of the hardware handshake lines.

To view the counters:

1. Press the [View] key until you see a C and 2 dashes {C - -}.
2. Press the [Data] key to enter the counters submenu. Counter 0, the hardware handshake lines, is displayed.
3. Press the [View] key to advance to counter 1. The low byte of Counter 1, the number of DF1 packets sent, is displayed. For example, if 36 packets (24 hexadecimal) have been transmitted, you will see {1. 2 4.}. Notice the decimal points after the 1 and after the 24. The decimal point after the 1 indicates that you are in a submenu. The decimal point after the 24 indicates that the low byte is being displayed.
4. Press the [Data] key to view the high byte of the counter. You see {0. 0 0}. There is no decimal point after the 00, indicating that this is the high byte.
5. Press the [Data] key again to view the low byte.
6. Press the [View] key to display the next counter.
7. Press the [View] and [Data] keys together to clear all the counters.

Reading 1770-KFC15 Counters With a Diagnostic Command

Diagnostic counters can be read by sending a PCCC Diagnostic Read Counters command to the 1770-KFC15 module. See page C-2. The only change for firmware version 4.2 is that the new set of counters listed in Table C.6 on page C-4 can now be read by setting the address parameter to 0x0001. If the address parameter is set to any other value, the old 1770-KFC15 counters will be read instead.

Note that the PCCC diagnostic command can be sent from DF1 or ControlNet. On ControlNet, the command should be sent to the PCCC object.

Understanding the Extra-hop Feature

The extra-hop feature has been added so that network routing information can be added to standard PCCC, DF1 packets. For example, using this feature, a PCCC message from a PLC-5 message instruction can be routed through a 1770-KFC15 module to a 1756-CNB module, out the ControlLogix backplane port of the 1756-CNB module, and across the ControlLogix backplane to a Logix controller.

TIP

A hop is the route a message takes to get from one module to the next, via a single network segment. Network routing paths are constructed of one or more hops.

Before you send a PCCC read or write command to a Logix controller, you need to map one or more of the Logix controllers tags to a PLC- or SLC-style file number. To map a tag in RSLogix 5000:

1. Ensure RSLogix 5000 is offline.
2. Select the Logic menu.
3. Select Map PLC/SLC Messages.
4. Map one or more tags to file numbers.
5. Download the new configuration to the Logix controller.

There are two ways to use the extra-hop feature:

- Method 1: No Configuration
- Method 2: Configure a Path Using the Pushbuttons and 7-segment Display

Method 1: No Configuration

This is specifically intended to route messages through CNB modules to Logix controllers in the same backplane. Just add 100, 150, or 200 to the ControlNet node address of the DF1 message. (In full-duplex mode, the ControlNet node address of the DF1 message is simply the DF1 destination address which is ignored on the local DF1 link. In-half duplex mode, it is the remote address.)

When the new KFC sees an address that is higher than 99, it will add a Port Number of 1 and a Slot/Address of 0, 1 or 2 to the message. The Port Number of 1 refers to the ControlLogix backplane port of the CNB module.

- Adding 100 to the ControlNet node address will route the message to slot 0.
- Adding 150 to the ControlNet node address will route the message to slot 1.
- Adding 200 to the ControlNet node address will route the message to slot 2.

IMPORTANT

The actual ControlNet address of the CNB must be between 1 and 50.

EXAMPLE

You have a Logix rack with a controller in slot 0. The rack also contains a CNB that is set to Mac ID 5. You set up a PLC-5 (or other DF1 device) to send a message to address 105 (decimal). The message will get routed to the CNB at Mac ID 5 and then to the controller in slot 0.

Method 2: Configure a Path Using the Pushbuttons and 7-segment Display

TIP

This method works only for the 1770-KFC15 module.
For the 1747-KFC15 module, use method 1.

You can use this method to access Logix controllers that are in slots greater than 2. As many as 99 paths can be defined, with as many as 3 hops each. The ControlNet node address parameter is used to select which of the 99 paths is being defined or viewed. Therefore, you can define only one path for each ControlNet node address on the local ControlNet network.

A path consists of a path length followed by a sequence of port numbers and network addresses or slot numbers.

Path Length

The path length can be set to 0, 2, 4, or 6.

- 0 – Indicates that no path is configured.
- 2 – The path contains 1 hop (1 Port and 1 Address/Slot Number).
- 4 – The path contains 2 hops.
- 6 – The path contains 3 hops.

Port Numbers

Port numbers can range from 1 to 14. If a device has a backplane connector, that connector will be port 1.

See Table 5.1 on page 5-4 for the port numbers for several modules. Check the product documentation or EDS file to find the port numbers of other modules.

Table 5.1 Port numbers

Module:	Port Number:	Description
1756-CNB 1756-CNBR	Port 1	ControlLogix Backplane
	Port 2	ControlNet
1788-CN2DN	Port 2	DeviceNet
	Port 3	ControlNet
1770-KFC15 1747-KFC15	Port 2	ControlNet
	Port 3	DF1

Address/Slot Number

This is either the address of a node on a network or a slot number of a module in a backplane. The value has a range of 0 through 99. On the ControlLogix backplane, you can use slot numbers of 0 through 16.

Example 5.1

EXAMPLE

This example assumes a 1756-CNB at ControlNet node address 54 and a Logix controller (LGX) in slot 12 of a ControlLogix backplane. The slot number of the 1756-CNB, as well as the ControlNet node address of the 1770-KFC15, are not specified, since they are not needed to construct the path.

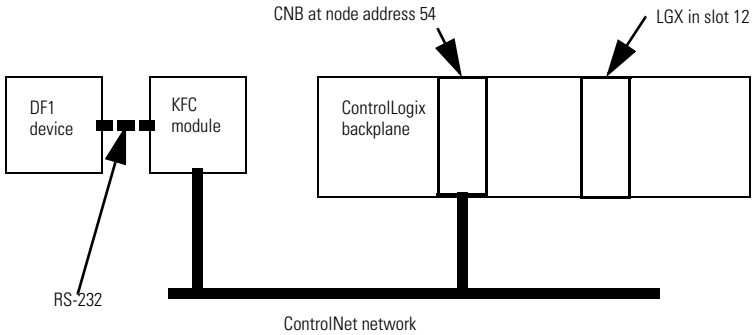

To program the path:

1. Press the [View] key several times until the path sub-menu appears. You see {P - -}.
2. Press [Data] to enter the path sub-menu.
3. Press [Data] to select the address of the ControlNet device (e.g., the CNB). If the address is 54, you see {- . 5 4}. The leading - indicates that no path has been defined for this ControlNet node address. That is, the path length is 0. If the path length is non-zero, you will see an A instead of the -; for example, {A. 5 4}. The A stands for Address or Active.
4. Press [View] to advance to the Path Length parameter. You see {L. 0 0}
5. Press [Data] to set the Path Length. Our example has 1 hop, so the path length will be 2, since 2 bytes are needed (one for Port and one for Slot/Address). You see {L. 0 2}.

6. Press [View] to advance to the first Port parameter. You see {1. 0 1}. The default Port Number is 1, so you don't need to do anything. Port 1 is the ControlLogix backplane port of the CNB module.
7. Press [View] to advance to the first Address/Slot parameter. You see {2. 0 0}
8. Press [Data] to set the Slot number. Since the controller is in slot 12, you see {2. 1 2}.

The Extra-hop path is now configured. Press [View] several times to review the path data. You see:

{A. 5 4}	The ControlNet node address parameter (the CNB ControlNet node address)
{L. 0 2}	The Path Length
{1. 0 1}	The first port. (1 => CNB ControlLogix backplane port).
{2. 1 2}	The first Address/Slot number (12 => Slot number of the Logix Controller).
{3. 0 1}	The second port. Not used in our example.
{4. 0 0}	The second Address/Slot number. Not used.
{5. 0 1}	The third port. Not used in our example.
{6. 0 0}	The third Address/Slot number. Not used.

TIP

Note that since the path length is 2, parameters 3, 4, 5 and 6 are ignored in this example. Also note that the Port Numbers default to 1, while the Address/Slot values default to 0.

9. You can now press [View] and [Exit] together to save the path to flash.

IMPORTANT

If you press [Exit] twice, the KFC will exit configuration mode and any information you entered will be discarded.

TIP

Note that up to 99 paths can be defined, with up to 3 hops each. The ControlNet node address parameter is used to select which of the 99 paths is being defined or viewed. Therefore, you can only define one path for each ControlNet node address on the local ControlNet network.

Example 5.2**EXAMPLE**

For this example you have 2 ControlNet networks. (See the diagram that follows). The first contains the 1770-KFC15 and a 1756-CNB. The 1756-CNB is at ControlNet node address 65. This is CNB 1. CNB 1 is in slot 4 of ControlLogix backplane 1.

The second network contains 2 1756-CNB modules. One CNB is at ControlNet node address 1 (CNB 2) and the other is at ControlNet node address 53 (CNB 3). CNB 2 is in slot 7 of ControlLogix backplane 1. CNB 3 is in ControlLogix backplane 2 along with a Logix Controller (LGX) in slot 16.

Note that neither the slot numbers of CNB 1 and CNB3 nor the node address of CNB 2 are needed to construct the path.

The following path will route a DF1 message from the DF1 device to the Logix Controller in slot 16 of the remote ControlLogix backplane. The DF1 message should be sent to address 65.

Figure 5.1

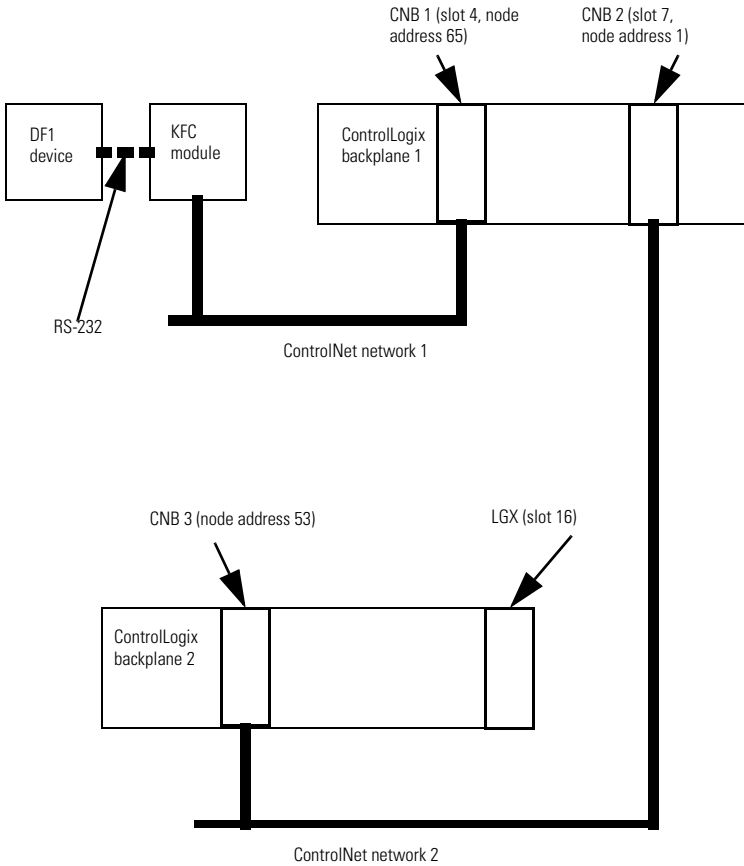

You see:

{A. 6 5}	The ControlNet node address parameter (node address of CNB 1)
{L. 0 6}	The Path Length (6 => 3 hops)
{1. 0 1}	The 1st port. (1 => ControlLogix Backplane port of CNB 1)
{2. 0 7}	The 1st Address/Slot Number. (7 => Slot # of CNB 2)
{3. 0 2}	The 2nd port. (2 => ControlNet port of CNB 2)
{4. 5 3}	The 2nd Address/Slot Number. (53 => The ControlNet node address of CNB 3)
{5. 0 1}	The 3rd port. (1 => ControlLogix Backplane port of CNB 3).
{6. 1 6}	The 3rd Address/Slot Number. (16 => Slot # of Logix Controller.)

Communicating with the Module

DF1 Communication

The module supports both full-duplex and half-duplex DF1 protocol between it and a host device. This protocol can be used over either the serial or parallel interface to send PCCC or ControlNet messages across the ControlNet cable system to other nodes. For more information on PCCC messages refer to the DF1 Protocol and Command Set Reference Manual, 1770-RM516.

The host device must send messages in a form that the end node it is communicating with understands. The module does not translate between two types of messages. If the end node only recognizes one type, the host device's communication driver must send the same form.

Serial Communication

Serial communication with the module can be either full- or half-duplex DF1. The duplex used depends on the overall application's requirements.

Full-duplex serial protocol:

- is a direct link that allows simultaneous two-way transmission
- often requires a system programmer to use interrupts and multi-tasking techniques
- is intended for high-performance applications where maximum data throughput is necessary
- gives faster data throughput than half duplex, but is more difficult to expand or to use when communicating with more than one 1770-KFC15 module
- Since it is faster and easier to configure, full-duplex mode is always recommended

Figure 6.1 Full-duplex Serial Protocol

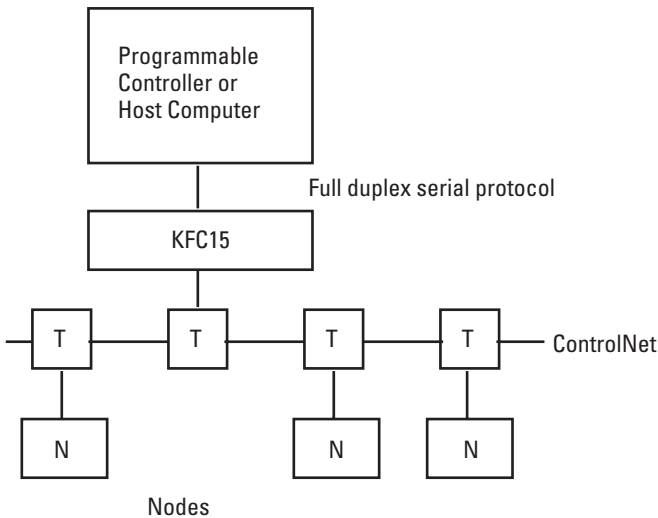

31362-M

Half-duplex serial protocol:

- is a protocol for one host processor and one or more field devices.
You must use half-duplex modems if there is more than one 1770-KFC15 module.
- allows only one host processor or field device to transmit at any one time
- provides a less effective usage of resources than full duplex; may be easier to implement, but it is more difficult to configure

Half-duplex protocol can be used on a point-to-point link, but more commonly it operates on a link with all nodes interfaced through half-duplex modems. There can be from 0 to 63 decimal nodes simultaneously connected to a single link.

With half-duplex protocol, you can use a:

two-circuit system— the master sends and slaves receive on one circuit, slaves send and master receives on the other

one-circuit system— master and slaves send and receive on the same circuit

Figure 6.2 Half-duplex Multi-drop Serial Network

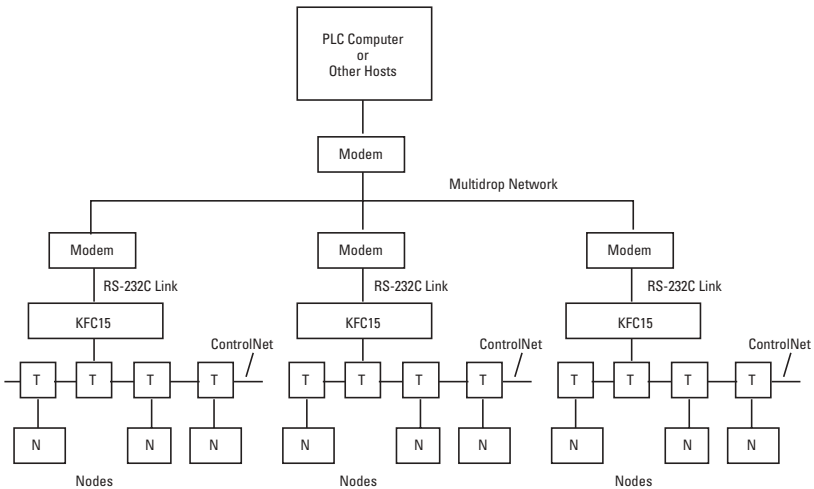

3183-M

Parallel Communication

Parallel communication with the module can be half-duplex DF1 only. Full duplex is not supported. The parallel port is not supported in V4.2 or later.

Half-duplex parallel protocol:

- uses the same protocol as with half-duplex RS-232C (serial)
- must be point-to-point (cannot be multidrop)

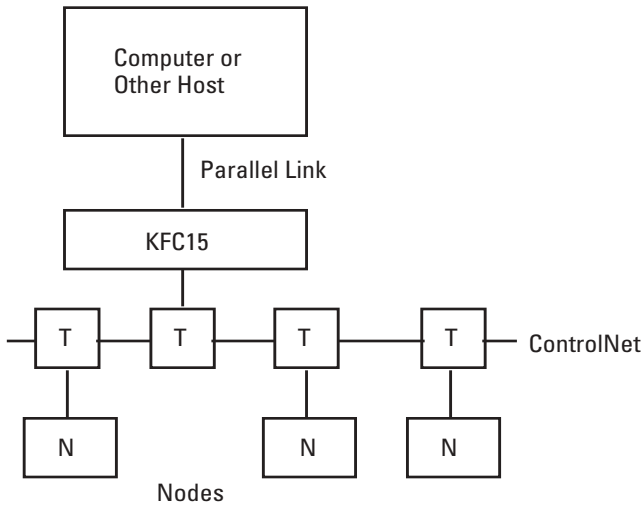

31364-M

With parallel half-duplex communication, a host device can send eight bits of the DF1 message at a time to the module. The host device can receive four bits of a message at a time from the module in NIBBLE MODE. In instances where the host device has a bidirectional parallel port, it can receive messages eight bits (one byte) at a time in BYTE MODE. See chapter 4, Configuring the Module, for instructions on setting the operating mode.

If you plan to use parallel port communication and your application requires that you write your own driver, see appendix D, Writing a Parallel Communication Driver, for details.

Embedded Responses

An embedded response occurs when a DF1 ACK or NAK is embedded within another DF1 message. Embedded responses can improve the throughput of a full-duplex DF1 link since a transmitter will not need to wait any longer than necessary to receive a response (ACK or NAK) to the last message it has sent. The old KFC would always send an embedded response whenever there was an opportunity to do so. However, some DF1 drivers can not tolerate them. Therefore, the new KFC (V4.2 and newer) can be configured to send or not send embedded responses.

By default, the 1770-KFC15 will wait until it hears an embedded response before sending one. This is referred to as embedded-response “auto-detect” mode.

NOTE: This is the only embedded-response mode available on the 1747-KFC15.

The 1770-KFC15 defaults to embedded response “auto-detect” mode but can also be configured to always send or never send embedded responses. Parameter 6 in the ‘A’ sub-menu is used to configure the embedded response mode. The parameter can have one of the following values:

- 0 – Auto Detect – Default
- 1 – Always send embedded responses
- 2 – Never send embedded responses

To configure this parameter, do the following:

1. Press the [View] key several times until the ‘A’ sub-menu appears. You see {A - -}
2. Press the [Data] key to enter the sub-menu.
3. You see {0. 0 2} assuming the number of DF1 retries is set to 2.
4. Press the [View] key several times until parameter 6 appears. You see {6 0 0}, indicating that Auto-Detect mode is active.
5. Press the [Data] key to change the value.
6. Press the [View] and [Exit] keys together to save the new value.

For more information on configuring 1770-KFC15 parameters, refer to chapter 4.

Message Reply Time-out

To aid in memory buffer management, a message reply time-out parameter has been added to the V4.2 and later 1770-KFC15 firmware. This is the length of time the KFC will wait for a reply to a request message. Note that this is different than an ACK time-out, which occurs if the network node to which the message was sent cannot respond. The message reply time-out becomes active only after an ACK is received.

If the request message was sent on ControlNet and no reply message is received before the timer expires, an error reply with the status byte set to 2 (2 means undeliverable) is sent on DF1 and the memory buffers are freed up to handle new messages.

If the request message was sent on DF1 and no message is received before the timer expires, no error reply is sent on ControlNet. However, the memory buffers are freed up to handle new messages. It is assumed that the node that originated the original request message on ControlNet has already timed out and does not need a reply.

For the 1770-KFC15, parameter 7 in the 'A' sub-menu is used to configure the message reply time-out. This parameter represents time in seconds and has a range of 1 to 99 seconds. The default value is 5 seconds. For instructions on how to program a parameter in the 'A' sub-menu, refer to chapter 4.

NOTE: For the 1747-KFC15, the message reply time-out is set to 10 times the DF1 ACK time-out. The default value is 32 seconds since the default DF1 ACK time-out value is 3.2 seconds.

TIP

In a normally functioning system, the message reply timeout should never occur, since it would be rare for a device to acknowledge a message with an ACK and then never send a reply.

Default DF1 Address

When a standard (non-DH+) PCCC message is received from ControlNet, the KFC must decide to which destination address to send it on the DF1 link. The old KFC would always send such packets with a DF1 destination address equal to the ControlNet address of the KFC. This means that if you are using half-duplex mode, the address of the other DF1 device must be set to the ControlNet address of the KFC. For the new 1770-KFC15, the default DF1 destination address can be configured so that the DF1 address of the other device does not have to match the ControlNet address of the KFC.

For the 1770-KFC15, parameter 8 in the 'A' sub-menu is used to configure the default DF1 address. This parameter is a hexadecimal value and has a range of 0 to FF. The value FE is a special value that indicates that the current ControlNet address should be used. The default value is FE. Therefore, the default behavior is to use the ControlNet address just as the old KFC did. For instructions on how to program a parameter in the 'A' sub-menu, refer to chapter 4.

NOTE: The new 1747-KFC15 will always use the ControlNet address as the default DF1 destination address as did the old KFC.

Note that DH+ PCCC messages (i.e., PCCC messages that originate from a device on DH+) have source and destination information contained in their message header. Therefore, these source and destination values are used for the source and destination addresses on the DF1 link.

DF1 SRC and DST Address

In full-duplex mode, the SRC and DST values are ignored on the DF1 link. This is because full-duplex operation implies a point-to-point configuration with only two nodes on the DF1 link. Since there are only two nodes, there is no need to examine the SRC and DST values. In fact, you will often see the SRC and DST addresses set to the same value on a full-duplex DF1 network.

In half-duplex mode, more than two nodes are allowed to be connected to the DF1 network (if half-duplex modems are used). The SRC and DST address values are used to determine which node is to receive which packet. For example, in half-duplex mode, the KFC will not receive any DF1 messages unless the DST address is equal to its DF1 station address.

DF1 SRC (source) and DST (destination) values are chosen in the following 3 cases:

1. If the message request came in from the DF1 port, the DF1 reply message will have SRC and DST address values that are opposite that of the request message. For example:
 - Reply DST = Request SRC
 - Reply SRC = Request DST

This is compliant with the DF1 specification. Note that the old KFC would always set the DST address to its ControlNet address.

2. If a standard PCCC message request comes in from ControlNet, it must be forwarded onto the DF1 link. The DF1 request message will have a DST address equal to the default DF1 destination address (usually set to the KFC's ControlNet address). The DF1 SRC address will be equal to the ControlNet address of the node that sent the message (the ControlNet source address) if the serial port is operating in full-duplex mode. In half-duplex mode, the DF1 SRC address is always set to the KFC's DF1 station address.
 - Request DST = default DF1 destination address (Refer to Default DF1 Address on page 6.)
 - Request SRC = ControlNet source address (full-duplex mode) or the KFC's DF1 station address (half-duplex mode).

3. If a DH+ PCCC message request comes in from ControlNet, it must be forwarded onto the DF1 link. Since DH+ PCCC messages have source and destination information contained in their message header, these source and destination values can be used for the SRC and DST addresses on the DF1 link. However, note that in half-duplex mode, the DF1 SRC address is always set to the KFC's DF1 station address.
 - Request DST = Destination address from message header
 - Request SRC = Source address from message header (full-duplex mode) or the KFC's DF1 station address (half-duplex mode).

TIP

Since it is easier to configure and much faster to run, full-duplex mode is always the preferred mode of operation. Use half-duplex mode only if you do not have a choice.

RSLinx DF1 Driver Anomaly

In versions of RSLinx older than 2.31.00, the DF1 driver has a rare anomaly which causes the driver to cease to transmit packets. If the driver is in this state and you examine the RSLinx driver diagnostics for the DF1 driver, you will see the Write Errors counter incrementing as the driver attempts to send packets.

To recover from this condition, either stop and start the driver in RSLinx or delete it and configure it again.

Auto-recovery

An auto-recovery feature has been added so that the new KFC can automatically recover from non-hardware error conditions. The default setting for this feature is “Disabled.” It is recommended that this feature be enabled if the KFC is operating in a remote location where a manual reset of the module would be difficult. Using the KFC to connect to a remote location using phone modems is one example.

One example of a non-hardware error condition that could trigger this feature would be that the KFC ran out of memory buffers and was unable to recover from this condition within 35 seconds.

For the 1770-KFC15, parameter 9 in the ‘A’ sub-menu is used to configure the auto-recovery feature. A parameter value of 0 means disabled (the default), and a value of 1 means enabled. For instructions on how to program a parameter in the ‘A’ sub-menu, refer to chapter 4.

NOTE: For the 1747-KFC15, switch 7 of DIP switch bank S1 is used to configure the auto-recovery feature. Off means disabled (the default), and on means enabled.

Message Buffers

The new 1770-KFC15 has 18 message buffers. However, if the messages are PCCC messages coming in from ControlNet, the number is limited to 10 outstanding messages.

From an application point of view, this means that a DF1 device (PLC-5, DCS, RSLinx, etc.) connected to the serial port of a new 1770-KFC15 is able to send 18 DF1 messages through the KFC before receiving a reply to any of them. This is referred to as 18 outstanding messages. If a 19th message is sent by the DF1 device before a reply, good or bad, is returned for any of the 18 other messages, the KFC will respond with a NAK to indicate that it is low on memory and does not have a message buffer in which to place the 19th message. If this happens, the DF1 device should wait until it hears a reply to one of the outstanding messages (or until the message times out) and try the 19th message again.

In general, applications using the 1770-KFC15 should be designed so that no more than 18 DF1 messages are outstanding at one time. For example, a PLC-5 connected to the serial port of the 1770-KFC15, should not be programmed to execute more than 18 message instructions at one time that would send DF1 messages to the KFC's serial port.

NOTE: The new 1747-KFC15 has 67 message buffers. If a 1747-KFC15 is used, then 67 DF1 message instructions can be executed simultaneously.

The picture is different for applications that send PCCC messages to the KFC via ControlNet. For example, consider an application that has 3 PLC-5 processors and a KFC all connected to ControlNet. The KFC has some DF1 device connected to its serial port. The PLC-5 processors have been programmed with message instructions that read data from the DF1 device via ControlNet and the KFC. This application should be designed so that no more than 10 message instructions execute at one time in all 3 of the PLC-5 processors.

For applications using the RSLinx DF1 driver, a user trying to increase the number of outstanding messages the RSLinx driver uses (to browse the ControlNet network, for example), should use care when doing so. Some messages may time out too soon. If this happens, the user sees red X's in the RSWho screen. If the number of outstanding messages is increased from 3 to 10, for example, the time-outs should also be increased to a value near 10 seconds (depending on the network configuration).

TIP

We recommend using the RSLinx DF1 default driver settings of 3 outstanding messages with a 3-second time-out.

Troubleshooting the Module

Use this chapter to interpret the indicators (status LEDs and seven-segment LED displays) on the module to help you troubleshoot problems.

Interpreting the Status LEDs

There are four, bi-color (red/green) status LEDs on the top of the module. Two are for ControlNet showing physical layer status of channels A (primary connection) and B (redundant media connection), one is for communication on the RS-232C or parallel port (HOST), and one is for the module (STATUS). These indicators can help you diagnose problems with the module's installation and operation.

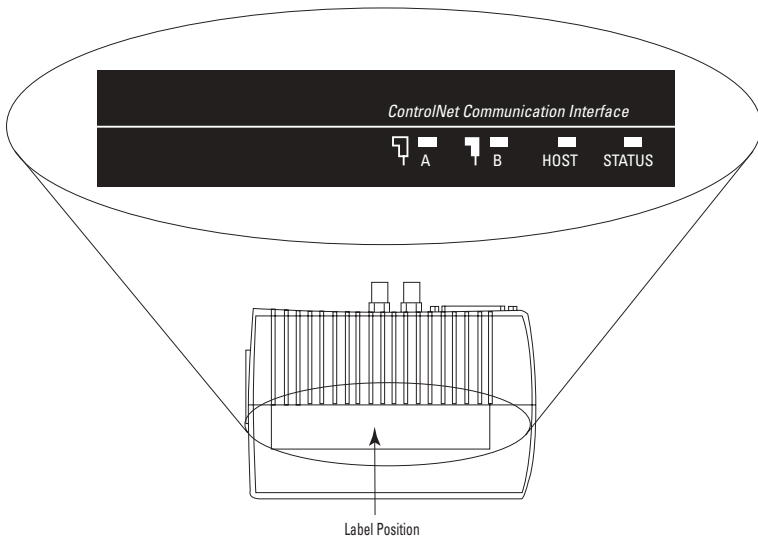

31385-M

Term	State of the LED
solid	on continuously in the defined state
flashing	each LED alternates between the two defined states (or with OFF if only one state is defined). This only applies to a single LED viewed independently of the other. If both ControlNet LEDs are flashing, they flash together (in phase)
railroad	both LEDs alternate between the two defined states at the same time. This only applies to both ControlNet LEDs when viewed together. The two LEDs are always in opposite states (out-of-phase)
flickering	intermittent on/off between the two states, often in an erratic pattern

LED	State	Probable Cause	Recommended Action
Channels A and B (viewed together)	OFF	No power or reset	
	SOLID RED	Failed unit	Check network setup then cycle power to the module. If the fault persists, contact your authorized Allen-Bradley representative or distributor.
	RAILROAD RED-GREEN	Self test	None
	RAILROAD RED-OFF	Incorrect node configuration (duplicate node, ID, etc.)	Check network address and other ControlNet configuration parameters.
Channel A and B (viewed separately)	OFF	Channel disabled or unused	Program network for redundant media, if required.
	SOLID GREEN	Channel good--data is being received and transmitted on this channel	None
	FLASHING GREEN-OFF	Temporary errors or device is not online	None. Unit will correct itself.
	FLASHING RED-GREEN	Bad network configuration	Check network setup then cycle power to the module.
	FLASHING RED-OFF	Media fault or no other nodes present on the network	Check media for broken cables, loose connectors, missing terminators, etc.

LED	State	Probable Cause	Recommended Action
HOST	OFF	No activity or no host present	None
	FLICKERING GREEN-OFF	Link OK--data is being transmitted or received over the RS-232C or parallel port	None
	SOLID RED	Link fault--the module has detected a communication fault	Check cable pinouts and parameter settings, then reset the module. If the fault persists, contact your authorized Allen-Bradley representative or distributor.
	FLASHING RED	Not defined	None
STATUS	OFF	No power is applied to the module	None
	SOLID GREEN	Normal operation--the module is okay	None
	FLASHING GREEN	The module is not properly configured	Check and change parameter settings.
	SOLID RED	Critical fault--the module has detected an unrecoverable fault	Check the seven-segment display to see if an error code or error message is being displayed. Contact your Allen-Bradley representative with this error information. Try resetting the module. If the fault is not a hardware problem, the module will recover.
	FLASHING RED	Non-critical fault--the module has detected a recoverable fault	Reconfigure and/or reset the module.

Interpreting the Seven-Segment LED Displays

Under normal conditions, the numeric displays should be off unless you are configuring the communication parameters. During operation, the numeric displays are used to indicate hardware fault conditions. When the STATUS LED is solid or flashing red, the left parameter display will show a number indicating the type of hardware fault. Table 7.1 gives a description of the faults.

Table 7.1 Fault Descriptions

This number:	Indicates this fault:	Meaning:
1	Processor Fault	A hardware fault was detected in the processor. This is a major fault. Return the module for servicing.
2	Invalid Firmware	The Flash EPROM does not contain valid firmware. New firmware must be downloaded to the unit.
3	RAM Fault	The static RAM cannot be written to reliably or a parity error has occurred. Cycle power to the module. If the problem persists, return the module for servicing.
4	Stuck Button Detected	One or more pushbuttons are stuck on. This could be caused by a mechanical problem with the buttons, or by an object pressing on the pushbuttons. If the cause is mechanical, the module should be returned for servicing. Otherwise, remove the pressure from the pushbuttons to clear the fault condition. The module will continue to communicate when this fault is detected, but configuration will not be possible.
5	Flash EPROM Write Fault	The Flash EPROM could not be programmed correctly during download of new firmware. This is a major fault. Return the module for servicing.
6	Flash EPROM Major Fault	The module was unable to write the new configuration to the Flash EPROM. This is a major fault. Return the module for servicing.
7	Flash EPROM Minor Fault	On power up, the module detected invalid configuration data in the Flash EPROM. The module recovered by writing the factory default configuration to the Flash EPROM. You must power the module off and back on, and then reconfigure it. This is not a major fault, but if the problem persists, return the module for servicing.

Table 7.1 Fault Descriptions

This number:	Indicates this fault:	Meaning:
8	Power Failure	The power supply voltage is below the minimum rating for the module. The module will continue to communicate when this fault is detected, but configuration will not be possible.
9	Invalid Network Address	The chosen network address is greater than the highest network address ControlNet is configured for.
A	Duplicate Network Address	There is a device on the ControlNet network with the same address.
B	Unrecoverable Firmware Error	Failed to reprogram the boot block of the Flash EPROM. Return the module for servicing.

If the displays show symbols other than those shown in this chapter or in a scrolling message, this also indicates that the module is malfunctioning. In this case, contact your Allen-Bradley representative.

In addition to the above fault codes, V4.2 and later will display a scrolling message when a non-hardware fault is detected. The scrolling error message will have this format:

Err-<error number> <file name> L-<line number> T-<task ID>

The values in angle brackets <> will be replaced by actual numbers or letters in a real error message, for example:

Err-0302 CI_UTIL.C L-453 T-12

See Table 7.2 on page 7-6 for possible file names.

Table 7.2 Possible File Names

AB_INIT.C	CM_ORIG.C	DI_CFG70.C	LL_UTIL.C	P3U_OBJ.C
AB_STAT.C	CM_TARGET.C	DI_COMON.C	MAIN.C	SM_CD.C
ABU_INIT.C	CN_OBJ.C	FM_UTIL.C	MR_ROUTR.C	SM_CN.C
AD_UTIL.C	DB_OBJ.C	GO_OBJ.C	NV_OBJ.C	SM_ISR.C
BD_UTIL.C	DF_CD.C	GS_EVENT.C	NVS_CNET.C	SM_UTIL.C
BR_OBJ.C	DF_SPOBJ.C	GS_UTIL.C	NVS_DF1.C	SM_XPORT.C
BU_BITS.C	DF_UM.C	ID_OBJ.C	OS_KERN.C	SMU_HW.C
CB_UTIL.C	DF_UTIL.C	KFC_HW.C	OS_NULL.C	UC_UTIL.C
CD_UTIL.C	DFU_HW.C	KP_OBJ.C	P3_FRAG.C	UM_UTIL.C
CI_UTIL.C	DI_1770.C	KP_STUB.C	P3_OBJ.C	

Product Specifications

RS-232C Interface	
Start Bits	1
Data Bits	8
Parity	None, Even, Odd
Stop Bits	1
Baud Rates	300, 600, 1200, 2400, 4800, 9600, 19200, 38400
Connector	DB-25P (male) with 4-40 screwlock hardware
Output	RS-232C
Protocol	Allen-Bradley DF1
Cable Length	Recommended maximum of 7.5 m (25 ft) at 38400 baud, or 15 m (50 ft) at lower baud rates
Cable Type	Shielded
Isolation Voltage	Not isolated
Parallel Port Interface	
Connector	DB-25 (female) with 4-40 screwlock hardware
Data Format	DF1 Nibble or DF1 Byte transfers with handshaking
Cable Length	Recommended maximum of 3 m (10 ft)
Cable Type	Shielded
Isolation Voltage	Not isolated
ControlNet Interface	
Connectors	Standard BNC connectors
Cable	RG-6 75-ohm coaxial cable
Media Redundancy	Connection for 2 independent coaxial cables
Isolation Voltage	50V - transformer, isolated
Network Access Port (NAP) Interface	
Connector	RJ-45 8-pin, phone jack with shield
Isolation Voltage	50V, Opto-isolated

A-2 Product Specifications

RS-232C Interface	
Operating Temperature	IEC 60068-2-1 (Test Ad, Operating Cold), IEC 60068-2-2 (Test Bd, Operating Dry Heat), IEC 60068-2-14 (Test Nb, Operating Thermal Shock): 0 to 60°C (32 to 140°F)
Storage Temperature	IEC 60068-2-1 (Test Ab, Un-packaged Non-operating Cold), IEC 60068-2-2 (Test Bb, Un-packaged Non-operating Dry Heat), IEC 60068-2-14 (Test Na, Un-packaged Non-operating Thermal Shock): -40 to 85°C (-40 to 185°F)
Relative Humidity	IEC 60068-2-30 (Test Db, Un-packaged Non-operating Damp Heat): 5 to 95% non-condensing
Dimensions	11.7 cm x 17.8 cm by 5.1 cm (4.6 in x 7 in x 2 in)
Weight	0.9 kg (2 lb)
Mounting	Table top or wall/bracket mounted
Emissions	CISPR 11: Group 1, Class A
Radiated RF Immunity	IEC 61000-4-3: 10V/m with 1kHz sine-wave 80%AM from 30MHz to 1000MHz 10V/m with 200Hz 50% Pulse 100%AM at 900Mhz
Surge Transient Immunity	IEC 61000-4-5:
AC Power Lines	±1kV line-line(DM) and ±2kV line-earth(CM) on AC power ports
Communication Lines	±2kV line-earth(CM) on shielded ports
ESD Immunity	IEC 61000-4-2: 4kV contact discharges 8kV air discharges
EFT/B Immunity	IEC 61000-4-4: ±2kV at 5kHz on power ports ±2kV at 5kHz on communications ports
Conducted RF Immunity	IEC 61000-4-6: 10Vrms with 1kHz sine-wave 80%AM from 150kHz to 30MHz
Enclosure Type Rating	Nema IP20 Type 1 - for indoor counter-top use only
Vibration	IEC60068-2-6 (Test Fc, Operating): 1g @ 10-150Hz
Shock	IEC60068-2-27 (Test Ea, Unpackaged Shock): Operating 30g Non-operating 50g

	1770-KFC15
Supply Rating	115/230V ac 50/60 Hz, 0.2/0.1A
Power Dissipation	23W
Cord	Hard Service S or Junior Hard Service SJ grade 14AWG, 250V rating 115 Volt operation: Alpha Wire #546 230 Volt operation: Alpha Wire #920
Branch Circuit Protection	10A
Fuse	5 x 20 mm, 0.5A, 250V, IEC 127 Type T (Blue) Bussmann GDC-500mA Littelfuse 218.500
Wire Temperature Rating	60 C
Wire Category	1 - AC mains ⁽¹⁾ 2 - all other communication ports ⁽¹⁾
Isolation Voltage	250V reinforced insulation between AC mains supply and user accessible communication ports
Certifications (when product is marked)	UL - UL Listed Industrial Control Equipment CSA - CSA Certified Process Control Equipment CE ⁽²⁾ - European Union 89/336/EEC EMC Directive, compliant with: EN 50082-2; Industrial Immunity EN 61326; Meas./Control/Lab., Industrial Requirements EN 61000-6-2; Industrial Immunity EN 61000-6-4; Industrial Emissions European Union 73/23/EEC LVD Directive, compliant with: EN 61131-2; Programmable Controllers C-Tick ⁽²⁾ - Australian Radiocommunications Act, compliant with: AS/NZS CISPR11; Industrial Emissions

⁽¹⁾ Use this conductor category information for planning conductor routing. Refer to publication 1770-4.1, 'Industrial Automation Wiring and Grounding Guidelines'.

⁽²⁾ See the Product Certification link at www.ab.com for Declarations of Conformity, Certificates, and other certification details.

Notes:

Cabling and Pinouts

This appendix contains the pinout and wiring information required if you need to construct cables before connecting the 1770-KFC15 module to a host device.

Cabling and Pinouts for RS-232C Connection

The 1770-KFC15 module's RS-232C connector is a DB-25 male with the following EIA standard pinout:

Table B.1 EIA Standard Pinout

	Signal	I/O	Pin
GND	Chassis ground	-	1
TXD	Transmitted data	0	2
RXD	Received data	1	3
RTS	Request to send	0	4
CTS	Clear to send	1	5
DSR	Data set ready	1	6
COM	Signal common	-	7
DCD	Data carrier detect	1	8
DTR	Data terminal ready	0	20

The following diagrams illustrate wiring for a three-wire cable and a cable with handshaking lines. The maximum recommended cable lengths are:

- baud rates less than or equal to 19200 15 m (50 ft)
- baud rates equal to 38400 7.5 m (25 ft)

Figure B.1 Three Wire Connections to IBM Computers (25-pin)

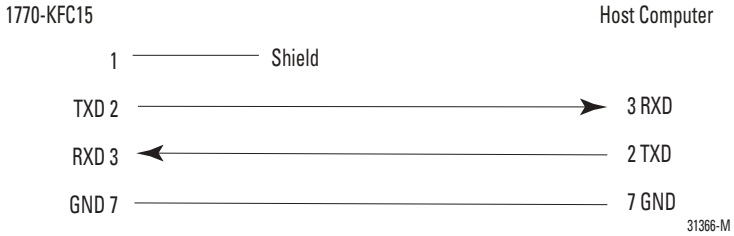
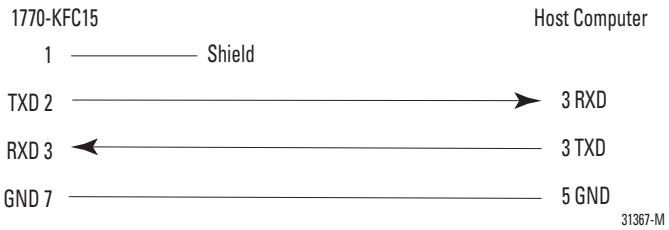
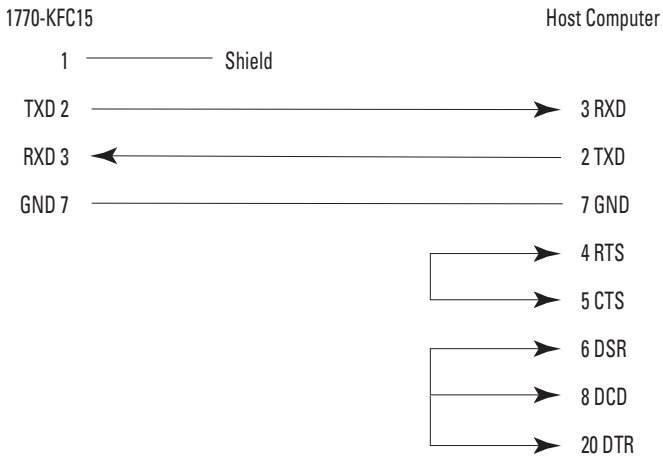

Figure B.2 Three Wire Connections to IBM Computers (9-pin)



If you require active DSR and CTS signals and you don't require handshaking lines from the module, add jumpers to the computer connections as shown in the next two illustrations.

Figure B.3 Jumper Positions for DSR and CTS Lines (25-pin)



31368-M

Figure B.4 Jumper Positions for DSR and CTS Lines (9-pin)

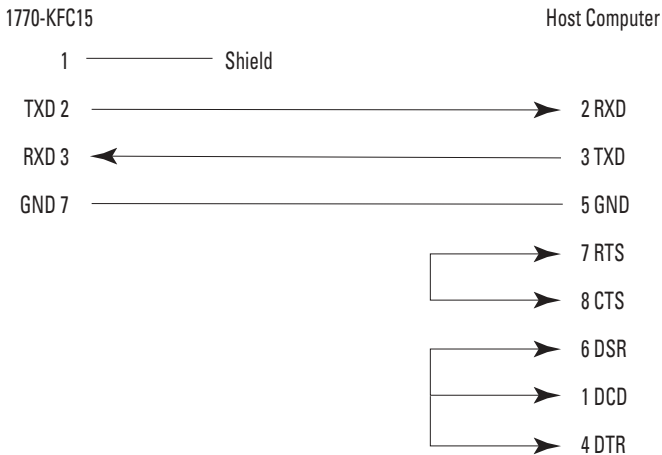

31369-M

If you are using handshake signals with your computer, use pinouts as shown in the next two illustrations.

Figure B.5 Connection to IBM Computer with Handshake Signals (25-pin)

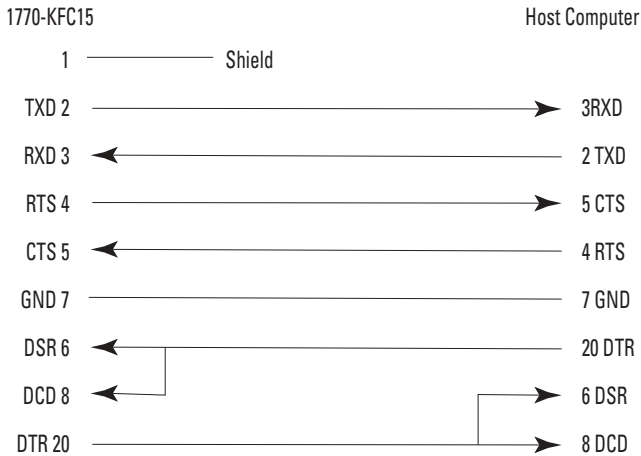

31371-M

Figure B.6 Connection to IBM Computer with Handshake Signals (9-pin)

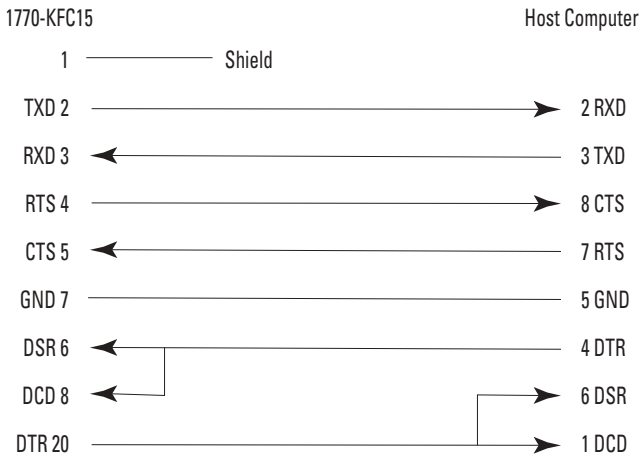

31371-M

The 1770-KFC15 module is connected to a modem through the RS-232C serial port.

Figure B.7 Connection between the 1770-KFC15 and a Modem

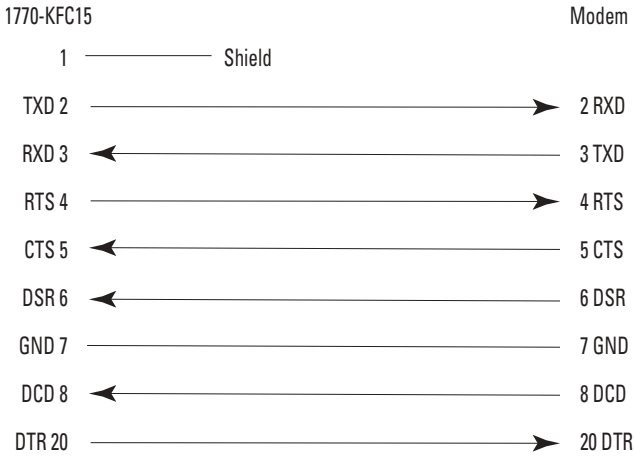

31372-M

Cabling and Pinouts for Parallel Port Connection

The parallel port interface connector is a DB-25 female with the Centronics standard pinout shown in the table below. The polarity in the fourth column applies when a signal is active. Negative polarity indicates an active low signal, while positive polarity indicates an active high signal.

Table B.2 Centronics Standard Pinout

Signal	I/O	Pin	Polarity
Strobe	I	1	-
Data 0	I/O	2	+
Data 1	I/O	3	+
Data 2	I/O	4	+
Data 3	I/O	5	+
Data 4	I/O	6	+
Data 5	I/O	7	+
Data 6	I/O	8	+
Data 7	I/O	9	+
Acknowledge	O	10	-
Busy	O	11	+
P. End	O	12	+
Select	O	13	+
Auto Feed	I	14	-
Error	O	15	-
Initialize Printer	I	16	-
Select Input	I	17	-
Ground	-	18-25	-

Figure B.8 illustrates the wiring for a cable to connect the 1770-KFC15 module to a host computer through the parallel port. You must use a shielded cable.

Figure B.8 Connection to IBM Computer through the Parallel Port (25-pin)

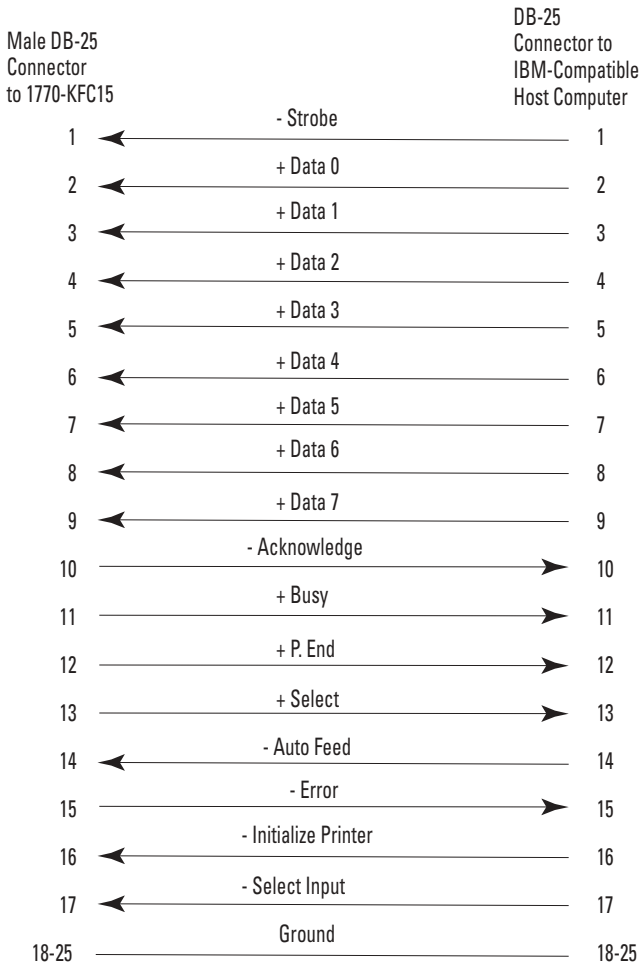

31373-M

Notes:

DF1 Diagnostic Command Support

The information in this appendix deals with DF1 communications between the host processor and 1770-KFC15 module. The module interprets and responds to the following diagnostic commands from the host:

Description	Command Byte	Function Code (hex)
Diagnostic Loop	06	00
Diagnostic Read Counters	06	01
Diagnostic Status	06	03
Reset Diagnostic Counters	06	07

In the Command and Reply Format tables, we report all values in hex and we use these abbreviations:

ADDR	address of data to be read
CMD	command code
FNC	function code
STS	status code
TNS	transaction number

Diagnostic Loop

You can use this command to check the integrity of the transmissions over the communication link. The command message transmits up to 243 bytes of data to a node interface module. The receiving module should reply to this command by transmitting the same data back to the originating node.

Table C.1 Command Format

1 byte	1 byte	2 bytes	1 byte	243 bytes max
CMD 06	STS	TNS	FNC 00	DATA

Table C.2 Reply Format

1 byte	1 byte	2 bytes	243 bytes max
CMD 46	STS	TNS	DATA

Diagnostic Read Counters

This command reads the diagnostic counters from the module. The format of these counters is given below.

For versions of firmware before V4.2, the address and size fields can have any value (but they must be included).

For V4.2 and later, if the address field is set to 0001, a new set of counters is returned. See Table C.6. Any other address value will cause the old counters to be returned.

Table C.3 Command Format

1 byte	1 byte	2 bytes	1 byte	2 bytes	1 byte
CMD 06	STS	TNS	FNC 01	ADDR 0000	SIZE 00

Table C.4 Reply Format

1 byte	1 byte	2 bytes	16 bytes (old counters) or 46 bytes (new counters)
CMD 46	STS	TNS	DATA

Table C.5 Reply Values (8-bit wide old counter descriptions)

Counter	Description
1	Total DF1 packets received, low byte
2	Total DF1 packets received, high byte
3	Total DF1 packets transmitted, low byte
4	Total DF1 packets transmitted, high byte
5	Number of DF1 retries
6	Number of DF1 packets where the retry limit was exceeded
7	Number of DF1 NAKs sent
8	Number of DF1 NAKs received
9	Number of DF1 bad messages received
10	Number of RS_232C line errors
11	Total good ControlNet packets received, low byte
12	Total good ControlNet packets received, high byte
13	Total bad ControlNet packets received, low byte
14	Total bad ControlNet packets received, high byte
15	Total ControlNet packets transmitted, low byte
16	Total ControlNet packets transmitted, high byte

Table C.6 Reply Values (16-bit wide new counter descriptions)

Counter (1)	Description
0	Handshake Lines (Low byte only). This is a hexadecimal value that indicates the state of the hardware handshake lines. The bits are defined as follows: x x x DTR DCD DSR RTS CTS. The three most significant bits, represented by 'x', are not used and are always 0. There is no corresponding upper byte for this counter.
1	DF1 packets transmitted
2	DF1 packets received
3	DF1 retries exceeded
4	DF1 retries
5	DF1 NAKs received
6	DF1 ENQs received. In Half-Duplex mode, these are POLL commands from the Half-Duplex master
7	DF1 NAKs sent for reasons other than low memory
8	DF1 NAKs sent due to low memory
9	DF1 Duplicate packets received
A	DF1 CRC or BCC errors
B	DF1 Unmatched Responses
C	DF1 Rx Overrun Errors
D	DF1 Rx Framing or Parity Errors
E	DF1 ENQs sent
F	PCCC status byte, STS, non-zero in Tx packet
G	PCCC status byte, STS, non-zero in Rx packet
H	Fragmentation Errors
I	DF1 Number of DLE STXs seen. If this counter is advancing but counter 2 is not, the DF1 address could be set incorrectly in Half-Duplex mode. The address is ignored in Full-Duplex mode.
J	Connection Timeouts
K	CNet Rx Good Packets
L	CNet Rx Bad Packets
M	CNet Tx Packets

(1) Counters are 16 bits so there is a total of 46 bytes of counter information in the Read Counter Reply packet.

These counters can also be displayed on the seven-segment display by accessing the counter sub-menu. See chapter 4.

Diagnostic Status

This command requests a block of status information from an RS-232C device. The reply contains the information in its DATA field. The status information varies from device to device. The status block is shown below.

Table C.7 Command Format

1 byte	1 byte	2 bytes	1 byte
CMD 06	STS	TNS	FNC 03

Table C.8 Reply Format

1 byte	1 byte	2 bytes	24 bytes max
CMD 46	STS	TNS	DATA

Table C.9 Reply Values

Data Byte	Description	Status Reply
1	Mode/Status Byte	00 (No Modes)
2	Interface/Processor Type Bits 0-3: Interface type (E = Extended) Bits 4-7: Processor type (F= Computer)	FE (Extended)
3	Extended Interface Type	5F
4	Online/Offline Mode	0 = online; 1 = offline
5	Series/Revision Bits 0-4: Revision Bits 5-7: Series	0 = Revision A 1 = Revision B, etc. 0 = Series A 1 = Series B, etc.
6 - 16	Bulletin Name = ASCII	"1770_KFC15 "
17 - 24	Reserved for factory use only	Values may vary

Diagnostic Counter Reset

This command resets the diagnostic counters listed above.

Table C.10 Command Format

1 byte	1 byte	2 bytes	1 byte
CMD 06	STS	TNS	FNC 07

Table C.11 Reply Format

1 byte	1 byte	2 bytes
CMD 46	STS	TNS

1747-KFC15 Meters

Instead of counters, the 1747-KFC15 module shows traffic activity and error conditions on 6 display-panel meters. The meters come in 2 groups of 3 and are to the right of the OK and address messages. For example, if the 1747-KFC module's ControlNet address is 30 and all the meters are at maximum value, you would see:

OK ||| |||

alternating with:

30 ||| |||

From left to right, the meters are:

1. DF1 Packets Sent
2. DF1 Packets Received
3. CNet Packets Received
4. DF1 NAKs Sent or Received
5. DF1 Line Errors (framing + parity + overrun)
6. DF1 PCCC status byte, STS, non-zero in Rx or Tx packet.

Since meters 4, 5, and 6 display errors, the values on these meters will persist for about 8 seconds to give the user time to view them.

Writing a Parallel Communication Driver

The 1770-KFC15 module supports both full-duplex and half-duplex DF1 protocol over the RS-232C link. For details of the protocol format, refer to the document Allen-Bradley Data Highway/Data Highway Plus/DH-485 Communication Protocol and Command Set Reference Manual (1770-6.5.16).

DF1 Parallel Communication

To communicate over the parallel port between a host computer and a 1770-KFC15 module with firmware earlier than V4.2, use the link layer protocol of half-duplex DF1. In this setup, the computer is the host device and the module is the peripheral.

If the host supports bidirectional data on the parallel port you can use the Byte Transfer Mode. If the host supports output data only on the parallel port use Nibble Transfer Mode.

In Byte Transfer Mode, the host transmits and receives data one byte (eight bits) at a time. In Nibble Transfer Mode, the host transmits data one byte at a time, but receives data from the module one nibble (four bits) at a time.

The physical interface consists of eight data lines and nine handshaking lines. Four of the handshaking lines are controlled by the host and five by the module. The table below shows how the lines of the parallel port are used for both Byte and Nibble modes.

D-2 Writing a Parallel Communication Driver

Pin	Pin Notation	BYTE Mode	NIBBLE Mode
1	Strobe	Host Data Clock/ Acknowledge (ACK)	Host Data Clock/ Acknowledge (ACK)
2	Data 0	Data 0 to/from 1770-KFC15	Data 0 to 1770-KFC15
3	Data 1	Data 1 to/from 1770-KFC15	Data 1 to 1770-KFC15
4	Data 2	Data 2 to/from 1770-KFC15	Data 2 to 1770-KFC15
5	Data 3	Data 3 to/from 1770-KFC15	Data 3 to 1770-KFC15
6	Data 4	Data 4 to/from 1770-KFC15	Data 4 to 1770-KFC15
7	Data 5	Data 5 to/from 1770-KFC15	Data 5 to 1770-KFC15
8	Data 6	Data 6 to/from 1770-KFC15	Data 6 to 1770-KFC15
9	Data 7	Data 7 to/from 1770-KFC15	Data 7 to 1770-KFC15
10	Acknowledge	1770-KFC15 Data Clock/ Acknowledge (ACK)	1770-KFC15 Data Clock/ Acknowledge (ACK)
11	Busy	1770-KFC15 Flow Control (BUSY)	Data 3/Data7/BUSY from 1770-KFC15
12	P. End	1770-KFC15 End of Transmission (EOT)	Data 2/Data 6/EOT from 1770-KFC15
13	Select		Data 1/Data 5 from 1770-KFC15
14	Auto Feed	Host Flow Control (BUSY)	Host Flow Control (BUSY)
15	Error	1770-KFC15 End of Transmission (EOT)	Data 0/Data 4/EOT from 1770-KFC15
16	Initialize Printer	Host Initialization of 1770-KFC15 (INIT)	Host Initialization of 1770-KFC15 (INIT)
17	Select Input	Host Transmit Control (Host/1770-KFC15)	Host Transmit Control (Host/1770-KFC15)
18-25	Ground	Ground	Ground

The host communication software must turn on pin 17 (Host Transmit Control) to transmit data and reset it to receive data from the module. Every byte transmitted to the module must be clocked with a positive transition on pin 1. Every byte or nibble sent from the module must be clocked with a positive transition on pin 10.

The status indicators signify the following:

BUSY— a device is busy processing

EOT— a device has completed transmission

ACK— a transmission has been received

To reset parallel communications at any time, the host should reset pin 14 (Auto Feed) and set its data clock (pin 1). Then, the host device follows by resetting both pin 17 (Select Input) and pin 16 (Initialize Printer). The module should acknowledge by resetting its Busy and its Acknowledge lines.

The host should set Busy whenever it is reading a byte or nibble sent to it from a module, resetting it when ready for the next piece of the DF1 message.

In Nibble mode, receiving data from the module is a little more complex. The lower nibble of a byte is sent first, then the upper nibble on the next data block. After the host acknowledges the upper nibble, the module acknowledges by setting the data clock (pin 10) high. At this point, the status indicators Busy (pin 11) and EOT (pins 12 and 15) from the module can be read by the host device. The status indicators are overwritten with the next piece of data when the host Busy pin is reset.

Data Transmission

The following describes the actions that should be taken by both the host and module to send and transmit data. Note that 1 means logical 1 or high, regardless of whether or not the signal is normally active high or active low.

On power up, the host should do the following to initialize communication:

1. Set pin 1 (Strobe) to 1 and pin 14 (Auto Feed) to 0.
2. Set pin 17 (Select Input) and pin 16 (Initialize Printer) to 0. These two lines must be held low for a minimum of 50 ms to allow the module to detect them.

To send data from the host computer to the module, the host should:

1. Set pin 17 (Select Input) and pin 16 (Initialize Printer) to 1.
2. Check that the module's pin 11 (Busy) is set to 0.
3. Place data on the data lines.
4. Set pin 1 (Strobe) to 0 then 1.

To receive data from the host, the module:

1. Sets pin 11(Busy) to 1.
2. Reads data.
3. Sets pin 10 (Acknowledge) to 0 then 1.
4. Sets pin 11 (Busy) to 0.

At this point if the host has more data to send, it can repeat the above procedure until the entire packet is sent. Then, if data is expected from the module, the host should set pin 17 (Select Input) to 0 to enter either Byte or Nibble mode.

Data Transfer in Byte Mode

To send data in Byte mode from the module to the host, the module:

1. Checks that the host's pin 14 (Auto Feed) is set to 0.
2. Places data on the data lines.
3. Sets pin 10 (Acknowledge) to 0 then 1.

To receive data in Byte mode, the host:

1. Sets pin 14 (Auto Feed) to 1.
2. Reads the data.
3. Sets pin 1 (Strobe) to 0 then 1.

If there is more data to send, the module:

Sets pin 15 (Error) and pin 12 (P. End) to 0.

and the host should:

Set pin 14 (Auto Feed) to 0, then repeat its receive procedure.

If there is no more to send, the module:

1. Sets pin 15 (Error) and pin 12 (P. End) to 1.
2. Sets pin 10 (Acknowledge) to 1.

and the host sets pin 17 (Select Input) to 1.

Data Transfer in Nibble Mode

To send data in Nibble mode from the module to the host, the module:

1. Checks that the host's pin 14 (Auto Feed) is set to 0.
2. Places the lower nibble on the handshaking lines.
3. Sets pin 10 (Acknowledge) to 0 then 1.

To receive the lower nibble, the host:

1. Sets pin 14 (Auto Feed) to 1.
2. Reads the data.
3. Sets pin 1 (Strobe) to 0 then 1.
4. Sets pin 14 (Auto Feed) to 0.

To send the upper nibble, the module:

1. Checks that the host's pin 14 (Auto Feed) is set to 0.
2. Places the upper nibble on the handshaking lines.
3. Sets pin 10 (Acknowledge) to 0 then 1.

To receive the upper nibble, the host:

1. Sets pin 14 (Auto Feed) to 1.
2. Reads the data.
3. Sets pin 1 (Strobe) to 0 then 1.

At this point, the module sets pin 11 (Busy) to 0. This completes the transmission of one byte. If there is more data to send, the module:

Sets pin 15 (Error) and pin 12 (P. End) to 0.

and the host:

Sets pin 14 (Auto Feed) to 0, then repeats its receive procedure.

If there is no more to send, the module:

1. Sets pin 15 (Error) and pin 12 (P. End) to 1.
2. Sets pin 10 (Acknowledge) to 1.

and the host sets pin 17 (Select Input) to 1.

Numerics

- 1747-KFC15**
 - defined Preface-3
 - meters C-6
- 1756-CNB**
 - defined Preface-3
- 1770-KFC15**
 - defined Preface-3
- 1770-KFC15 diagnostic counters** 4-14
- 1770-KFC15 module**
 - overview of the 2-1

A

- abbreviations and terms** Preface-3
- AC power supply**
 - connecting to 3-5
- ACK** D-3
 - defined Preface-3
- advanced communication parameters** 4-8
- attaching the module to a wall or mounting bracket** 3-7
- auto-recovery** 6-9

B

- basic communication parameters** 4-4
- BUSY** D-3
- Byte Transfer Mode** D-1

C

- cables**
 - for network access port connection 3-4
 - for parallel port connection 3-4
 - for the RS-232C connector 3-3
- cabling and pinouts** B-1
 - for parallel port connection B-6
 - for RS-232C connection B-1
- centronics standard pinout** B-6
- certifications** A-3
- communicating with the module** 6-1
- communication parameters**
 - verifying the 4-13
- communication protocol** 1-1

configuration changes

- save
 - successful 4-12
 - unsuccessful 4-12
- configuration panel displays** 4-1
- configuration panel pushbuttons** 4-2
- configuration procedures**
 - overview of 4-1
- configuring the advanced communication parameters** 4-8
- configuring the basic parameters** 4-4
- configuring the module** 4-1
- configuring the module by using pushbuttons** 4-3
- connecting a device**
 - to the network access port 3-4
- connecting multiple modules to one host by using modems** 1-4
- connecting to a host**
 - through the parallel port 3-4
 - through the RS-232C port 3-2
- connecting to the AC power supply** 3-5
- connecting to the ControlNet cable system** 3-6
- ControlNet**
 - defined Preface-3
 - system overview 1-1
- ControlNet architecture** 1-2
- ControlNet cable system**
 - connecting to the 3-6
- ControlNet LED** 2-3

D

- data throughput** 6-2
- data transfer**
 - in byte mode D-4
 - in nibble mode D-5
- data transmission** D-4
- default DF1 address** 6-6
- device connections** 2-2
 - network access port 2-2
 - parallel port 2-2
 - RS-232C serial port 2-2
- DF1**
 - communication 6-1
 - default address 6-6
 - defined Preface-3

- diagnostic command support C-1
- parallel communication D-1
- RSLinx driver anomaly 6-8
- SRC and DST address 6-7

DH+

- defined Preface-3

DH+ PCCC message

- defined Preface-3

DHRIO

- defined Preface-3

diagnostic counter reset C-6

- command format C-6
- reply format C-6

diagnostic counters

- 1770-KFC15 4-14

diagnostic loop C-2

- command format C-2
- reply format C-2

diagnostic read counters C-2

- command format C-2
- reply format C-3
- reply values
 - 8-bit wide old counter descriptions C-3

dimensions A-2

displays

- configuration panel 4-1

DST

- defined Preface-3

E

EIA standard pinout B-1

electrostatic damage 3-1

electrostatic discharge

- preventing Preface-5

embedded responses 6-5

enclosure and environment Preface-5

environment and enclosure Preface-5

EOT D-3

exit without saving 4-13

extra-hop feature

- configure a path method 5-3
 - address/slot number 5-5
 - example 1 5-5
 - example 2 5-7
 - path length 5-3
 - port numbers 5-4
- no configuration method 5-2
- understanding the 5-1

F

factory defaults

- setting 4-13

fault descriptions 7-4

file names 7-6

full duplex

- defined Preface-3

full-duplex serial protocol 6-2

H

half duplex

- defined Preface-3

half-duplex multi-drop serial network 6-3

half-duplex protocol

- one-circuit system 6-3
- two-circuit system 6-3

host cable system, planning the 1-3

host LED 2-3

I

installation procedure 3-2

installing the module 3-1

interface compatibility 2-3

interpreting the seven-segment LED displays 7-4

interpreting the status LEDs 7-1

introducing the module 2-1

L

LEDs 2-3

M

message buffers 6-9

message reply time-out 6-6

meters

- 1747-KFC15 C-6

N

NAK

- defined Preface-3

NAP

- defined Preface-3

network

defined Preface-3
network access cable 3-4
network access port 2-2
network address
 defined Preface-3
network update time (NUT) 1-1
new KFC
 defined Preface-3
Nibble Transfer Mode D-1
node
 defined Preface-3
NUT
 defined Preface-3
 maintenance 1-2
 scheduled 1-2
 unscheduled 1-2

O

old KFC
 defined Preface-4
overview of configuration procedures 4-1
overview of ControlNet 1-1
overview of the 1770-KFC15 module 2-1

P

parallel communication 6-4
parallel port 2-2
 defined Preface-4
parallel port activity indicator 3-4
parallel port interface connector 3-4
parameters
 advanced communication 4-8
 basic communication 4-4
PCCC 5-1
 defined Preface-4
physical characteristics 1-1
pinouts B-1
planning
 for an RS-232C serial port 1-3
 the host cable system 1-3
product specifications A-1
purpose of the manual Preface-1
pushbuttons
 configuration display 4-2
 DATA 4-2
 EXIT 4-2
 using to configure the module 4-3

VIEW 4-2

R

reading 1770-KFC15 counters with a diagnostic command 4-14
related products Preface-2
related publications Preface-1
repeater
 defined Preface-4
RIO
 defined Preface-4
RS-232C baud rates 3-2
RS-232
 interface connector 3-3
RS-232C
 activity indicator 3-3
RS-232C port
 defined Preface-4
RS-232C serial port 2-2
 planning for an 1-3
RSLinx DF1 driver anomaly 6-8

S

saving configuration changes 4-12
scheduled data 1-2
segment
 defined Preface-4
serial communication 6-2
serial port
 defined Preface-4
setting factory defaults 4-13
specifications
 product A-1
SRC
 defined Preface-4
standard PCCC message
 defined Preface-4
status LED 2-3
subnet
 defined Preface-4

T

tap
 defined Preface-4
terminator
 defined Preface-4

Index-4

terms and abbreviations Preface-3

troubleshooting the module 7-1

trunkline

defined Preface-4

trunkline section

defined Preface-4

U

understanding the ControlNet architecture 1-2

unscheduled data 1-2

V

verifying the communication parameters 4-13

viewing basic parameter settings 4-3

W

writing a parallel communication driver D-1

Rockwell Automation Support

Rockwell Automation provides technical information on the web to assist you in using our products. At <http://support.rockwellautomation.com>, you can find technical manuals, a knowledge base of FAQs, technical and application notes, sample code and links to software service packs, and a MySupport feature that you can customize to make the best use of these tools.

For an additional level of technical phone support for installation, configuration and troubleshooting, we offer TechConnect Support programs. For more information, contact your local distributor or Rockwell Automation representative, or visit <http://support.rockwellautomation.com>.

Installation Assistance

If you experience a problem with a hardware module within the first 24 hours of installation, please review the information that's contained in this manual. You can also contact a special Customer Support number for initial help in getting your module up and running:

United States	1.440.646.3223 Monday – Friday, 8am – 5pm EST
Outside United States	Please contact your local Rockwell Automation representative for any technical support issues.

New Product Satisfaction Return

Rockwell tests all of our products to ensure that they are fully operational when shipped from the manufacturing facility. However, if your product is not functioning and needs to be returned:

United States	Contact your distributor. You must provide a Customer Support case number (see phone number above to obtain one) to your distributor in order to complete the return process.
Outside United States	Please contact your local Rockwell Automation representative for return procedure.

ControlNet is a trademark of ControlNet International.

Allen-Bradley, ControllLogix, Flex, PLC-5, and Rockwell Automation are trademarks of Rockwell Automation, Inc.

RSLinx, RSLogix 5, RSLogix 500, RSLogix 5000, RSNetWorx, and RSView 32 are trademarks of Rockwell Software, Inc.

Trademarks not belonging to Rockwell Automation are property of their respective companies.

www.rockwellautomation.com

Power, Control and Information Solutions Headquarters

Americas: Rockwell Automation, 1201 South Second Street, Milwaukee, WI 53204-2496 USA, Tel: (1) 414.382.2000, Fax: (1) 414.382.4444

Europe/Middle East/Africa: Rockwell Automation, Vorstlaan/Boulevard du Souverain 36, 1170 Brussels, Belgium, Tel: (32) 2 663 0600, Fax: (32) 2 663 0640

Asia Pacific: Rockwell Automation, Level 14, Core F, Cyberport 3, 100 Cyberport Road, Hong Kong, Tel: (852) 2887 4788, Fax: (852) 2508 1846

Publication 1770-UM520C-EN-P - July 2004

PN 957899-17

Supersedes Publication 1770-UM520B-EN-P - August 2003 and 1770-RN001A-EN-P - May 2002

Copyright © 2004 Rockwell Automation, Inc. All rights reserved. Printed in USA