



1771-N Series I/O to 1756 ControlLogix I/O

(Cat 1492-CONACAB_ _ _N1 thru N8)

I. Description of the Existing 1771-N Series I/O Wiring System

The 1771-N Series High Resolution Isolated Analog I/O modules were designed to be used with 1771 Remote Termination Panels (RTPs) and connected by a 6ft or 15ft cable, as follows.

The N-series modules are cable-connected to a remote termination panel using Catalog Number 1771-NC6 (6 ft) or 1771-NC15 (15 ft) cables.

Variations of remote termination panels are used, depending on the type of module used. These are:

| Catalog Number | Description |
|---|---|
| 1771-RTP1 | has cold junction compensation for thermocouples |
| 1771-RTP3 | incorporates resistors and fuses; used primarily for 4 - 20mA inputs when using $\pm 5V$ inputs (Uses 5mm x 20mm fast acting 1/4A fuses such as Bussmann GMA-1/4, 250V / 250mA) |
| 1771-RTP4 | a general use block with straight-thru wiring that can be used for all applications except thermocouples |
| 1771-RT41 | a 4-channel block with cold junction compensation for thermocouples |
| 1771-RT44 | a general use 4-channel block with straight-thru wiring that can be used for all applications except thermocouples |
| RTP4 and RT44 can be used with thermocouples if a method of odd junction compensation is provided at the interface of thermocouple and copper wires within the system | |

The remote termination panels are designed for mounting on standard DIN 1 or DIN 3 mounting rails.

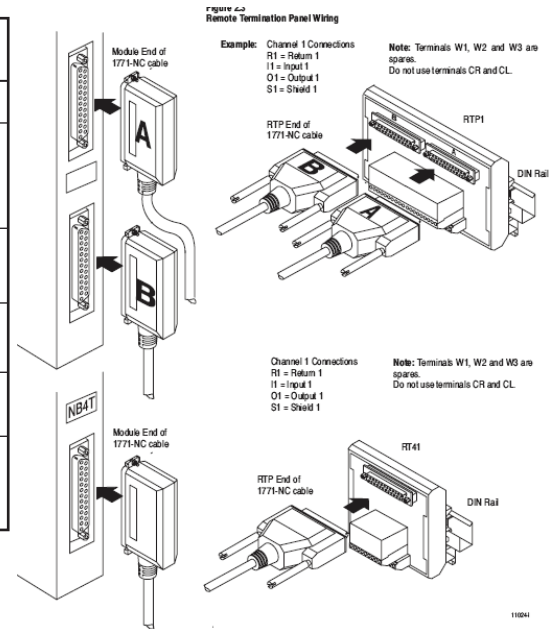

| Module | Channel 1 | Channel 2 | Channel 3 | Channel 4 | Channel 5 | Channel 6 | Channel 7 | Channel 8 |
|-----------|-------------------------|-------------------------|-------------------------|-------------------------|-------------------------|-------------------------|-------------------------|-------------------------|
| 1771-NIS | 4 - 20mA | 4 - 20mA | 4 - 20mA | 4 - 20mA | 4 - 20mA | 4 - 20mA | 4 - 20mA | 4 - 20mA |
| 1771-NIV | $\pm 5V$ ($\pm 20mA$) | $\pm 5V$ ($\pm 20mA$) | $\pm 5V$ ($\pm 20mA$) | $\pm 5V$ ($\pm 20mA$) | $\pm 5V$ ($\pm 20mA$) | $\pm 5V$ ($\pm 20mA$) | $\pm 5V$ ($\pm 20mA$) | $\pm 5V$ ($\pm 20mA$) |
| 1771-NIV1 | $\pm 10V$ | $\pm 10V$ | $\pm 10V$ | $\pm 10V$ | $\pm 10V$ | $\pm 10V$ | $\pm 10V$ | $\pm 10V$ |
| 1771-NIVR | $\pm 5V$ ($\pm 20mA$) | $\pm 5V$ ($\pm 20mA$) | $\pm 5V$ ($\pm 20mA$) | $\pm 5V$ ($\pm 20mA$) | RTD | RTD | RTD | RTD |
| 1771-NIVT | $\pm 5V$ ($\pm 20mA$) | $\pm 5V$ ($\pm 20mA$) | $\pm 5V$ ($\pm 20mA$) | $\pm 5V$ ($\pm 20mA$) | $\pm 100mV/TC$ | $\pm 100mV/TC$ | $\pm 100mV/TC$ | $\pm 100mV/TC$ |
| 1771-NR | RTD | RTD | RTD | RTD | RTD | RTD | RTD | RTD |
| 1771-NT1 | $\pm 100mV/TC$ | $\pm 100mV/TC$ | $\pm 100mV/TC$ | $\pm 100mV/TC$ | $\pm 100mV/TC$ | $\pm 100mV/TC$ | $\pm 100mV/TC$ | $\pm 100mV/TC$ |
| 1771-NT2 | -5 / +55mV/TC | -5 / +55mV/TC | -5 / +55mV/TC | -5 / +55mV/TC | -5 / +55mV/TC | -5 / +55mV/TC | -5 / +55mV/TC | -5 / +55mV/TC |
| 1771-NOC | 0 - 25mA out | 0 - 25mA out | 0 - 25mA out | 0 - 25mA out | 0 - 25mA out | 0 - 25mA out | 0 - 25mA out | 0 - 25mA out |
| 1771-NOV | $\pm 10V$ out | $\pm 10V$ out | $\pm 10V$ out | $\pm 10V$ out | $\pm 10V$ out | $\pm 10V$ out | $\pm 10V$ out | $\pm 10V$ out |

II. Description of the Conversion Solution

This conversion from the 1771-N Series I/O to a 1756 ControlLogix I/O is accomplished simply by replacing the (2) existing cables A & B with (2) of the following new 1492 cables. Each of these cables has a connector on one end that attaches directly to the existing 1771 RTP. On the other end of the new cable is (1) 1756 Removable Terminal Block (RTB) for connection to the new 1756 ControlLogix I/O Module. The I/O signals are routed from the existing 1771 RTP through the 1492 cables to the appropriate terminals on the 1756 I/O module, per the Wiring Diagrams in this Installation Manual. This allows the conversion to be completed without the removal of any field wires from the existing 1771-RTP.

**All solutions except
1771-NT1, 1771-NT2 and 1771-NOC (Non-Isolated)**

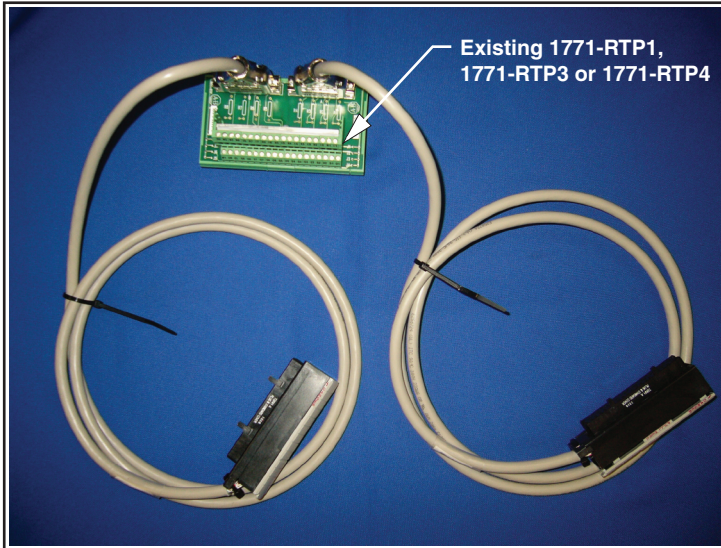

**Cable Catalog Numbers:
1492-CONACAB020N5
1492-CONACAB020N6**

1771-NT1 to 1756-IT6I and 1771-NT2 to 1756-IT6I2

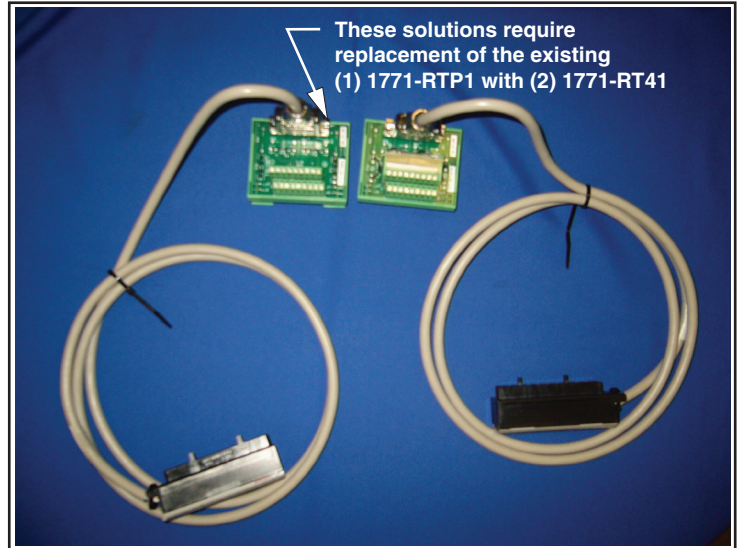

**Cable Catalog Numbers:
1492-CONACAB020N1
1492-CONACAB020N2
1492-CONACAB020N3
1492-CONACAB020N4
1492-CONACAB020N5
1492-CONACAB020N7**

1771-NOC to 1756-OF8 (Non-Isolated)

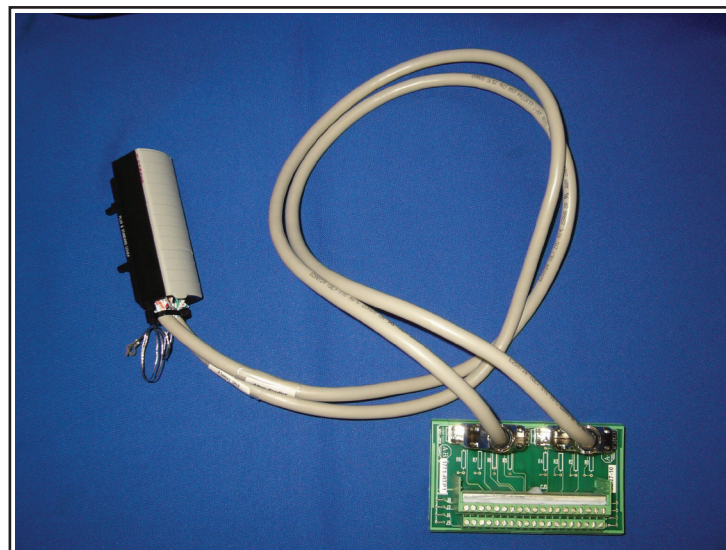

**Cable Catalog Number:
1492-CONACAB020N8**

III. Compatibility for I/O Modules

Table 2a: Conversion Cables for Bulletin 1771-N Series I/O

| 1771 Analog I/O Module ^① | 1756 Analog I/O Module ^① | 1492 "A" and "B" Cables ^④ | 1492 Cable Descripton ^⑤ |
|--|--|---|---------------------------------------|
| 1771-NOC | 1756-OF6CI (Qty 2) | 1492-CONACAB020N1 (Qty 2) | Current, Isolated |
| 1771-NOC ^② | 1756-OF8 (Qty 1) | 1492-CONACAB020N8 (Qty 1) | Current, Non-Isolated |
| 1771-NIS | 1756-IF6CIS (Qty 2) | 1492-CONACAB020N2 (Qty 2) | Current |
| 1771-NIV ^③ | 1756-IF6I (Qty 2) | 1492-CONACAB020N3 (Qty 1 or 2) | Current |
| | | 1492-CONACAB020N7 (Qty 1 or 2) | Voltage |
| 1771-NR | 1756-IR6I (Qty 2) | 1492-CONACAB020N4 (Qty 2) | RTD |
| 1771-NT1 ^⑥ | 1756-IT6I (Qty 2) | 1492-CONACAB020N5 (Qty 2) | Thermocouple |
| 1771-NOV | 1756-OF6VI (Qty 2) | 1492-CONACAB020N1 (Qty 2) | Voltage |
| 1771-NIV1 | 1756-IF6I (Qty 2) | 1492-CONACAB020N7 (Qty 2) | Voltage |
| 1771-NT2 ^⑥ | 1756-IT6I2 (Qty 2) | 1492-CONACAB020N6 (Qty 2) | Thermocouple |

Foot Notes:

- ① To understand any issues concerning I/O module compatibility refer to the Installation Manuals for the specific I/O modules involved.
- ② Cable 1492-CONACAB020N8 has (2) connectors on one end for the RTP, so only (1) Cable is required - see the Wiring Diagrams and Photos for details.
- ③ Three conversions are possible using these two cables - (8 Voltage) or (8 Current) or (4 Voltage & 4 Current) - see the Wiring Diagrams for further details.
- ④ These catalog numbers are for a 2.0M cable length. A 5.0M cable is also available. Change the 3 numerals in the middle of the catalog number from "020" to "050" (Example: 1492-CONACAB020N1 becomes 1492-CONACAB050N1).
- ⑤ Only 2 cables can be used at one time. Each cable attaches to 1 of the 2 connectors on the existing RTP module. Each cable converts 4 of the 1771 channels to 4 of the 1756 channels. The other end of the cable attaches to 1 of the 2 new 1756 modules.
- ⑥ This conversion solution requires replacement of the existing (1) 1771-RTP1 interface module with (2) 1771-RT41 interface modules. Each 1771-RTP1 module has a cold junction compensation thermocouple attached to the interface module.

IV. Compatibility for Combination I/O Modules

Table 2B: Conversion Cables for Bulletin 1771-N Series I/O Combination Modules

| 1771 Analog I/O Module ^① | 1756 Analog I/O Module ^① | 1492 "A" and "B" Cables ^④ | 1492 Cable Descriptor ^⑤ |
|--|--|---|---------------------------------------|
| 1771-NIVR ^② | 1756-IR6I (Qty 1) | "B" Cable = 1492-CONACAB020N4 | RTD |
| | 1756-IF6I (Qty 1) | "A" Cable = 1492-CONACAB020N7 | Voltage |
| 1771-NIVR ^② | 1756-IR6I (Qty 1) | "B" Cable = 1492-CONACAB020N4 | RTD |
| | 1756-IF6I (Qty 1) | "A" Cable = 1492-CONACAB020N3 | Current |
| 1771-NIVT ^③ | 1756-IT6I (Qty 1) | "B" Cable = 1492-CONACAB020N5 | Thermocouple |
| | 1756-IF6I (Qty 1) | "A" Cable = 1492-CONACAB020N7 | Voltage |
| 1771-NIVT ^③ | 1756-IT6I (Qty 1) | "B" Cable = 1492-CONACAB020N5 | Thermocouple |
| | 1756-IF6I (Qty 1) | "A" Cable = 1492-CONACAB020N3 | Current |

Foot Notes:

- ① To understand any issues concerning I/O module compatibility refer to the Installation Manuals for the specific I/O modules involved.
- ② Two conversions are possible using these two cables - (4 Voltage & 4 RTD) or (4 Current & 4 RTD) - see the Wiring Diagrams for further details.
- ③ Two conversions are possible using these two cables - (4 Voltage & 4 Thermocouple) or (4 Current & 4 Thermocouple) - see the Wiring Diagrams for further details.
- ④ These catalog numbers are for a 2.0M cable length. A 5.0M cable is also available. Change the 3 numerals in the middle of the catalog number from "020" to "050" (Example: 1492-CONACAB020N1 becomes 1492CONACAB050N1).
- ⑤ Only 2 cables can be used at one time. Each cable attaches to 1 of the 2 connectors on the existing RTP module. Each cable converts 4 of the 1771 channels to 4 of the 1756 channels. The other end of the cable attaches to 1 of the 2 new 1756 modules.



WARNING

There are several key application considerations and system specifications (bottom of drawing) when using these components (conversion module, cable and input module). Read and understand these considerations before installation.

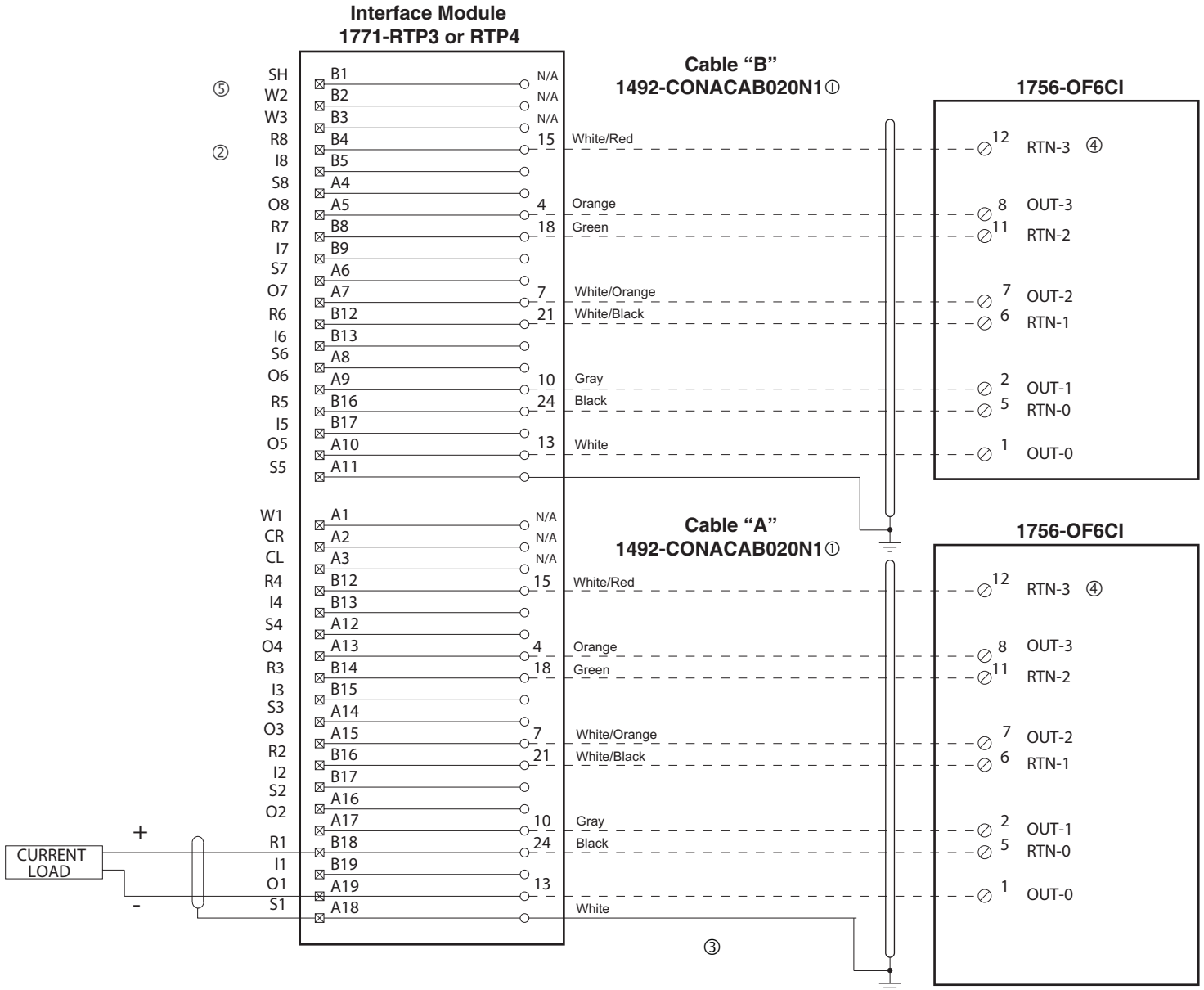

Conversion Module Installation and Application Considerations

- ① Cables are available in 2.0m, or 5.0m
- ② Terminals starting with A are the lower row of terminals, B terminals are the upper row.
- ③ Follow your PLC Analog User Manual for proper shield grounding instructions.
- ④ RTN terminals are internally connected on the 1756-OF6CI.
- ⑤ Terminals w1, w2, w3, are spares used for field wire convenience. NOTE: This is only true for modules RTP3 and RTP4. The Bul. 1492 cable does not connect to these terminals.

[Reference Doc: 41171-072 (Version 00)]

V. Wiring Diagrams (Continued)

Conversion: 1771-NOC (1) To 1756-OF8 (1) (Current, Non-Isolated) Using Existing 1771-RTP3 or RTP4 Interface Module



WARNING

There are several key application considerations and system specifications (bottom of drawing) when using these components (conversion module, cable and input module). Read and understand these considerations before installation.

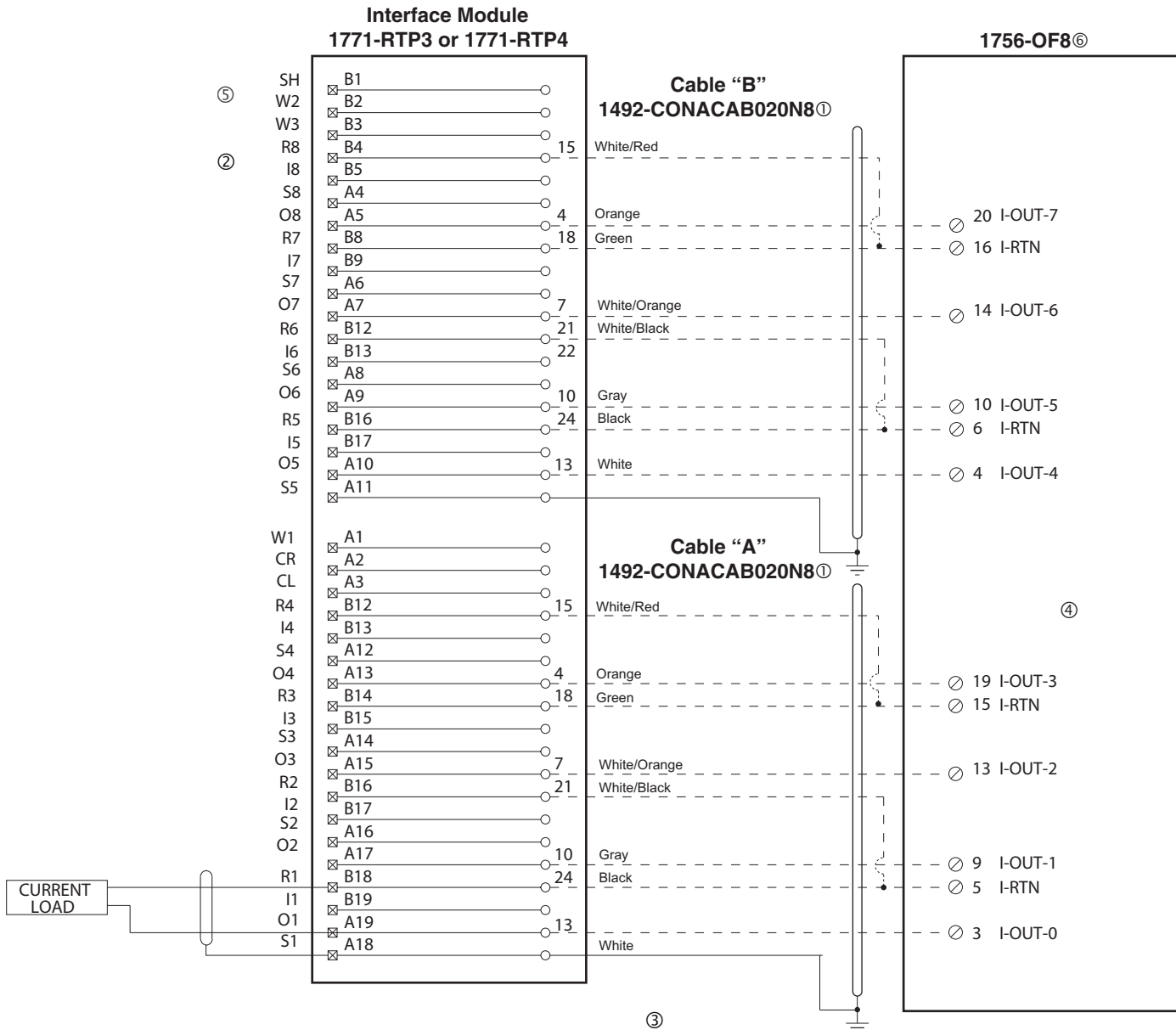

Conversion Module Installation and Application Considerations

- ① Cables are available in 2.0m, or 5.0m
- ② Terminals starting with A are the lower row of terminals, B terminals are the upper row.
- ③ Follow your PLC Analog User Manual for proper shield grounding instructions.
- ④ RTN terminals are internally connected on the 1756-OF8.
- ⑤ Terminals w1, w2, w3, are spares used for field wire convenience. NOTE: This is only true for module RTP3 and RTP4. The Bul. 1492 cable does not connect to these terminals.
- ⑥ The 1771-NOC module provides channel to channel isolation, the 1756-OF8 does not. A conversion from 1771-NOC to an isolated 1756-OF8 is available.

[Reference Doc: 41171-079 (Version 00)]



WARNING

There are several key application considerations and system specifications (bottom of drawing) when using these components (conversion module, cable and input module). Read and understand these considerations before installation.

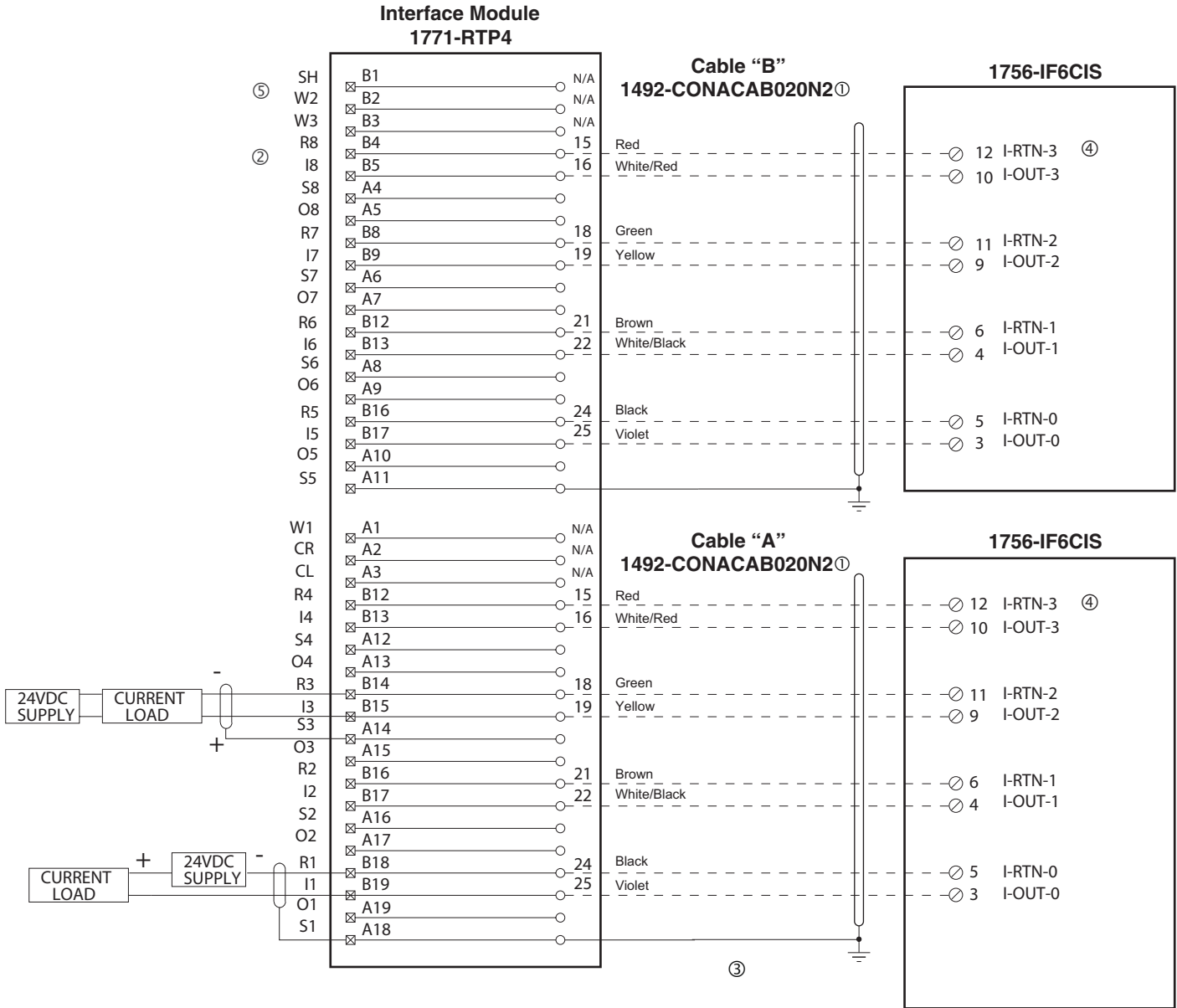

Conversion Module Installation and Application Considerations

- ① Cables are available in 2.0m, or 5.0m
- ② Terminals starting with A are the lower row of terminals, B terminals are the upper row.
- ③ Follow your PLC Analog User Manual for proper shield grounding instructions.
- ④ RTN terminals are internally connected on the 1756-IF6CIS.
- ⑤ Terminals w1, w2, w3, are spares used for field wire convenience. NOTE: This is only true for module RTP4. The Bul. 1492 cable does not connect to these terminals.

[Reference Doc: 41171-073 (Version 00)]



WARNING

There are several key application considerations and system specifications (bottom of drawing) when using these components (conversion module, cable and input module). Read and understand these considerations before installation.

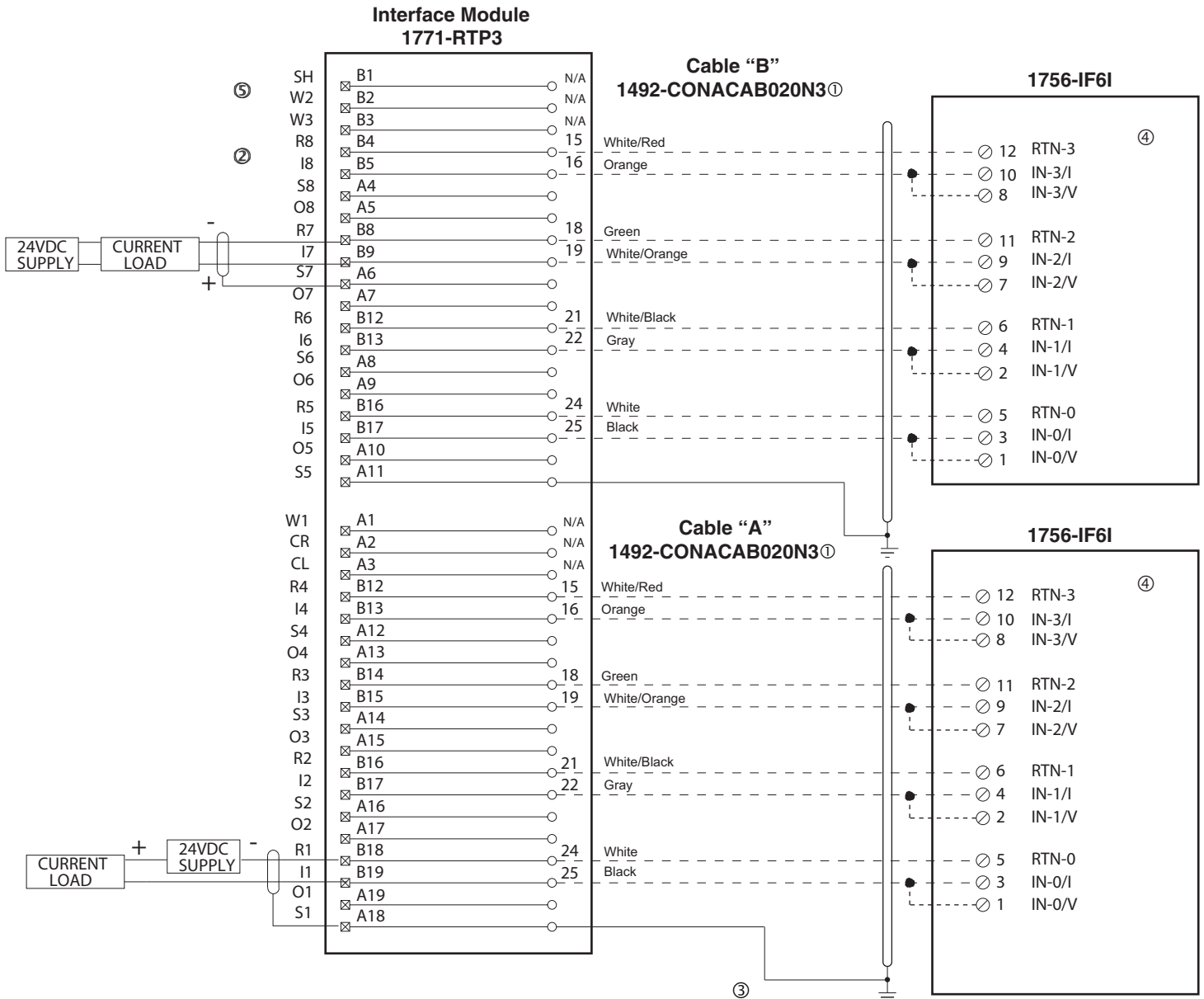

Conversion Module Installation and Application Considerations

- ① Cables are available in 2.0m, or 5.0m
- ② Terminals starting with A are the lower row of terminals, B terminals are the upper row.
- ③ Follow your PLC Analog User Manual for proper shield grounding instructions.
- ④ RTN terminals are internally connected on the 1756-IF6I.
- ⑤ Terminals w1, w2, w3, are spares used for field wire convenience. NOTE: This is only true for module RTP3. The Bul. 1492 cable does not connect to these terminals.

[Reference Doc: 41171-074 (Version 00)]



WARNING

There are several key application considerations and system specifications (bottom of drawing) when using these components (conversion module, cable and input module). Read and understand these considerations before installation.

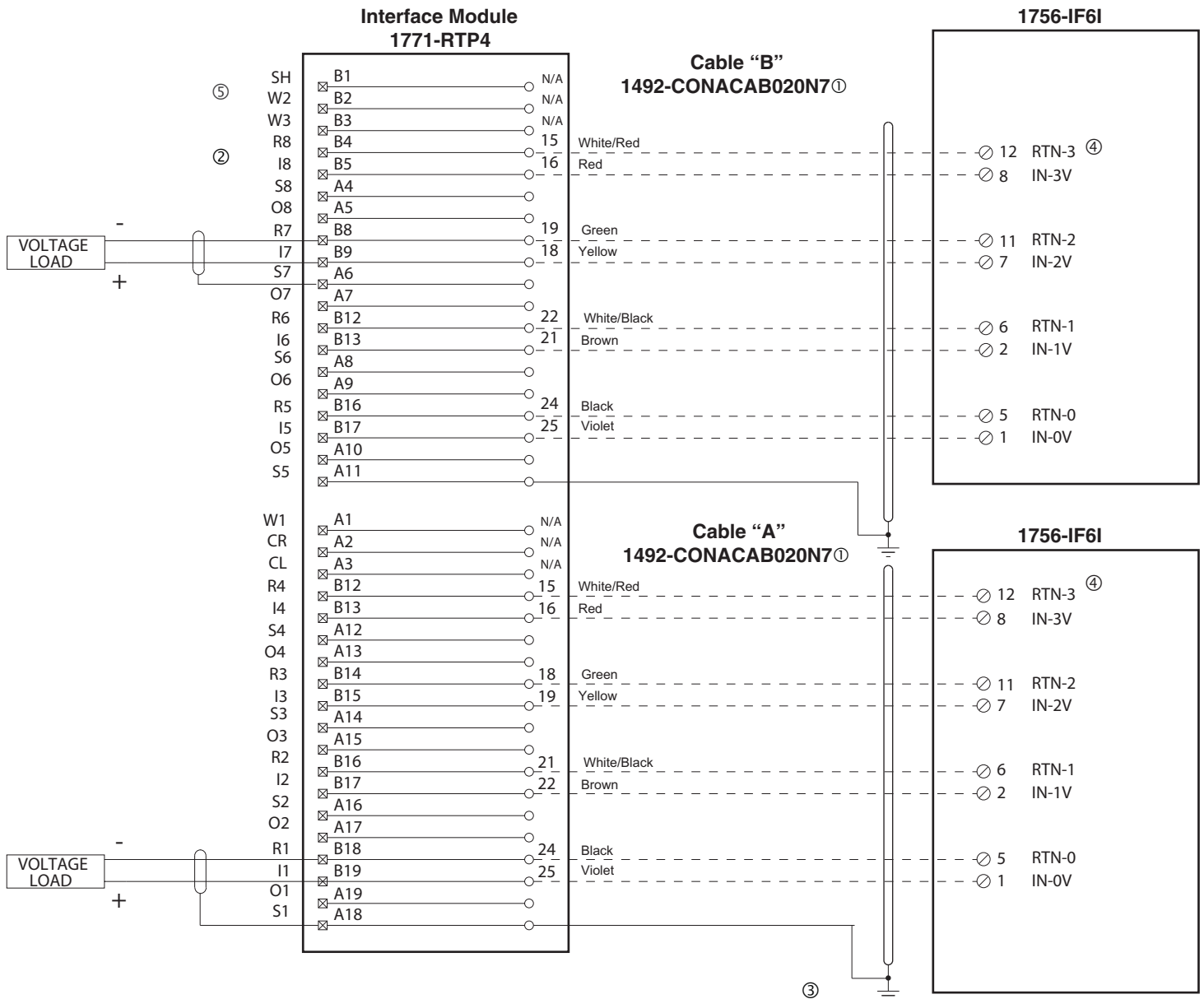

Conversion Module Installation and Application Considerations

- ① Cables are available in 2.0m, or 5.0m
- ② Terminals starting with A are the lower row of terminals, B terminals are the upper row.
- ③ Follow your PLC Analog User Manual for proper shield grounding instructions.
- ④ RTN terminals are internally connected on the 1756-IF6I.
- ⑤ Terminals w1, w2, w3, are spares used for field wire convenience. NOTE: This is only true for module RTP4. The Bul. 1492 cable does not connect to these terminals.

[Reference Doc: 41171-080 (Version 00)]

Conversion: 1771-NIV (1) To
1756-IF6I (1) (Current) And 1756-IF6I (1) (Voltage)
Using Existing 1771-RTP4 Interface Module



WARNING

There are several key application considerations and system specifications (bottom of drawing) when using these components (conversion module, cable and input module). Read and understand these considerations before installation.

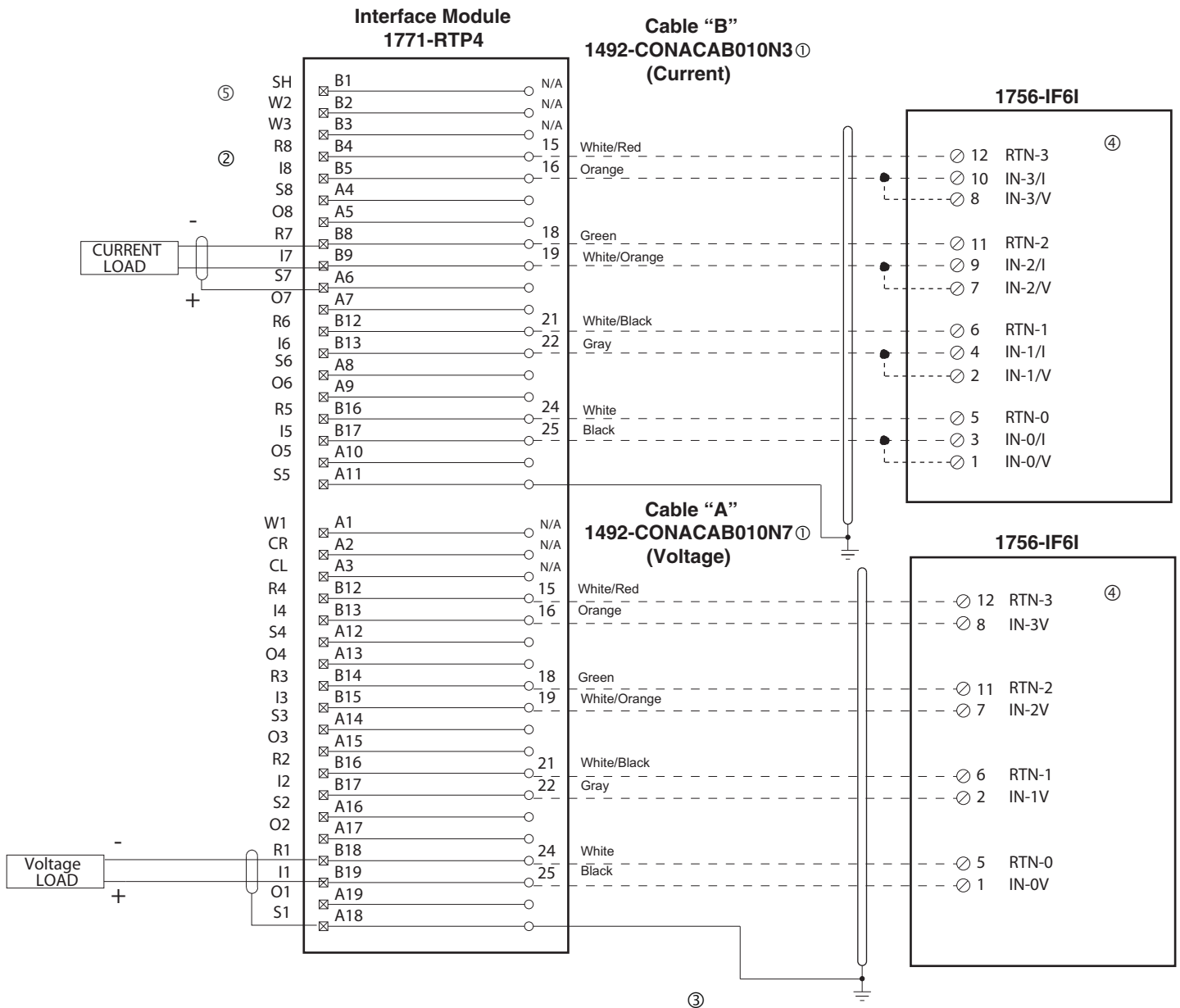

Conversion Module Installation and Application Considerations

- ① Cables are available in 2.0m, or 5.0m
- ② Terminals starting with A are the lower row of terminals, B terminals are the upper row.
- ③ Follow your PLC Analog User Manual for proper shield grounding instructions.
- ④ RTN terminals are internally connected on the 1756-IF6I.
- ⑤ Terminals w1, w2, w3, are spares used for field wire convenience. NOTE: This is only true for module RTP3. The Bul. 1492 cable does not connect to these terminals.

[Reference Doc: 41171-038 (Version 00)]



WARNING

There are several key application considerations and system specifications (bottom of drawing) when using these components (conversion module, cable and input module). Read and understand these considerations before installation.

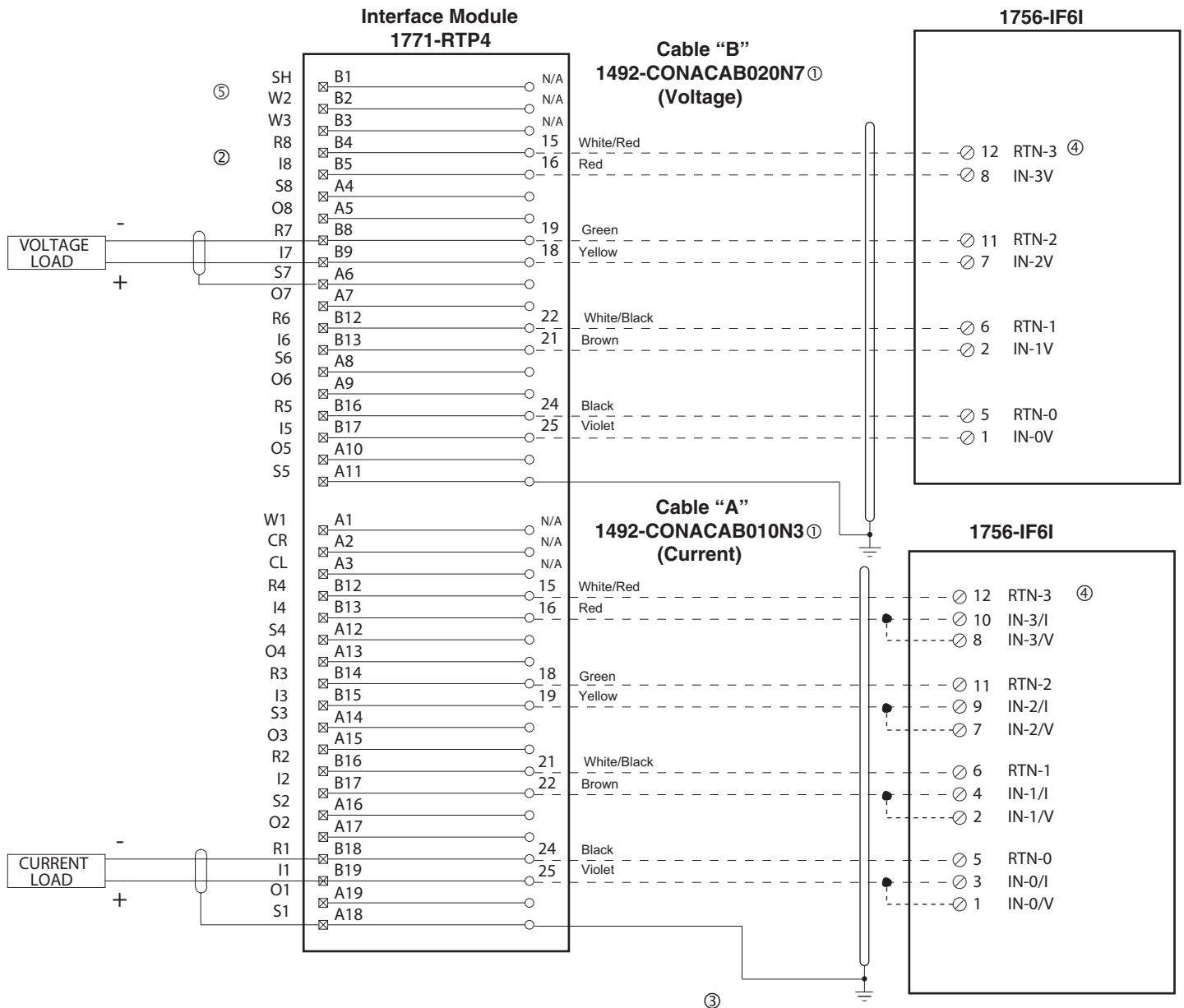

Conversion Module Installation and Application Considerations

- ① Cables are available in 2.0m, or 5.0m
- ② Terminals starting with A are the lower row of terminals, B terminals are the upper row.
- ③ Follow your PLC Analog User Manual for proper shield grounding instructions.
- ④ RTN terminals are internally connected on the 1756-IF6I.
- ⑤ Terminals w1, w2, w3, are spares used for field wire convenience. NOTE: This is only true for module RTP4. The Bul. 1492 cable does not connect to these terminals.

[Reference Doc: 41171-039 (Version 00)]



WARNING

There are several key application considerations and system specifications (bottom of drawing) when using these components (conversion module, cable and input module). Read and understand these considerations before installation.

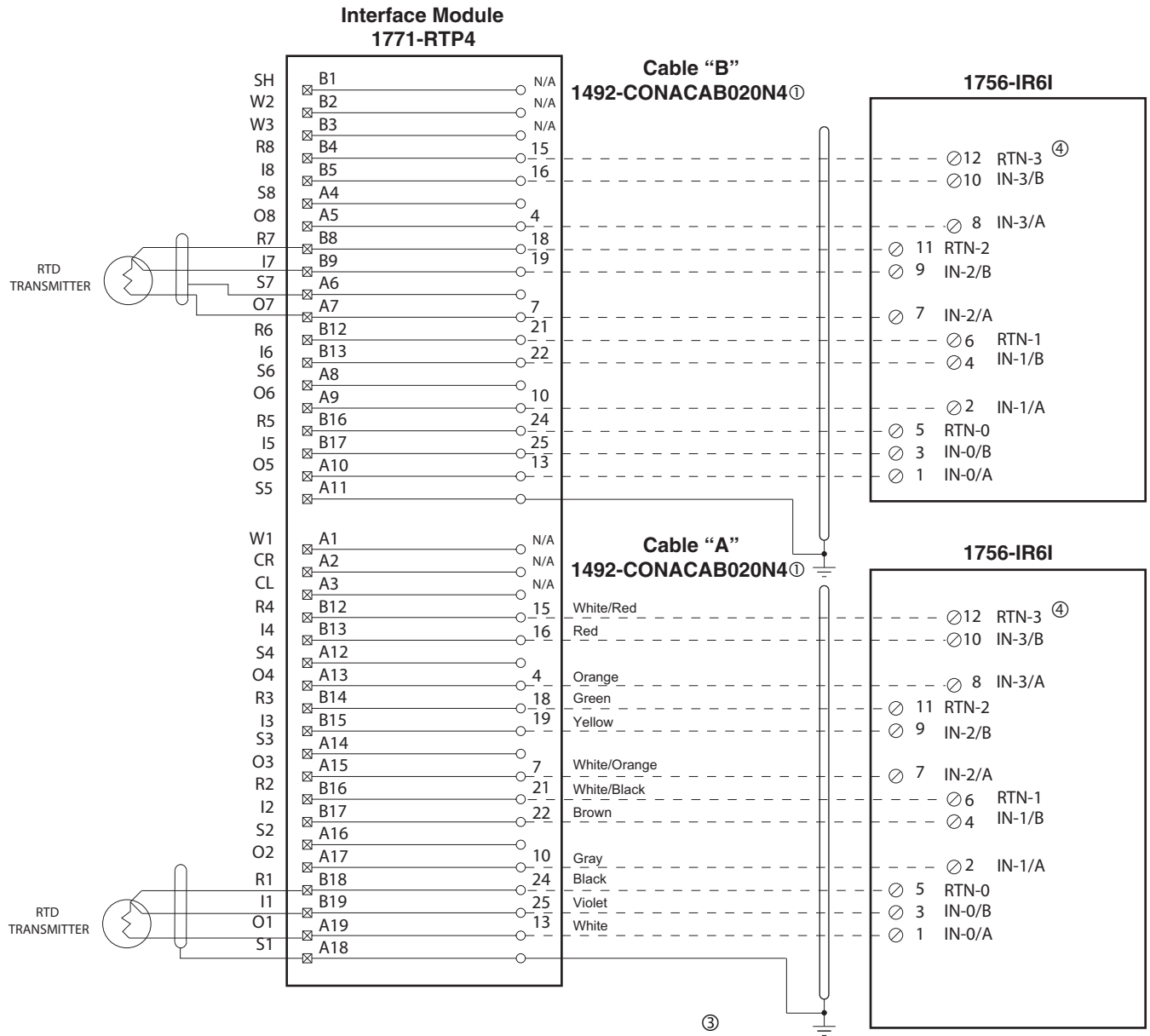

Conversion Module Installation and Application Considerations

- ① Cables are available in 2.0m, or 5.0m
- ② Terminals starting with A are the lower row of terminals, B terminals are the upper row.
- ③ Follow your PLC Analog User Manual for proper shield grounding instructions.
- ④ RTN terminals are internally connected on the 1756-IR6I.
- ⑤ Terminals w1, w2, w3, are spares used for field wire convenience. NOTE: This is only true for module RTP4. The Bul. 1492 cable does not connect to these terminals.

[Reference Doc: 41171-075 (Version 00)]



WARNING

There are several key application considerations and system specifications (bottom of drawing) when using these components (conversion module, cable and input module). Read and understand these considerations before installation.

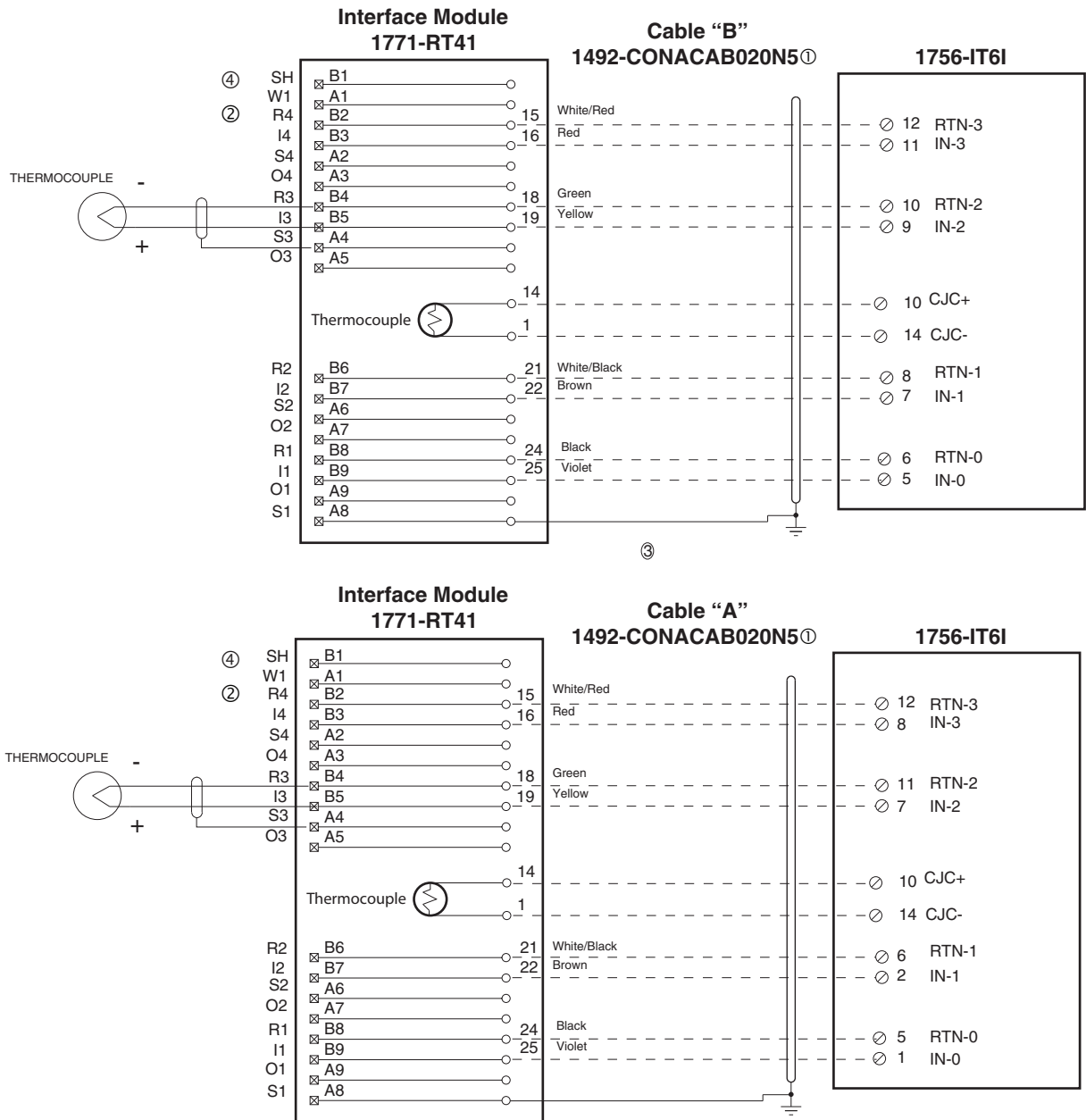

Conversion Module Installation and Application Considerations

- ① Cables are available in 2.0m, or 5.0m
- ② Terminals starting with A are the lower row of terminals, B terminals are the upper row.
- ③ Follow your PLC Analog User Manual for proper shield grounding instructions.
- ④ RTN terminals are internally connected on the 1756-IT6I.
- ⑤ Terminals w1, w2, w3, are spares used for field wire convenience. NOTE: This is only true for module RTP4. The Bul. 1492 cable does not connect to these terminals.
- ⑥ This conversion solution requires replacement of the existing (1) 1771-RTP1 interface module with (2) 1771-RT41 interface modules. Each 1771-RTP1 and RT41 module has their own cold junction compensation thermocouple attached to the interface module.

[Reference Doc: 41171-076 (Version 00)]



WARNING

There are several key application considerations and system specifications (bottom of drawing) when using these components (conversion module, cable and input module). Read and understand these considerations before installation.

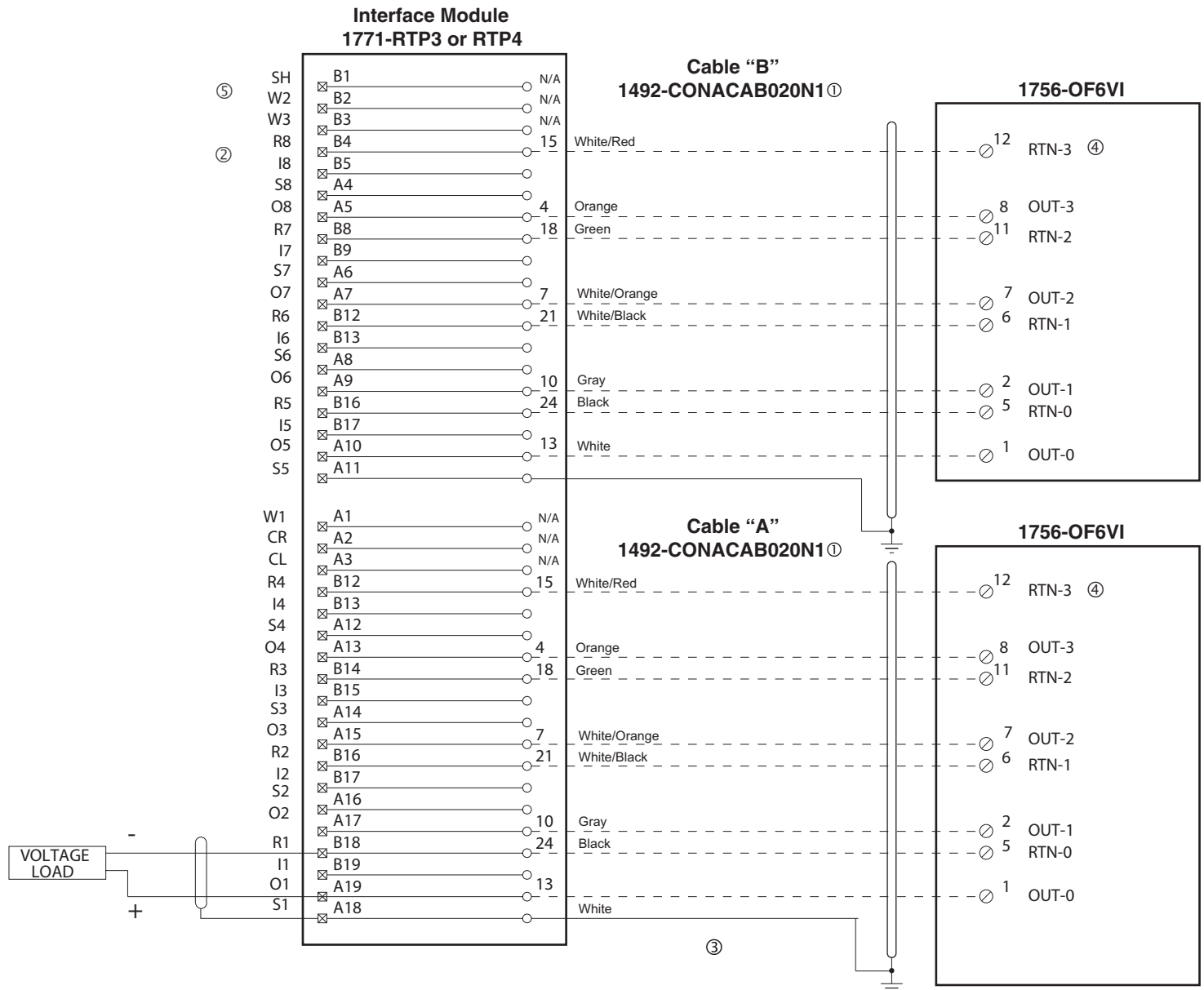

Conversion Module Installation and Application Considerations

- ① Cables are available in 2.0m, or 5.0m
- ② Terminals starting with A are the lower row of terminals, B terminals are the upper row.
- ③ Follow your PLC Analog User Manual for proper shield grounding instructions.
- ④ RTN terminals are internally connected on the 1756-OF6VI.
- ⑤ Terminals w1, w2, w3, are spares used for field wire convenience. NOTE: This is only true for modules RTP3 and RTP4. The Bul. 1492 cable does not connect to these terminals.

[Reference Doc: 41171-081 (Version 00)]



WARNING

There are several key application considerations and system specifications (bottom of drawing) when using these components (conversion module, cable and input module). Read and understand these considerations before installation.

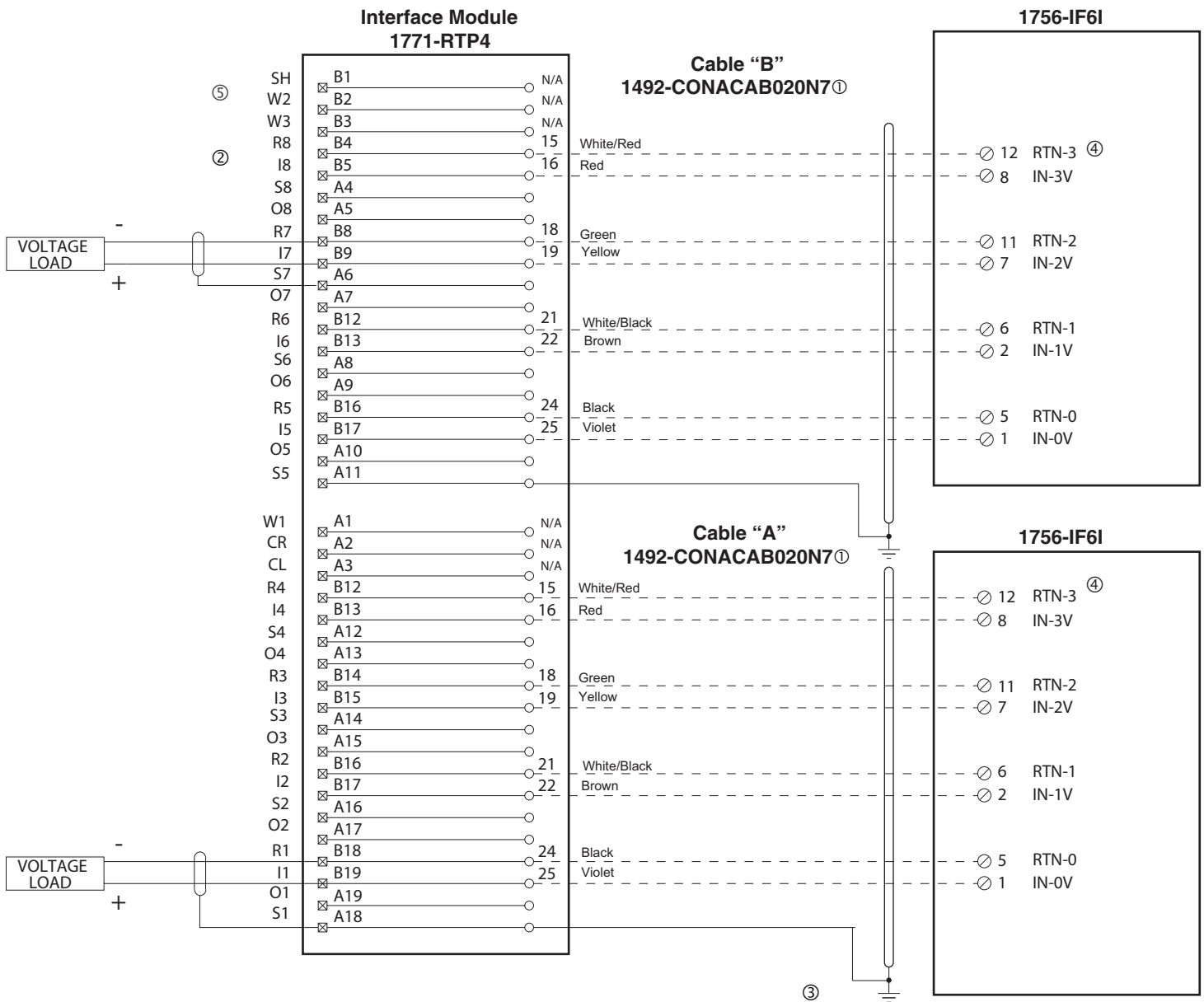

Conversion Module Installation and Application Considerations

- ① Cables are available in 2.0m, or 5.0m
- ② Terminals starting with A are the lower row of terminals, B terminals are the upper row.
- ③ Follow your PLC Analog User Manual for proper shield grounding instructions.
- ④ RTN terminals are internally connected on the 1756-IF6I.
- ⑤ Terminals w1, w2, w3, are spares used for field wire convenience. NOTE: This is only true for module RTP4. The Bul. 1492 cable does not connect to these terminals.

[Reference Doc: 41171-078 (Version 00)]



WARNING

There are several key application considerations and system specifications (bottom of drawing) when using these components (conversion module, cable and input module). Read and understand these considerations before installation.

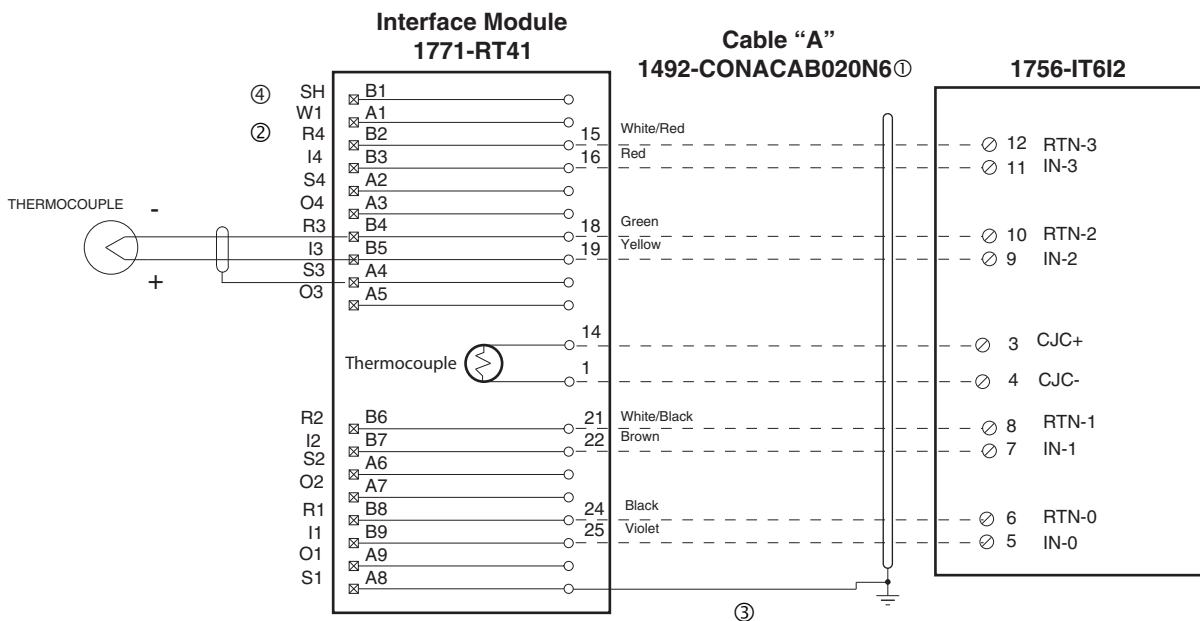
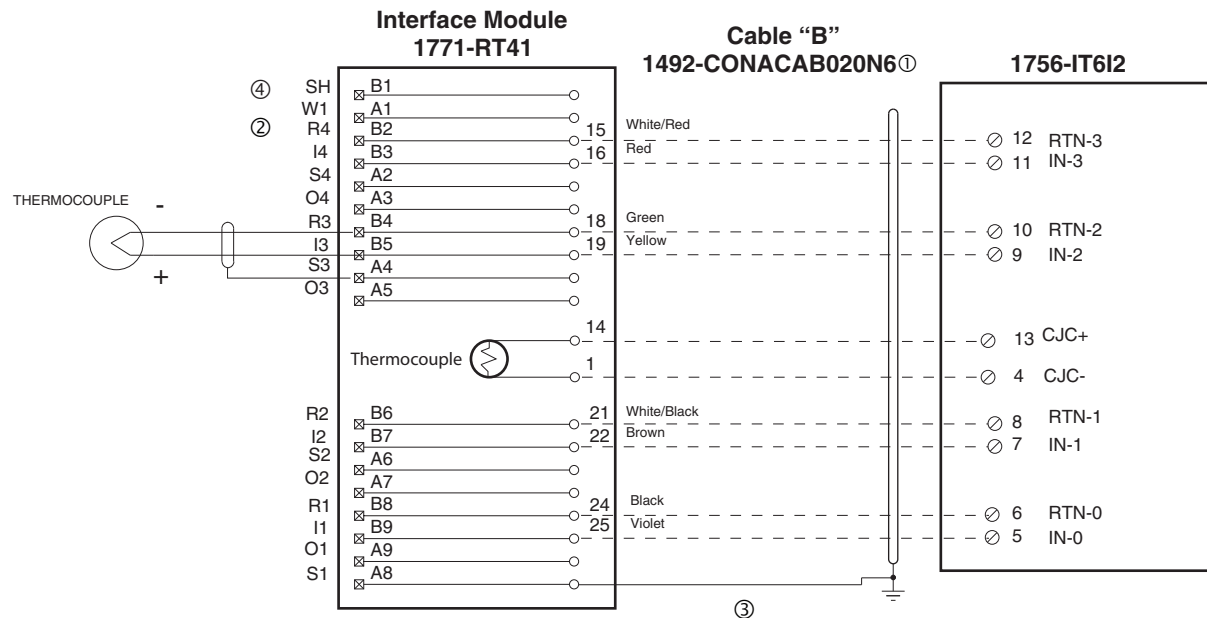

Conversion Module Installation and Application Considerations

- ① Cables are available in 2.0m, or 5.0m
- ② Terminals starting with A are the lower row of terminals, B terminals are the upper row.
- ③ Follow your PLC Analog User Manual for proper shield grounding instructions.
- ④ RTN terminals are internally connected on the 1756-IT6I2.
- ⑤ Terminals w1, w2, w3, are spares used for field wire convenience. NOTE: This is only true for module RT41. The Bul. 1492 cable does not connect to these terminals.
- ⑥ This conversion solution requires replacement of the existing (1) 1771-RTP1 interface module with (2) 1771-RT41 interface modules. Each 1771-RTP1 and RT41 module has there own cold junction compensation thermocouple attached to the interface module.

[Reference Doc: 41171-077 (Version 00)]

Conversion: 1771-NIVR (1) To
1756-IR6I (1) (RTD), 1756-IF6I (1) (Voltage)
Using Existing 1771-RTP4 Interface Module



WARNING

There are several key application considerations and system specifications (bottom of drawing) when using these components (conversion module, cable and input module). Read and understand these considerations before installation.

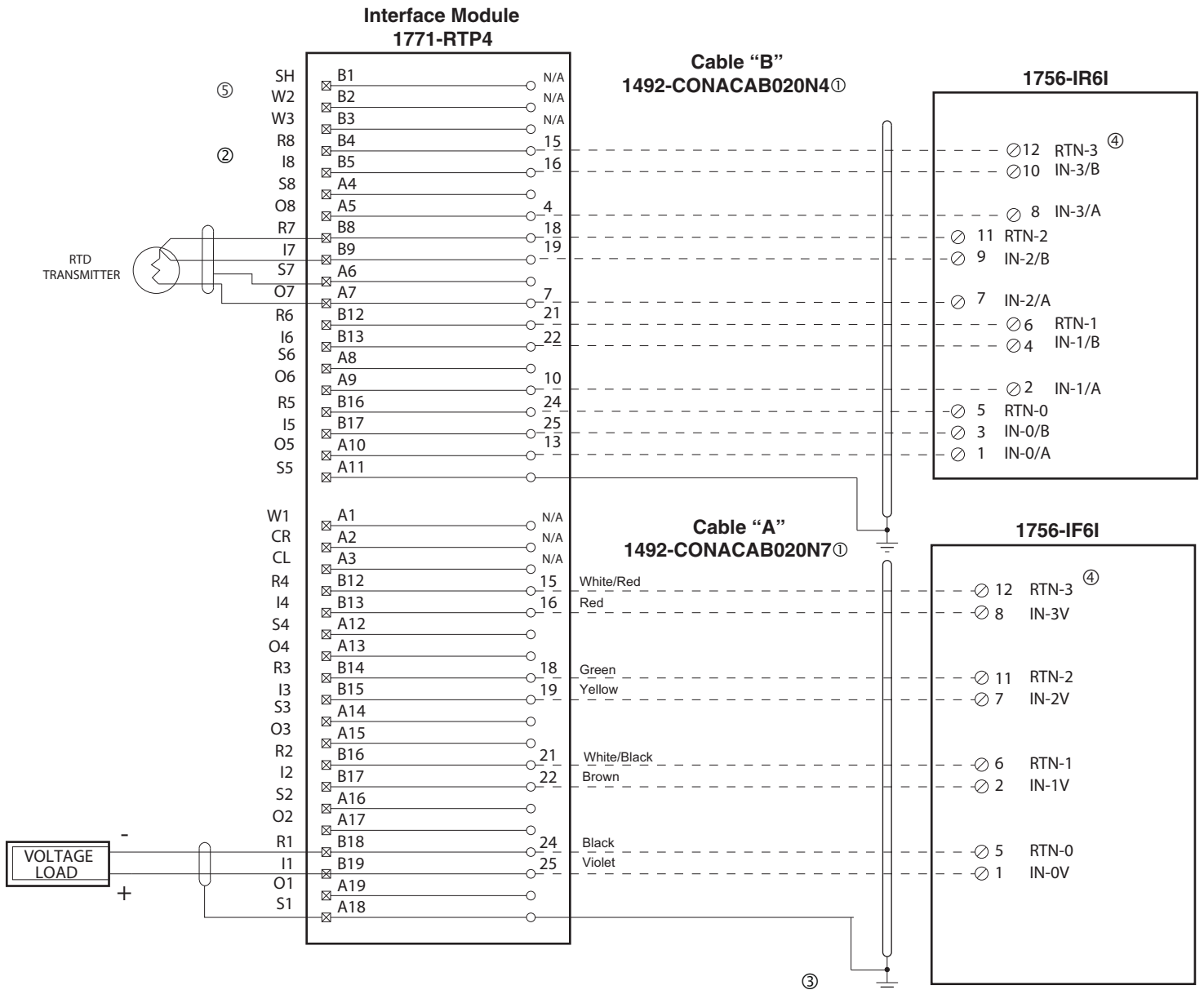

Conversion Module Installation and Application Considerations

- ① Cables are available in 2.0m, or 5.0m
- ② Terminals starting with A are the lower row of terminals, B terminals are the upper row.
- ③ Follow your PLC Analog User Manual for proper shield grounding instructions.
- ④ RTN terminals are internally connected on the 1756-IF6I & IR6I.
- ⑤ Terminals w1, w2, w3, are spares used for field wire convenience. NOTE: This is only true for module RTP4. The Bul. 1492 cable does not connect to these terminals.

[Reference Doc: 41171-082 (Version 00)]

Conversion: 1771-NIVR (1) To
1756-IR6I (1) (RTD), 1756-IF6I (1) (Current)
Using Existing 1771-RTP4 Interface Module



WARNING

There are several key application considerations and system specifications (bottom of drawing) when using these components (conversion module, cable and input module). Read and understand these considerations before installation.

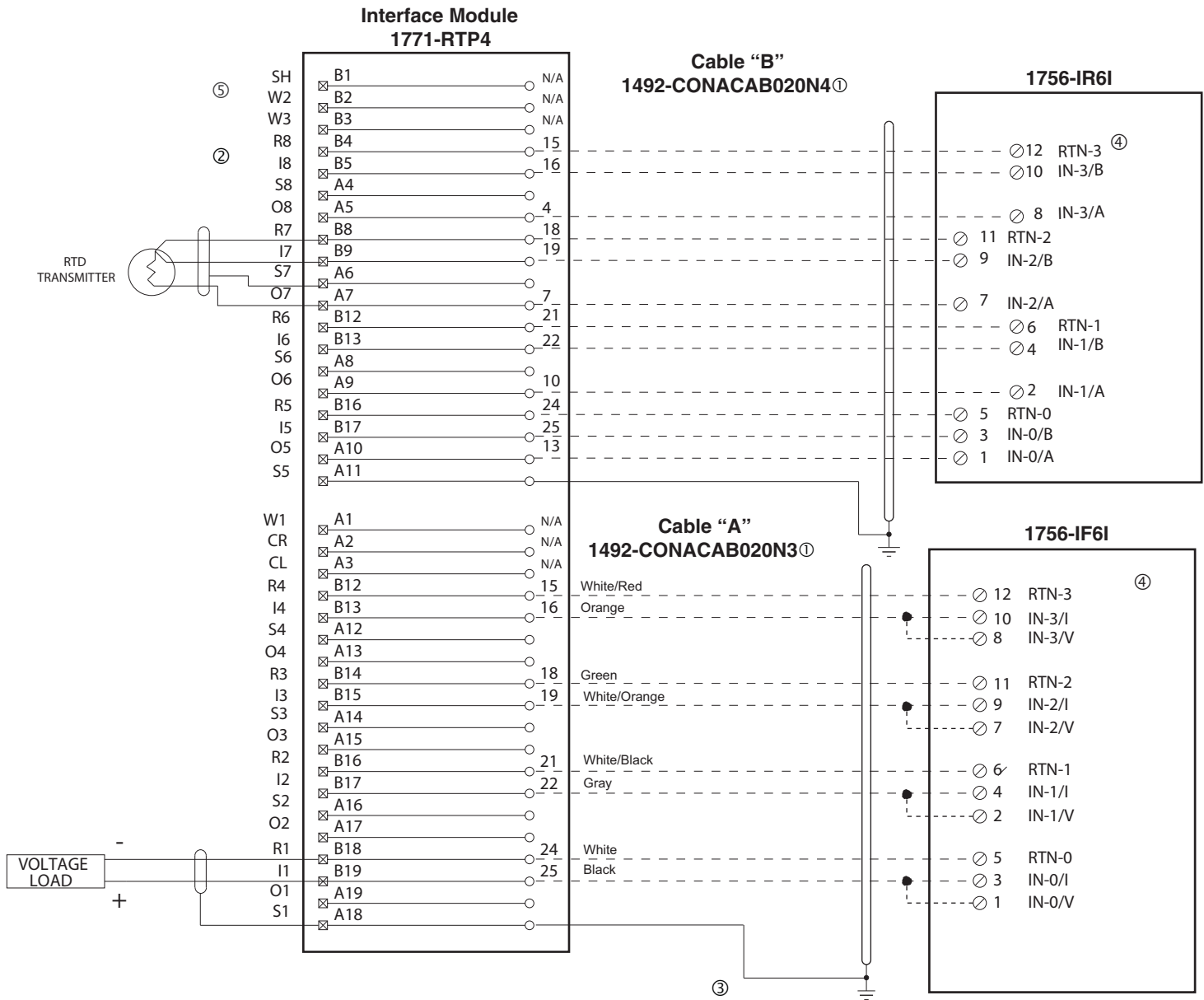

Conversion Module Installation and Application Considerations

- ① Cables are available in 2.0m, or 5.0m
- ② Terminals starting with A are the lower row of terminals, B terminals are the upper row.
- ③ Follow your PLC Analog User Manual for proper shield grounding instructions.
- ④ RTN terminals are internally connected on the 1756-IF6I & IR6I.
- ⑤ Terminals w1, w2, w3, are spares used for field wire convenience. NOTE: This is only true for module RTP4. The Bul. 1492 cable does not connect to these terminals.

[Reference Doc: 41171-083 (Version 00)]



WARNING

There are several key application considerations and system specifications (bottom of drawing) when using these components (conversion module, cable and input module). Read and understand these considerations before installation.

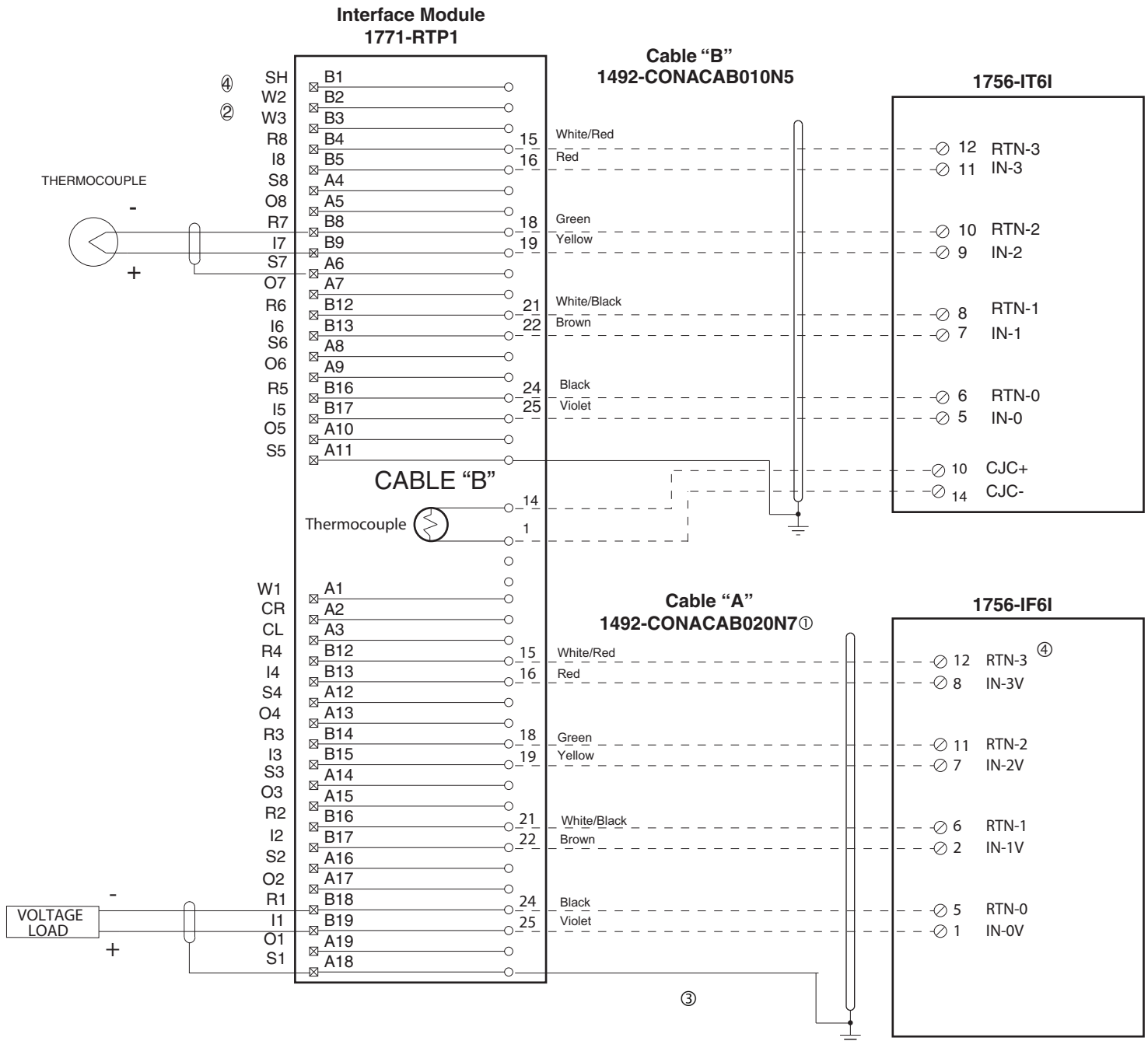

Conversion Module Installation and Application Considerations

- ① Cables are available in 2.0m, or 5.0m
- ② Terminals starting with A are the lower row of terminals, B terminals are the upper row.
- ③ Follow your PLC Analog User Manual for proper shield grounding instructions.
- ④ RTN terminals are internally connected on the 1756-IF6I.
- ⑤ Terminals w1, w2, w3, are spares used for field wire convenience. NOTE: This is only true for module RTP4. The Bul. 1492 cable does not connect to these terminals.

[Reference Doc: 41171-084 (Version 00)]

V. Wiring Diagrams (Continued)

Conversion: 1771-NIVT (1) To 1756-IT6I (1) (Thermocouple), 1756-IF6I (1) (Current) Using Existing 1771-RTP4 Interface Module



WARNING

There are several key application considerations and system specifications (bottom of drawing) when using these components (conversion module, cable and input module). Read and understand these considerations before installation.

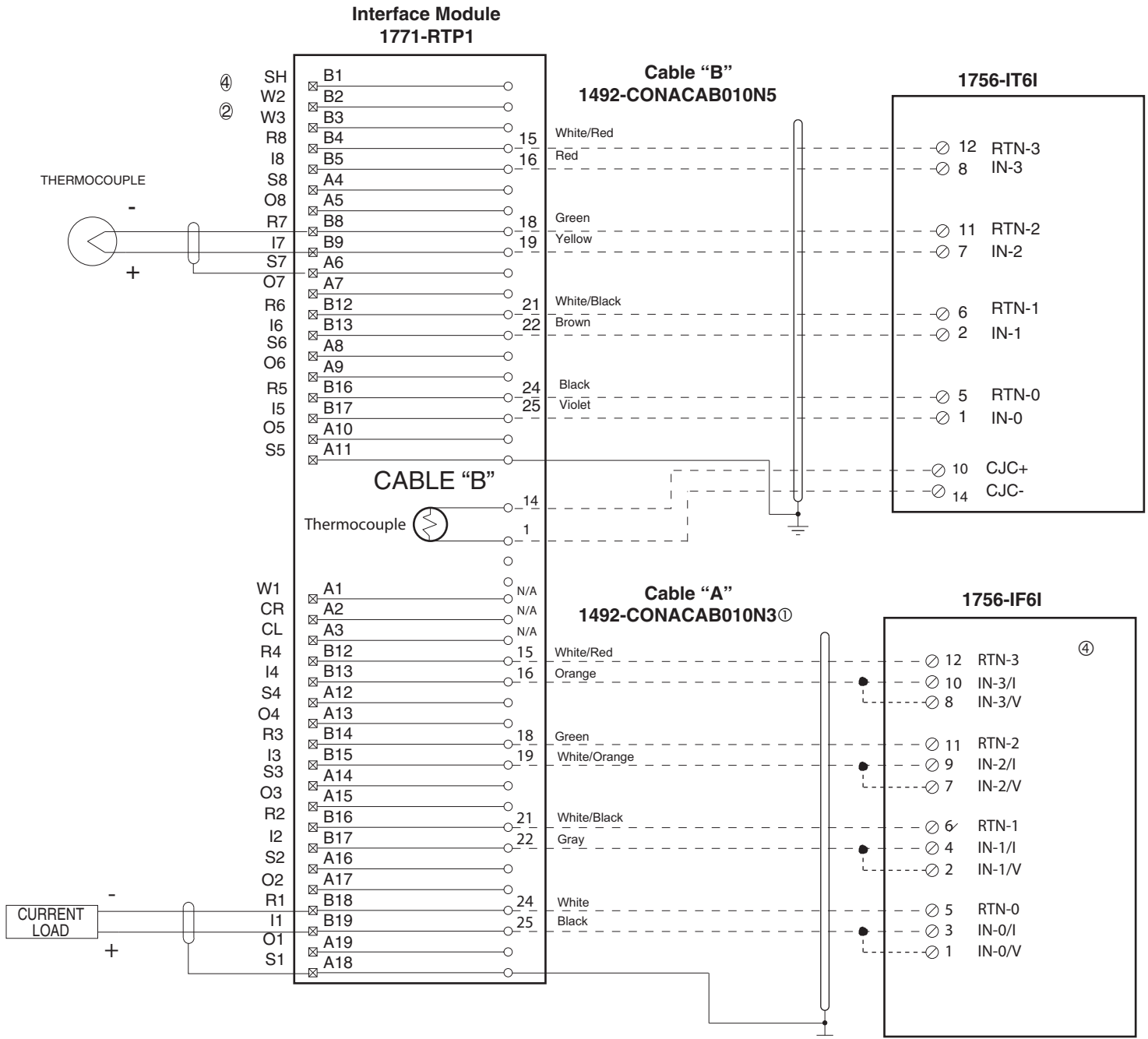

Conversion Module Installation and Application Considerations

- ① Cables are available in 2.0m, or 5.0m
- ② Terminals starting with A are the lower row of terminals, B terminals are the upper row.
- ③ Follow your PLC Analog User Manual for proper shield grounding instructions.
- ④ RTN terminals are internally connected on the 1756-IF6I.
- ⑤ Terminals w1, w2, w3, are spares used for field wire convenience. NOTE: This is only true for module RTP4. The Bul. 1492 cable does not connect to these terminals.

[Reference Doc: 41171-085 (Version 00)]