

# SCSM/SCSL : Surface Canopy Square, Med/Large



project name	type
catalog number	
comments	voltage
approved by	date

22/  
40/55  
watts

1608/  
4285  
lumens

up to  
98  
lpw

5000K  
CCT

## Features

- Classic canopy light appearance powered by advanced LEDs
- Up to 85% savings versus traditional HID sources
- 13 years of maintenance-free operation with LED lifespan of 50,000 hrs
- Eliminates frequent lamp and ballast replacements associated with HID
- Instant-on with no warm up, unlike HID
- Diecast aluminum body construction with impact resistant drop polycarbonate lens
- 4 x 1/2" conduit access hole for through-wiring or photocell capability
- 5 year limited warranty

## Performance

- SCSM-1C - 1,608 lumens @ 22W - replaces 50-100W HID
- SCSL-1C-U - 3,906 lumens @ 40W - replaces 50-175W HID
- SCSL-2C-U - 4,285 lumens @ 55W - replaces 250-400W HID
- Operating temperature: -40°C (-40°F) to 40°C (104°F)
- CCT: 5000K +/- 250K
- CRI: >80
- Input voltage: 120-277V

## Applications

- Strip malls
- Entryways
- Educational facilities
- Plazas
- Canopies
- Eaves
- Public Rest Areas

## Ordering Information

Order Code	Item #	Lm	W	CCT	CRI	Life/Hrs	V	HID Equiv.	DLC
09001	SCSM-1C-U	1,608	22W	5000K	80+	50,000	120-277V	50-100W	
09008	SCSM-1C-347V	1,608	22W	5000K	80+	50,000	347V	50-100W	✓
09002	SCSL-1C-U	3,906	40W	5000K	80+	50,000	120-277V	50-175W	✓
09006	SCSL-1C-347V	3,906	40W	5000K	80+	50,000	347V	50-175W	✓
09003	SCSL-2C-U	4,285	55W	5000K	80+	50,000	120-277V	250-400W	
09007	SCSL-2C-347V	4,285	55W	5000K	80+	50,000	347V	250-400W	

✓DesignLights Consortium® Qualified

## Accessories (Sold Separately)

Order Code	Litespan Part #	Description
08738	PCB1	Photocontrol, Button Type 120V
08739	PCB2	Photocontrol, Button Type 277V



SCSM/SCSL : Surface Canopy Square, Med/Large

Dimensions

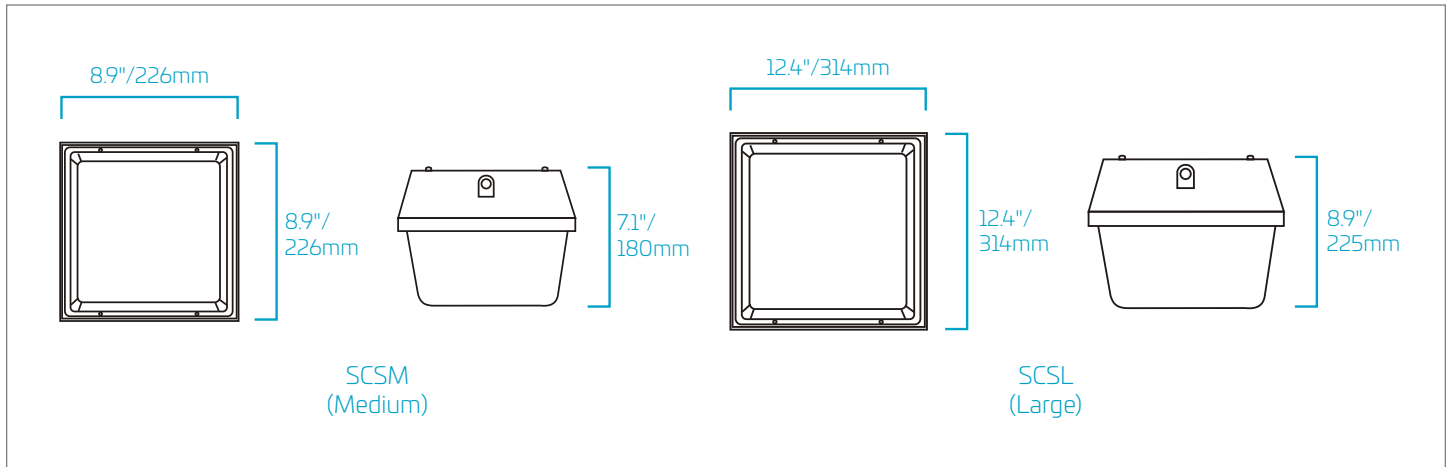

Accessories (Sold Separately)

Order Code	Litespan Part #	Description
<b>09849</b>	FHSCP-UNV-5WL	5W Emergency Battery Backup
<b>09851</b>	FHSCP-UNV-7.8WL	7.8W Emergency Battery Backup
<b>09850</b>	FHSCP-UNV-10.7WL	10.7W Emergency Battery Backup
<b>09852</b>	FHSCP-UNV-13.7WL	13.7W Emergency Battery Backup
<b>09854</b>	FHSCP-UNV-17WL	17W Emergency Battery Backup

watch > like > follow

