

Catalog Number • Numéro de Catalogue • Número de Catálogo: DW-100-24

Country of Origin: Made in China • Pays d'origine: Fabriqué en Chine • País de origen: Hecho en China

DESCRIPTION AND OPERATION

The DW-100-24 Dual Technology Low Voltage Wall Switch sensor combines advanced passive infrared (PIR) and ultrasonic technologies into one unit. The combined technologies help to eliminate false triggering even in difficult applications.

Selectable operating modes allow the sensor to turn a load **ON**, and hold it **ON** as long as either or both technologies detect occupancy. After no movement is detected for the selected time delay, the lights switch **OFF**. A “walk-through” mode can turn lights **OFF** after only 3 minutes, if no activity is detected after 30 seconds following an occupancy detection.

The DW-100-24 has one relay and one **ON/OFF** button. Pressing the button toggles the state of the relay.

The DW-100-24 also contains a light level sensor. If adequate daylight is present, the sensor holds the load **OFF** until light levels drop, even if the area is occupied. Users can override this function by pressing the **ON/OFF** button. See Light Level Adjustment.

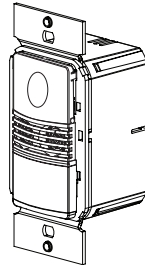

SPECIFICATIONS

Voltage	18-24VDC, 24VAC or Half-wave rectified AC
Current Consumption	35mA
Power Supply	Wattstopper Power Packs
Isolated Relay Rating	1A @30VDC/VAC
Time Delay Adjustment	5 to 30 minutes
Walk-Through Mode	3 minutes if no activity after 30 sec.
Test Mode....	5 sec. for 10 min. with DIP Switch setting
PIR Adjustment.....	High or Low (DIP Switch)
Ultrasonic Adjustment.....	Minimum to Maximum (trimpot), Off
Frequency.....	40kHz
Light Level Adjustment	8fc to 180+fc
Alerts	Selectable Audible
US Patent:	6617560

Turning ON the Load (ON Mode)

The DW-100-24 can be programmed for either **Auto ON** or **Manual ON** mode. In either mode, the load can be turned **ON** or **OFF** using the **ON/OFF** button.

Manual ON DIP#8 ON	With the ON Mode DIP Switch in the ON position, the occupant must press the ON/OFF button to turn ON the load. The sensor keeps the load ON until no motion is detected for the selected time delay. There is a 30 second re-trigger delay. If occupancy is detected during the delay, the sensor turns the load back ON . After the re-trigger delay elapses the ON/OFF button must be pressed to turn ON the load.
Auto ON DIP#8 OFF	With the ON Mode DIP Switch in the OFF position, the load turns ON and OFF automatically based on occupancy. If the load is turned OFF manually, Presentation Mode operation applies. This prevents the load from turning ON automatically after it was deliberately turned OFF . Pressing the button to turn lights ON returns the sensor to Auto ON mode.

Presentation Mode

This is a feature of the **Auto ON** mode. When the relay is manually turned **OFF** the DW holds the lights **OFF** until no motion has been detected for the duration of the Time Delay. With subsequent occupancy, the DW turns the load **ON**.

Time Delays

The DW-100-24 holds the load **ON** until no motion is detected for the selected time delay. Select the time delay using DIP Switch settings. In the DW-200, both relays use the same delay.

NOTE: Shaded cells below indicate default operation and switch setting.

Test/20 min (DIP#1 & 2 OFF)	A Test Mode with a short time delay of five seconds is set when DIP Switches 1 & 2 are OFF . It cancels automatically after ten minutes, or when you set a fixed time delay. When the Test Mode times out, the sensor will assume a 20 minute time delay. To restart Test Mode, change the time delay setting to any fixed amount and then return it to the Test setting.
Fixed Time Delay (DIP#1 ON, & 2 OFF)	Time delays of 5, 15 (default), or 30 minutes are available. See DIP SWITCH SETTINGS for information.

Walk-Through

The Walk-Through mode shortens the time delay to reduce the amount of time the load is **ON** after a brief moment of occupancy, such

as returning to an office to pick up a forgotten item then immediately exiting.

Walk-Through Mode (DIP #3 ON)	The DW sensor turns the load OFF three minutes after the area is initially occupied, if no motion is detected after the first 30 seconds. If motion continues beyond the first 30 seconds, the set time delay applies.
No Walk-Through (DIP #3 OFF)	Walk-Through mode disabled.

PIR Sensitivity Adjustment

The DW-100-24 constantly monitors the controlled environment and automatically adjusts the PIR to avoid common ambient conditions that can cause false detections, while providing maximum coverage.

High (DIP #4 OFF)	Default setting. Suitable for most applications.
Low, 50% (DIP #4 ON)	Reduces sensitivity by approximately 50%. Useful in cases where the PIR is detecting movement outside of the desired area (also consider masking the lens) and where heat sources cause unnecessary activation.

Alerts

The DW can provide audible alerts as a warning before the load turns **OFF**.

Audible Alerts (DIP #7 ON)	Unit will beep at one minute, at 30 seconds, and at 10 seconds before turning OFF load. When Walk-Through is active, the unit beeps three times at 10 seconds before the load goes OFF .
No Audible Alerts (DIP #7 OFF)	No audible warnings provided.

Trigger Mode

The DW sensor has four occupancy trigger options, set with DIP Switches 5 and 6. Determine the appropriate option using the Trigger matrix.

In the Trigger Mode DIP Switch setting table, in order to deem the area occupied:

- **Both** requires motion detection by the PIR and the Ultrasonic.
- **Either** requires motion detection by only one technology.
- **PIR** requires motion detection by the PIR.

Initial Occupancy: The method that activates a change from "Standby" (area unoccupied and load **OFF**) to "Occupied" (area occupied and load may turn **ON**).

Maintain Occupancy: The method indicating that the area is still occupied and the lights should remain **ON**.

Re-trigger: In **Auto On Mode**, after the load turns **OFF**, detection by the selected technology within the number of seconds indicated turns the lights back **ON**. If the load was turned **ON** with the **ON/OFF** button, the re-trigger time is 30 seconds.

Trigger Mode	Initial Occupancy	Maintain Occupancy	Re-trigger	DIP Switch	
				5	6
Standard	Both	Either	Either	↓	↓
Option A	PIR	Either	Either	↓	↑
Option B	PIR	PIR	PIR	↑	↓
Option C	Both	Both	Both	↑	↑

↑ = ON ↓ = OFF

COVERAGE PATTERNS

Coverage testing has been performed according to the NEMA WD 7 guideline. For best performance, use in spaces not larger than 18' x 15'.

PIR Sensor

The sensor has a two-tiered, multi-cell viewing Fresnel lens with 180 degree field of view. The red LED on the sensor flashes when the PIR detects motion.

Masking the lens

Opaque adhesive tape is supplied so that sections of the PIR sensor's view can be masked. You can eliminate coverage in unwanted areas. Since masking removes bands of coverage, take this into account when troubleshooting coverage problems.

Ultrasonic Sensor

The sensor has two ultrasonic transceivers operating at 40kHz. Detection sensitivity can be adjusted using the trimpot under the **ON/OFF** buttons.

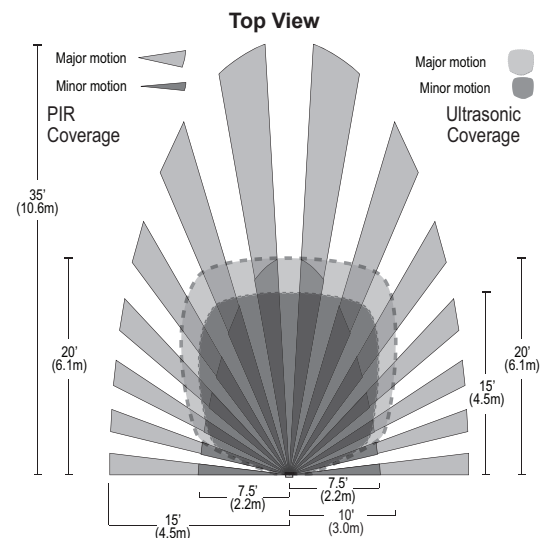
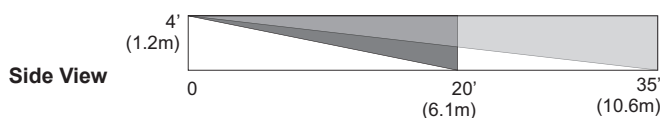

INSTALLATION

1. Install the power pack according to its instructions.
2. Connect the power pack wires to the sensor as follows:
RED wire (+24VDC) to the +24V IN terminal on the sensor.
BLACK wire (Return) to common (COMM.) terminal on the sensor.
BLUE wire to control output (CTRL. OUT) terminal on the sensor.
3. Wire the Isolated Relay. The Isolated Relay is rated for 1A @ 30VAC/VDC. Connect the wires necessary to the application that requires this output:
 - Normally Closed (N.C.) - Open when occupancy is detected.
 - Relay Common (must be used for proper operation)
 - Normally Open (N.O.) - Closed when occupancy is detected.
 The bottom terminal on the sensor is not used.
4. Turn the power **ON**.
5. Test and adjust the sensor if necessary.
6. Install industry standard decorator wall switch cover plate (not included).

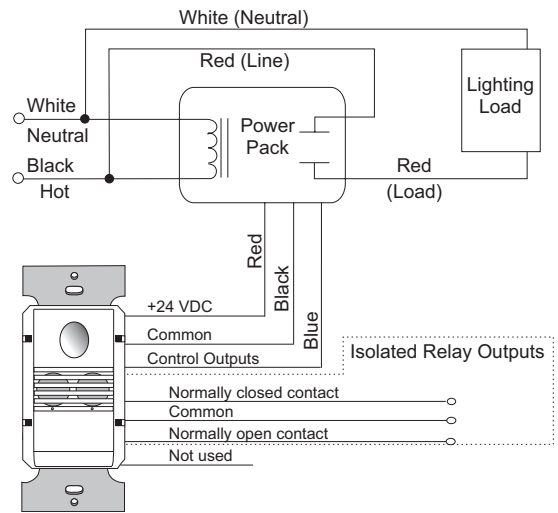

DIP SWITCH SETTINGS

Time Delay	1	2
Test/20 min	↓	↓
5 minutes	↓	↑
15 minutes	↑	↓
30 minutes	↑	↑

Walk-Through	3
Enabled	↑
Disabled	↓

PIR Sensitivity	4
Low, 50%	↑
High	↓

Audible Alert	7
Enabled	↑
Disabled	↓

ON Mode	8
Manual On	↑
Auto On	↓

Trigger Mode	5	6
Standard	Both	Either
Option A	PIR	Either
Option B	PIR	PIR
Option C	Both	Both

Switch 9 is not used
 ↑ = ON ↓ = OFF
 ◀ = Factory Setting

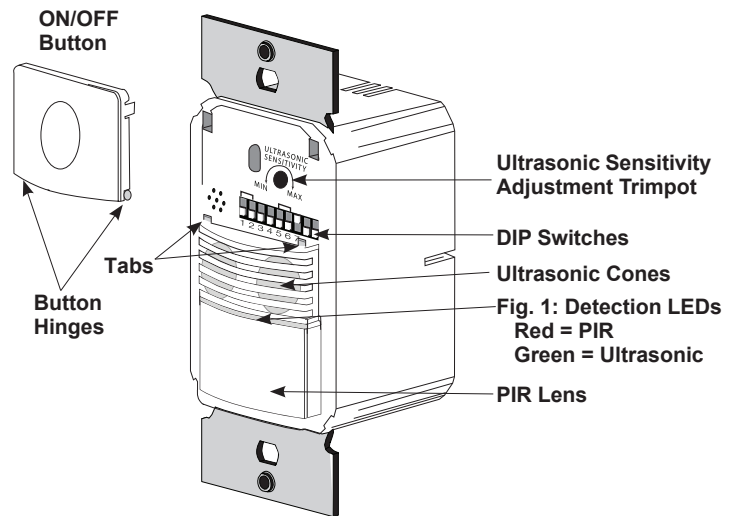

ADJUSTMENTS

Sensor Adjustment

Remove the wall plate. Remove the button cap by firmly squeezing together the top sides of the button assembly. Gently pull it away from the unit.

When the adjustments are completed, replace the button cap by inserting its hinges into the tabs on the main unit and then squeeze the top of the button while pressing it into the unit. Reinstall the cover plate.

Light Level Adjustment

The light level can be set with loads **ON** or **OFF**. To enable light level control and set the threshold:

1. Make sure the room is lit appropriately.
2. Put the sensor into TEST mode. You have 5 minutes to complete the procedure.
3. Press and hold the **ON/OFF** button for 3 seconds, until you hear a beep.
4. Step away from the sensor. After 25 seconds a beep sounds, indicating that the threshold level is set. This threshold is retained, even if power is lost, until it is re-set or disabled.

To disable light level control, press and hold the **ON/OFF** button for 7 seconds, until a double beep tone sounds.

Reset to Default

Use the DIP Switch Settings tables on the previous page to return features to factory settings. To reset the DW press and hold the **ON/OFF** button for 10 seconds, until a triple beep sounds. This resets the sensor and disables light level control (the brightest ambient light will not hold the light **OFF**).

Service Mode

To enter service mode set the ultrasonic trimpot to MIN (fully counter-clockwise).

TROUBLESHOOTING

Lights do not turn ON with motion (LED does flash)

1. Press and release each button to make sure that the correct lights come **ON**. If the lights do NOT turn **ON**, check wire connections, especially the Load connection. If the lights turn **ON**, verify that the correct On Mode is selected in DIP Switches 8 and 9.
2. Check to see if light level control is enabled: cover the sensor lens with your hand. If the lights come **ON**, adjust the light level setting.
3. If lights still do not turn **ON**, call 800.879.8585 for technical support.

Lights do not turn ON with motion (LED does not flash)

1. Press and release each button. Make sure that the correct lights come **ON**. If the lights turn **ON**, set PIR and Ultrasonic Sensitivity to High.
2. Check the wire connections, in particular, the Neutral and Line connections. Verify that connections are tightly secured.
3. If lights still do not turn **ON**, call 800.879.8585 for technical support.

Lights do not turn OFF

1. There can be up to a 30 minute time delay after the last motion is detected. To verify proper operation, set DIP Switch 1 to **ON**, then reset switches 1 and 2 to **OFF** to start Test Mode. Move out of view of the sensor. The lights should turn **OFF** in approximately 5 seconds.
2. Verify that the sensor is mounted at least six feet (2 meters) away from any heating/ventilating/air conditioning device that may cause false detection. Verify that there is no significant heat source (such as a high wattage light bulb) mounted near the sensor.
3. Verify that the trimpot is not pointing at "Service" (red LED **ON**). If so, rotate the trimpot to its middle setting (pointing up). The Service setting allows users to operate the sensor as a service switch in the unlikely event of a failure.
4. If the lights still do not turn **OFF**, call 800.879.8585 for technical support.

Sensing motion outside desired areas

1. Select PIR Sensitivity — Low (DIP Switch 4 = **ON**) if necessary.
2. Mask the PIR sensor's lens to eliminate unwanted coverage area.
3. Adjust the Ultrasonic Sensitivity. Rotate trimpot counterclockwise to reduce sensitivity.

Red LED is lit all the time and the sensor features don't work.

1. Check the Ultrasonic trimpot. If it is set at fully counter-clockwise (MIN) the unit is in Service Mode. Set the trimpot to a mid-range position.
2. If resetting the trimpot does not clear the LED call technical support.

COVER PLATES

Wattstopper DW series wall switches fit behind industry standard decorator-style switch cover plates. Cover plates are not included.

Units come in the following colors, which are indicated by the final suffix of the catalog number (shown here in parentheses):

White (-W), Light Almond (-LA), Ivory (-I), Grey (-G), Black (-B).

WARRANTY INFORMATION

Wattstopper warrants its products to be free of defects in materials and workmanship for a period of five (5) years. There are no obligations or liabilities on the part of Wattstopper for consequential damages arising out of, or in connection with, the use or performance of this product or other indirect damages with respect to loss of property, revenue or profit, or cost of removal, installation or reinstallation.

INFORMATIONS RELATIVES À LA GARANTIE

Wattstopper garantit que ses produits sont exempts de défauts de matériaux et de fabrication pour une période de cinq (5) ans. Wattstopper ne peut être tenu responsable de tout dommage consécutif causé par ou lié à l'utilisation ou à la performance de ce produit ou tout autre dommage indirect lié à la perte de propriété, de revenus, ou de profits, ou aux coûts d'enlèvement, d'installation ou de réinstallation.

INFORMACIÓN DE LA GARANTÍA

Wattstopper garantiza que sus productos están libres de defectos en materiales y mano de obra por un período de cinco (5) años. No existen obligaciones ni responsabilidades por parte de Wattstopper por daños consecuentes que se deriven o estén relacionados con el uso o el rendimiento de este producto u otros daños indirectos con respecto a la pérdida de propiedad, renta o ganancias, o al costo de extracción, instalación o reinstalación.