

Bullyte (CUL16) Specification Sheet

Project Name:

Location:

MFG: Philips Hadco

Fixture Type:

Catalog No.:

Qty:

Ordering Guide

Example: CUL16 S7 _

Product Code	CUL16	Bullyte
Mounting	S7	Mounting Stake
Finish	_	Natural Copper

* This model is intended for up lighting only.

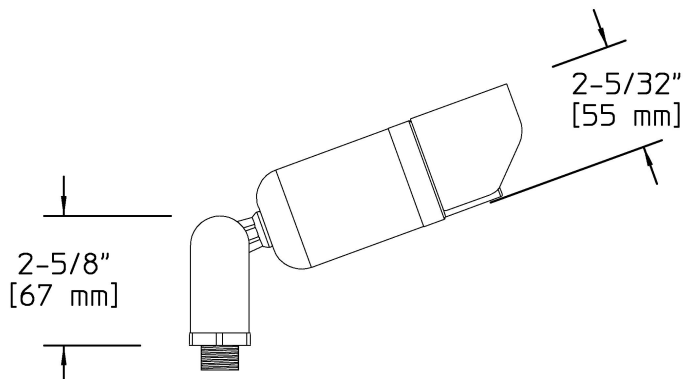

Specifications

HOUSING:

Fully-adjustable natural brass swivel arm and brass locknut. 1/2" NPS male threads to screw onto accessory mounting stake or junction box, sold separately. Fasteners are 300 series stainless steel. Deep-drawn solid copper. Fully rotatable shroud, deep-drawn solid copper.

FINISH:

Natural Copper is bright polished, untreated copper. Color will age naturally to a fine dark copper patina.

LAMPING:

35W maximum MR16 bi-pin lamp. 20W MR16 lamp included. Lower wattage lamps are acceptable.

ELECTRICAL ASSEMBLY:

Bi-pin socket type (G4) with 250° C high temperature teflon coated wire leads. Stainless steel retention clip affixed to socket to securely hold lamp in place. 12 Volt fixture is pre-wired with 3-ft pigtail of 18-2 AWG, 105° C, SPT-1W wire. Low voltage quick connector, catalog #LVC3 included for easy hook-up to the low voltage supply cable, not included. 12 Volt system requires remote transformer, not included.

WARRANTY:

Ten-year limited warranty.

CERTIFICATIONS:

ETL listed to U.S. safety standards for wet locations. cETL listed to Canadian safety standards for wet locations. Manufactured to ISO 9001:2008 Standards.

Width:

2 5/32" (55mm)

Length:

7 13/64" (183mm)

Max. Weight:

1.8 lb