

Mercmaster™ III Low Profile Compact Fluorescent Luminaires

Enclosed and Gasketed. For Hazardous and Wet Locations

Compact Fluorescent listed for simultaneous exposure to combustible dusts and flammable gases or vapors.

*Class I, Division 2, Groups A, B, C, D
Class I, Zone 2, AEx nA nR IIC (Z2)
Class I, Zone 2, Ex nR IIC (Z) vA*

*Class II, Division 1 and 2, Groups E, F, G
Class III
Simultaneous Exposure (Class I, Division 2/
Class II, Division 1)*

*Fixtures Outside Type (Salt Water)
Type 4X
IP66*

Applications

- Enclosed and gasketed fixtures suitable for use in marine and wet locations, and in a wide range of industrial, chemical processing and other areas where flammable gases and vapors or combustible dusts are present under conditions defined by the National Electrical Code as Class I, Division 2; Class II, Division 1 and 2; and Class III. The method of protection for the Zone 2 Mercmaster is AEx nA nR – Restricted Breathing/ Nonsparking.
- For use in areas of low clearance, low ceiling heights or where fixture weights must be minimized.
- Suited for use in non-hazardous locations where severe weather conditions, excessive moisture, dirt, dust or corrosive atmospheres are present.
- Typical applications include oil refineries, pulp and paper mills, chemical plants, food-processing areas, inspection facilities, foundries, power plants, storage areas, waste and sewage treatment, parking garages, and other areas where dust, water, dirt and rough usage are a problem.

Features

- Energy-efficient, compact fluorescent light sources possess superior lamp efficiency.
- Fluorescent provides long lamp life, thereby reducing relamping costs.
- "Instant on" nature of this electronically ballasted fluorescent eliminates the possibility of an extended blackout due to a momentary power dip.
- High efficacies (up to 75 lumens per Watt) offer a desirable low-glare/instant-on alternative to low wattage HID sources.
- High output under widely varying conditions: Greater than 90% of rated lumens in ambient temperatures from 23 °F to 130 °F / -5 °C to 54 °C.
- Excellent color rendering (82 CRI) makes it the best choice for food processing and inspection facilities.
- A wide variety of lamp wattages: 26 W, 32 W, 42 W, 52 W, 64 W, 84 W.
- Electronic ballast permits low operating costs with power factor greater than 99%. Also allows flicker-free starting.
- Cold weather starting to a minimum temperature of 0°F/ -18°C.
- Fixtures are available for operation from an external 125 Vdc source.
- Compact, light-weight low profile design creates ease of installation and maintenance.
- Modular design, with multiple mounting hoods, optics and reflectors, permits a wide array of fixtures to meet installation and lighting needs.
- Body gaskets and optic gaskets are high temperature silicone O-Rings that provide superior sealing.
- Mounting hoods have a high hinge for added safety during installation and servicing.
- Choice of heat-resistant prismatic glass refractor (NEMA I, III or V), heat-resistant clear globes, color globes or polymeric refractors (NEMA II, III, IV or V). (Polymeric refractors are not listed for Zone 2.)



Pendant Mount Fixture
with Glass Globe

Ceiling Mount Fixture with
Prismatic Glass Refractor

Standard Materials

- Standard dome or 30° angle reflectors: highly reflective fiberglass reinforced white polyester to provide strength, corrosion resistance and excellent photometrics
- Fixture housing, mounting hoods, and guards: die-cast, copperfree (4/10 of 1% max.) aluminum with epoxy finish for corrosion resistance
- Exposed hardware: stainless steel. Latch assemblies have stainless steel bolt and captive nut; reflectors and guards attach with stainless steel screws threading into stainless steel inserts
- Globes and glass refractors: heat-resistant prismatic glass
- Polymeric refractor: spun aluminum reflector and a lens made of an engineered thermoplastic

Standard Finishes

- Epoxy powder coat finish electrostatically applied for complete, uniform surface protection

Options

- Fuse can be field installed. Kits include fuse block, wire connectors and screws for attachment to mounting hood.
 - Fixtures with fuses do not comply with UL 1598A for marine listing
 - Canadian Electrical Code does NOT allow fusing in hazardous locations vA
- Guards with gray epoxy painted to match fixtures, supplied with stainless steel screws. Add suffix **-G**.
- Reflectors are available as standard dome and 30° angle polyester. Order separately.

Certifications and Compliances

- UL Standard: UL 1598, UL 1598A, UL 844, UL 60079-0, UL 60079-15
- UL Listed: E10444
- CSA Standard: C22.2 No. 250, C22.2 No. 137, CAN E60079-0, CAN E60079-15
- CSA Certified: 025428

vA CSA Certification Only.

Mercmaster™ III Low Profile Compact Fluorescent Luminaires

Enclosed and Gasketed. For Hazardous and Wet Locations

Class I, Division 2, Groups A, B, C, D
Class I, Zone 2, AEx nA nR IIC (Z2)
Class I, Zone 2, Ex nR IIC (Z) ¹

Class II, Division 1 and 2, Groups E, F, G
Class III
Simultaneous Exposure (Class I, Division 2/
Class II, Division 1)

Fixtures Outside Type (Salt Water)
Type 4X
IP66

Order using catalog numbering guide below or select catalog number from tables on following pages.

Catalog Numbering Guide For Zone 2 Mercmaster III Compact Fluorescent Luminaires

<p>ML</p> <p>Series: ML - Mercmaster III Low Profile</p>	<p>A</p> <p>Mounting Hood: A - Pendant (Rigid or Flexible) C - Ceiling D - Pendant Cone R - 90° Stanchion S - 25° Stanchion W - Wall</p>	<p>F</p> <p>Lamp Type: F - Fluorescent</p>	<p>84</p> <p>Wattage: 26 - One 26 Watt PL-T 32 - One 32 Watt PL-T 42 - One 42 Watt PL-T 52 - Two 26 Watt PL-T 57 - One 57 Watt PL-T ¹ 64 - Two 32 Watt PL-T 84 - Two 42 Watt PL-T 114 - Two 57 Watt PL-T ¹</p>	<p>2</p> <p>Hub Size: 2 - 3/4" NPT 3 - 1" NPT 4 - 1-1/4" NPT Stanchion 5 - 1-1/2" NPT Stanchion</p>	<p>G2</p> <p>Optical Assembly: ① G2 - VPGL2HR Globe (not for 57, 114 Watt) G4 - VPGL4HR Globe (57, 114 Watt only) ¹ J1 - NEMA I Glass Refractor J3 - NEMA III Glass Refractor J5 - NEMA V Glass Refractor P2 - NEMA II Polymeric Refractor P3 - NEMA III Polymeric Refractor P4 - NEMA IV Polymeric Refractor P5 - NEMA V Polymeric Refractor</p>	<p>G</p> <p>Guard Options: G - Cast Guard (Glass Refractor & Globe only) N - No Guard</p>	<p>BU</p> <p>Voltage: BU - 120 to 277 V, 50/60 Hz and 125 Vdc A5 - 347 V, 60 Hz ¹</p>	<p>L</p> <p>Lamp Options: L - Lamp(s) included Blank - Lamp(s) excluded</p>	<p>Z2</p> <p>Suffix: DP - Safety Cable SC - Safety Chain Z2 - Zone 2 Suffix (Required for AEx nA nR rating) B - Battery Back-up ② ¹ (42 W max.) C - Safety Cable ¹ F - Fused Mtg. Hood ③ ¹ (Non-Haz. Loc. only) P - Non-Haz. Photocell (Specify Voltage) ¹ Q - Division 2 Haz. Photocell (Specify Voltage) ¹ T - Terminal Blocks ¹ V - Vibration Protection ¹ X - Appledapter ② Mounting Hood Adapter ¹ Z - Zone 2 suffix (required for Ex nR) ¹</p>
---	---	---	---	--	---	--	---	--	--

Lighting

LIGHTING: ENCLOSED AND GASKETED – AREA – FLUORESCENT

① Polymeric refractors suitable for Class II, Groups F & G; NEMA 4X; and Marine Type Electric Fixture Outside Type (Salt Water) only. Reflectors ordered separately (for use with globe fixtures only): Standard Dome: KR2-ST 30-degree Angle: KR2-AN

② Appledapter is available for use with the pendant, ceiling and angled stanchion mounting only.

③ Canadian Electrical Code does NOT allow fusing in hazardous locations ¹.

④ Provides a minimum 90 minute back-up power supply in the case of a power loss. Will keep one lamp lit at approximately 50% of its full output (42 W maximum) ¹.

¹ CSA Certification only.

Mercmaster™ III Low Profile Compact Fluorescent Luminaire Thermal Performance

Class I, Division 2; Class II, Division 1; Simultaneous Exposure to Hazardous Conditions

Temperature identification numbers of Mercmaster III Low Profile Fluorescent Fixtures

Class I, Division 2, Groups A, B, C, D
Class I, Zone 2, AEx nA nR IIC (Z2)
Class I, Zone 2, Ex nR IIC (Z) [Ⓢ]

Class II, Division 1 and 2, Groups E, F, G
Class III
Simultaneous Exposure (Class I, Division 2/
Class II, Division 1)

Fixtures Outside Type (Salt Water)
Type 4X
IP66

Lamp Watts	Ambient Temp (°F/°C) ①	Class I, Division 2				Class II, Division 1 Groups E, F and G ②				Simultaneous Exposure (Class I, Div 2 and Class II, Division 1)			
		Globe	Globe & Reflector	Glass Refractor	Polymeric Refractor	Globe	Globe & Reflector	Glass Refractor	Polymeric Refractor	Globe	Globe & Reflector	Glass Refractor	Polymeric Refractor
26	104/40	T3	T3	T3	—	T5	T5	T5	T6	T3	T3	T3	—
32	104/40	T3	T3	T3	—	T5	T5	T5	T6	T3	T3	T3	—
42	104/40	T3	T3	T3	—	T5	T5	T5	T6	T3	T3	T3	—
52	104/40	T2D	T2D	T3	—	T4A	T4A	T4A	T6	T2C	T2C	T2C	—
52	151/55	T2C	T2C	T2C	—	T4	T4	T4	—	T2C	T2C	T2C	—
57 [Ⓢ]	104/40	T2D	T2D	T3	—	T4A	T4A	T4A	T6	—	—	—	—
64	104/40	T2D	T2D	T3	—	T4A	T4A	T4A	T6	T2C	T2C	T2C	—
64	151/55	T2C	T2C	T2C	—	T4	T4	T4	—	—	—	—	—
84	104/40	T2C	T2C	T2D	—	T3C	T3C	T3C	T6	T2B	T2B	T2B	—
114 [Ⓢ]	104/40	T2C	T2C	T2D	—	T3C	T3C	T3C	T6	—	—	—	—

“T” Numbers Represent the Maximum Lamp Temperature for Class I, Division 2 Locations and Maximum Surface Temperature Under Dust Blanket for Class II, Division 1 Locations.

“T” Number	T1	350	325	T2	T2A	T2B	T2C	T2D	T3	T3A	T3B	T3C	T4	T4A	T5	T6
Temp. Range (°F)	664-842	619-662	574-617	538-572	502-536	448-500	421-446	394-419	358-392	331-356	322-329	277-320	250-275	214-248	187-212	185
Temp. Range (°C)	351-450	326-350	301-325	281-300	261-280	231-260	216-230	201-215	181-200	166-180	161-165	136-160	121-135	101-120	86-100	85

Lamp Watts	Supply Wire Temp. (°F/°C)	Ambient Temp. (°F/°C)	Class I, Zone 2, AEx nA nR — Ex nR		
			Globe	Globe & Reflector	Refractor
26	167/75	104/40	T5	T5	T6
32	167/75	104/40	T5	T5	T6
42	167/75	104/40	T5	T5	T6
52	167/75	104/40	T5	T5	T6
52	167/75	131/55	T4	T4	T4
57 [Ⓢ]	167/75	104/40	T6	T6	T6
64	167/75	104/40	T5	T5	T6
64	167/75	131/55	T4	T4	T4
84	167/75	104/40	T5	T5	T6
114 [Ⓢ]	167/75	104/40	T6	T6	T6

“T” Numbers Represent the Maximum Surface Temperature for Luminaries with AEx nA nR Rating

“T” Number	T1	T2	T3	T4	T5	T6
Temperature Range (°F)	574-842	394-572	277-392	214-275	187-212	185
Temperature Range (°C)	301-450	201-300	136-200	101-135	86-100	85

① Use 167 °F/75 °C rated supply wire.

② Fixtures with Polymeric Refractor are listed for Groups F and G only.

[Ⓢ] CSA Certification only.

Mercmaster™ III Low Profile Compact Fluorescent Luminaires



Enclosed and Gasketed. For Hazardous and Wet Locations

High Power Factor Electronic Ballast (Min. P.F. 99%), PL-T Lamps.

Class I, Division 2, Groups A, B, C, D
Class I, Zone 2, AEx nA nR IIC (Z2)
Class I, Zone 2, Ex nR IIC (Z) ¹

Class II, Division 1 and 2, Groups E, F, G
Class III
Simultaneous Exposure (Class I, Division 2/
Class II, Division 1)

Fixtures Outside Type (Salt Water)
Type 4X
IP66

	Lamp Watts	Hub Size (Inches)	Catalog Numbers ②③		
			With Globe ①④	With Type V 8" Glass Refractor ①④⑤	With Type V Polymeric Refractor ⑥
25° Stanchion					
	1 x 26 W	3/4	MLSF264G2N	MLSF264J5N	MLSF264P5N
		1	MLSF265G2N	MLSF265J5N	MLSF265P5N
	1 x 32 W	3/4	MLSF324G2N	MLSF324J5N	MLSF324P5N
		1	MLSF325G2N	MLSF325J5N	MLSF325P5N
	1 x 42 W	3/4	MLSF424G2N	MLSF424J5N	MLSF424P5N
		1	MLSF425G2N	MLSF425J5N	MLSF425P5N
	2 x 26 W	3/4	MLSF524G2N	MLSF524J5N	MLSF524P5N
		1	MLSF525G2N	MLSF525J5N	MLSF525P5N
	1 x 57 W	3/4	MLSF574G4N ¹	MLSF574J4N ¹	MLSF574P4N ¹
		1	MLSF575G4N ¹	MLSF575J4N ¹	MLSF575P4N ¹
	2 x 32 W	3/4	MLSF644G2N	MLSF644J5N	MLSF644P5N
		1	MLSF645G2N	MLSF645J5N	MLSF645P5N
Shown with Glass Globe	2 x 42 W	3/4	MLSF844G2N	MLSF844J5N	MLSF844P5N
		1	MLSF845G2N	MLSF845J5N	MLSF845P5N
	2 x 57 W	3/4	MLSF1144G4N ¹	MLSF1144J4N ¹	MLSF1144P4N ¹
		1	MLSF1145G4N ¹	MLSF1145J4N ¹	MLSF1145P4N ¹
90° Stanchion					
	1 x 26 W	3/4	MLRF264G2N	MLRF264J5N	MLRF264P5N
		1	MLRF265G2N	MLRF265J5N	MLRF265P5N
	1 x 32 W	3/4	MLRF324G2N	MLRF324J5N	MLRF324P5N
		1	MLRF325G2N	MLRF325J5N	MLRF325P5N
	1 x 42 W	3/4	MLRF424G2N	MLRF424J5N	MLRF424P5N
		1	MLRF425G2N	MLRF425J5N	MLRF425P5N
	2 x 26 W	3/4	MLRF524G2N	MLRF524J5N	MLRF524P5N
		1	MLRF525G2N	MLRF525J5N	MLRF525P5N
	1 x 57 W	3/4	MLRF574G4N ¹	MLRF574J4N ¹	MLRF574P4N ¹
		1	MLRF575G4N ¹	MLRF575J4N ¹	MLRF575P4N ¹
	2 x 32 W	3/4	MLRF644G2N	MLRF644J5N	MLRF644P5N
		1	MLRF645G2N	MLRF645J5N	MLRF645P5N
Shown with Polymeric Refractor	2 x 42 W	3/4	MLRF844G2N	MLRF844J5N	MLRF844P5N
		1	MLRF845G2N	MLRF845J5N	MLRF845P5N
	2 x 57 W	3/4	MLRF1144G4N ¹	MLRF1144J4N ¹	MLRF1144P4N ¹
		1	MLRF1145G4N ¹	MLRF1145J4N ¹	MLRF1145P4N ¹

① For fixtures with guard, substitute **G** for **N** before adding voltage suffix.

② Add voltage suffix **-BU** for 120 through 277 V, 50/60 Hz and 125 Vdc. Add voltage suffix **-A5** for 347 V, 60 Hz.

③ Add **L** after voltage suffix to include lamp.

④ Add **Z2** suffix for factory-sealed non-sparking/restricted breathing protection (Aex nA nR).

⑤ To order fixture with NEMA Type I or III glass refractor, change **J5** to **J1** or **J3** respectively.

⑥ To order fixture with NEMA Type II, III, or IV polymeric refractor, change **P5** to **P2**, **P3** or **P4** respectively. Polymeric refractor fixtures are UL Listed and CSA Certified for Class II, Division 1 and 2, Groups F and G; Class III; Marine Outdoor Salt Water (UL1598A); NEMA 4X and CSA Type 4X.

¹ CSA Certification only.

1061A



Visit our website at www.appletonelec.com or contact us at (800) 621-1506.

© January 2011

Lighting

LIGHTING: ENCLOSED AND GASKETED — AREA — FLUORESCENT

Mercmaster™ III Low Profile Compact Fluorescent Luminaire Electrical Specifications

Enclosed and Gasketed. For Hazardous and Wet Locations

Compact Fluorescent listed for simultaneous exposure to combustible dusts and flammable gases or vapors.

Class I, Division 2, Groups A, B, C, D
Class I, Zone 2, AEx nR IIC (Z2)
Class I, Zone 2, Ex nR IIC (Z) [Ⓜ]

Class II, Division 1 and 2, Groups E, F, G
Class III
Simultaneous Exposure (Class I, Division 2/
Class II, Division 1)

Fixtures Outside Type (Salt Water)
Type 4X
IP66

Line Voltage	Type of Ballast	Starting and Operating Amps	Total Watts
26 Watt PL-T Fluorescent			
120	Electronic	.250	28
277	Electronic	.110	28
347	Electronic	.080	27
32 Watt PL-T Fluorescent			
120	Electronic	.300	36
277	Electronic	.130	36
347	Electronic	.150	36
42 Watt PL-T Fluorescent			
120	Electronic	.410	48
277	Electronic	.180	48
347	Electronic	.140	43
52 Watt PL-T Fluorescent			
120	Electronic	.460	56
277	Electronic	.220	56
347	Electronic	.170	54
57 Watt PL-T Fluorescent [Ⓜ]			
120	Electronic	.480	58
277	Electronic	.210	57
347	Electronic	.180	61
64 Watt PL-T Fluorescent			
120	Electronic	.580	69
277	Electronic	.260	69
347	Electronic	.190	66
84 Watt PL-T Fluorescent			
120	Electronic	.760	91
277	Electronic	.320	91
347	Electronic	.280	86
114 Watt PL-T Fluorescent [Ⓜ]			
120	Electronic	.960	116
277	Electronic	.420	114
347	Electronic	.360	122

Fuse catalog number: MLF2 (1 required for 120 V or 277 V) – 2-Amp fuse, time delay.
Minimum starting temperature: 0 °F/-18 °C

Energy Efficiency and Lamp Life Comparison

Lamp Type	Watts	Lumens	Rated Average Life (Hours)
Incandescent	100	1750	750
Incandescent	150	2880	750
Incandescent	200 (PS-25, PS-30)	3710	750
Incandescent	200 (A-23)	4010	750
PL-T Fluorescent	26	1800	10,000
PL-T Fluorescent	32	2400	10,000
PL-T Fluorescent	42	3200	10,000
PL-T Fluorescent	52	3600	10,000
PL-T Fluorescent	57 [Ⓜ]	4300	12,000
PL-T Fluorescent	64	4800	10,000
PL-T Fluorescent	84	6400	10,000
PL-T Fluorescent	114 [Ⓜ]	8600	12,000

[Ⓜ] CSA Certification only.

Lumen Output Comparison

Light Output as Function of Temperature

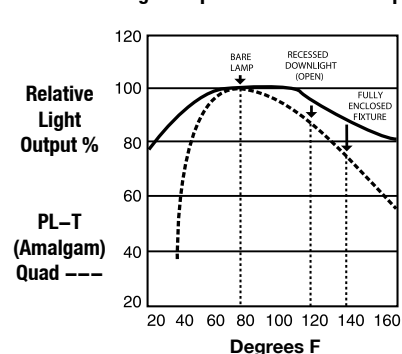

High lumen output of the amalgam technology lamp vs. the reduced light output at variable temperatures from a typical compact fluorescent lamp.

Mercmaster™ III Low Profile Compact Fluorescent Luminaire Dimensions

Enclosed and Gasketed. For Hazardous and Wet Locations

Compact Fluorescent listed for simultaneous exposure to combustible dusts and flammable gases or vapors.

Dimensions

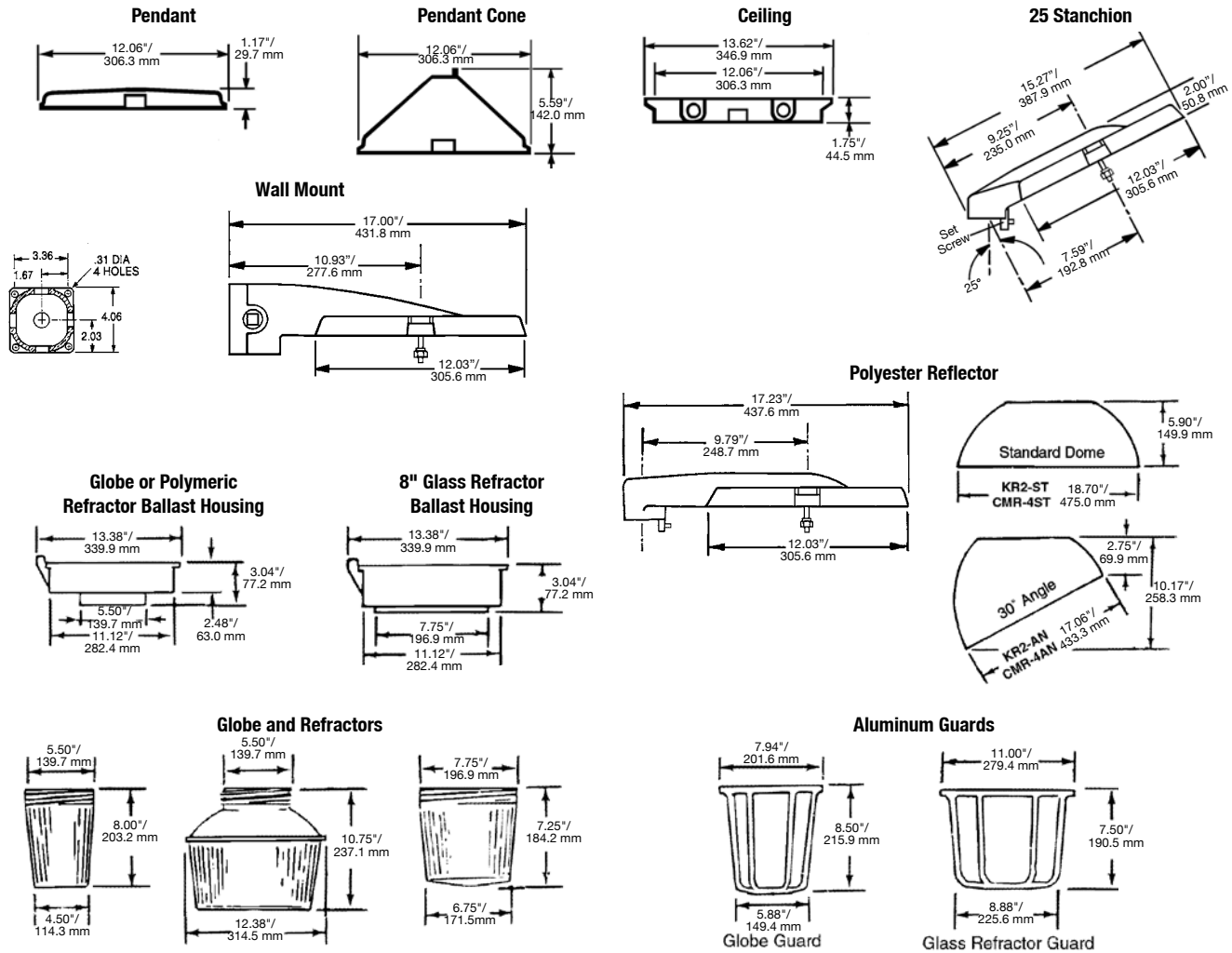

Accessory Weights ①

Ballast Housings and Mounting Hoods	Wt. Lbs/Kgs	Refractors, Globe, Guards and Reflectors	Wt. Lbs/Kgs
Pendant	2.25/1.0	8" Glass Refractor	5.25/2.4
Pendant Cone	2.50/1.1	Glass Globe	3.75/1.7
Ceiling	3.00/1.4	Glass Globe — 57/114 W [Ⓜ]	8.35/ 3.8
Wall Mount	4.00/1.8	Polymeric Refractor ②	2.43/1.1
25° Stanchion	3.25/1.5	Glass Refractor Guard	1.00/0.5
90° Stanchion	3.75/1.7	Globe Guard	1.00/0.5
Globe/Polymeric Refractor Housing	5.60/2.5	Globe Guard — 57/114 W [Ⓜ]	2.00/0.9
Glass Refractor Housing	6.50/2.9	Standard Dome	2.50/1.1
		30° Angle	2.50/1.1
		Exit Sign ②	5.00/2.3

① Weights are approximate.

② Not listed for Class I, Zone 2 areas.

[Ⓜ] CSA Certification only.

Lighting
ENCLOSED AND GASKETED — AREA — FLUORESCENT