

Pipe Hangers

TOLCO™ Fig. 200H - Heavy Duty Band Hanger (For Trapeze)

Size Range: 2" (50mm) thru 4" (100mm) trapeze pipe size.

Material: Steel — Pre-Galvanized to G40 Spec

Function: Designed primarily to support substantially heavier loads than is normally intended for the nominal hanger size. Used extensively to support trapeze installations and the increased loads from both above and below the trapeze assembly.

Features: Furnished with 3/8"-16 or 1/2"-13 adjusting threaded ring nut.

Approvals: Underwriters Laboratories listed in the USA (UL) and Canada** (cUL). Conforms to Federal Specification WW-H-171E & A-A-1192A, Type 10 and Manufacturers Standardization Society ANSI/MSS SP-69 & SP-58, Type 10.

Maximum Temperature: 650°F (343°C)

Finish: Pre-Galvanized

Order By: Part number, pipe size and rod size.

Important Design Note. Because of the increased loads applied to the trapeze assembly, both the upper trapeze supports as well as the lower hanging unit must be able to hold the maximum loads intended.

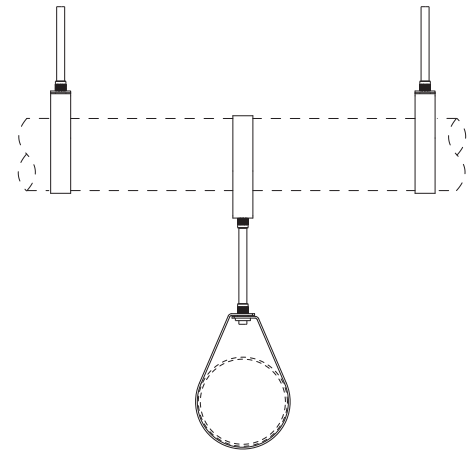
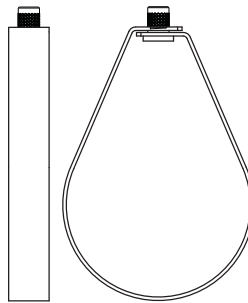
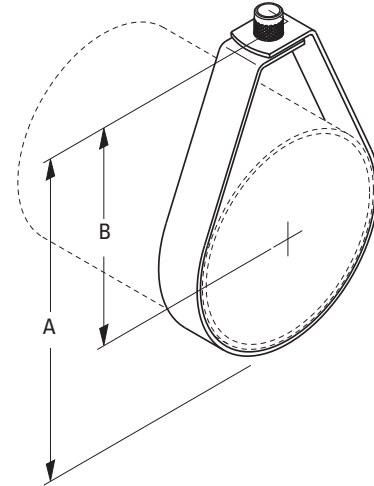

Part No.	Pipe Size		Rod Size	A		B		Max. Rec. Load		Approx. Wt./100	
	in.	(mm)		in.	(mm)	in.	(mm)	lbs.	(kN)	lbs.	(kg)
200H-2-3/8	2"	(50)	3/8"-16	4 ⁹ / ₁₆ "	(115.9)	3 ⁷ / ₃₂ "	(81.7)	1200	(5.34)	48	(21.8)
200H-2-1/2	2"	(50)	1/2"-13	4 ²³ / ₃₂ "	(119.8)	3 ³ / ₈ "	(85.7)	1200	(5.34)	45	(20.4)
200H-2 ¹ / ₂ -3/8	2 ¹ / ₂ "	(65)	3/8"-16	5 ⁵ / ₁₆ "	(134.9)	3 ²³ / ₃₂ "	(94.4)	1200	(5.34)	59	(26.7)
200H-2 ¹ / ₂ -1/2	2 ¹ / ₂ "	(65)	1/2"-13	5 ¹⁵ / ₃₂ "	(138.9)	3 ⁷ / ₈ "	(98.3)	1200	(5.34)	56	(25.4)
200H-3-3/8	3"	(75)	3/8"-16	5 ³ / ₄ "	(146.0)	3 ²⁷ / ₃₂ "	(97.6)	1200	(5.34)	63	(28.6)
200H-3-1/2	3"	(75)	1/2"-13	5 ⁷ / ₈ "	(148.1)	3 ³¹ / ₃₂ "	(100.8)	1200	(5.34)	60	(27.2)
200H-4-3/8	4"	(100)	3/8"-16	6 ⁷ / ₈ "	(174.6)	4 ⁷ / ₁₆ "	(112.7)	1200	(5.34)	76	(34.5)
200H-4-1/2	4"	(100)	1/2"-13	7 ¹ / ₃₂ "	(178.6)	4 ¹⁹ / ₃₂ "	(116.7)	1200	(5.34)	73	(33.1)

Note:

Select trapeze pipe size based on section modulus required for span of trapeze per information provided in NFPA 13 (2002) Table 9.1.1.6.1 (a and b).

All sizes are UL Listed to support up to 8" pipe at max spacing per NFPA 13.

For 6" (150mm) and 8" (200mm) trapeze pipe, consult factory.

All dimensions in charts and on drawings are in inches. Dimensions shown in parentheses are in millimeters unless otherwise specified.