

Haz

HazSpot 746D2/br



Lamp Suspension System

FEATURES

- Unique lamp suspension system design absorbs vibration to extend lamp life up to 50% longer than competitive brands.
- High temperature silicone gasket provides a watertight seal.
- Adjustable mounting allows 360° horizontal rotation, vertical positioning down 45° and up 90°. 60° up with handle option.
- Medium flood with optional narrow or wide beam pattern. Lamp included.
- Field replaceable lens and gasket.
- Protective guard available.

APPLICATIONS

- Hazardous locations
- Marine and watertight requirements
- High vibration areas
- Oil and gas exploration and production

APPROVALS

- Class I Division 2 Groups A,B,C & D
- Class I Zone 2 Groups IIA, IIB, IIB + H2 and IIC
- Type 4X
- Conforms to IP66
- Marine Outside Type Saltwater
- ABS

STANDARDS

- UL 844 - Hazardous Locations
- UL 1598A - Luminaires for Marine Vessels

TECHNICAL SPECIFICATIONS

HOUSING

Cast marine brass.

MOUNTING BASE

Cast marine brass.

GUARD

Stainless steel, optional.

LENS

Clear heat resistant glass.

ENTRIES

One 1/2" NPT outlet, optional 3/4" NPT.

HARDWARE

Stainless steel.

GASKET

One piece silicone.

LAMP TYPE

300w Medium Floodlight PAR56 or 500w Quartz Halogen. Lamp included. Optional narrow spot or wide beam lamps.

LAMP HOLDER

Mogul end prong, porcelain. Low voltage lamps wired direct.

VOLTAGE OPERATION

Rated for operation on 120v. Optional 12v and 28v versions.

MOUNTING

Surface type.

TERMINAL BLOCK

2 pole terminal block.

ORDERING REFERENCES

PART NUMBER	DESCRIPTION	WEIGHT LBS	ANSI LAMP TYPE	T-CODE	AMBIENT	SUPPLY WIRE
746B	300W Incandescent	56.0	PAR-56/MFL	T1	40°C	110°C
746BQ	500W Quartz Halogen	56.0	PAR-56Q/ML	T1	40°C	110°C

SPECIAL OPTIONS

- GRD - Guard
- NSP* - Narrow Spot Light Type
- WFL* - Wide Floodlight Type
- HDL - Handle and Clamp
- 12 - 12v Medium Floodlight Type (300w)
- 28** - 28v Medium Floodlight Type (450w)

*For 120v only.

**10 hour lamp life.

SPARE PARTS

Part No.	Description	Part No.	Description
INX1014	LAMP HOLDER	INX3509	LAMP, 300w MFL 120v
INX1041	GUARD	INX3510	LAMP, 300w NSP 120v
GKT6095	FRAME GASKET	INX3581	LAMP, 300w WFL 120v
INX2143	LENS	INX3511	LAMP, 500w MFL 120v
INX9037B	LENS AND FRAME ASSEMBLY	INX3582	LAMP, 500w NSP 120v
INX7048B	STANDARD MOUNT	INX3583	LAMP, 500w WFL 120v
FX3001	TERMINAL BLOCK	INX3576	LAMP, 300w MFL 12v
INX8099	SWING BOLT/NUT KIT Stainless steel (4 per pkg)	INX3575	LAMP, 450w MFL 28v (10 hour lamp life)

DIMENSIONS

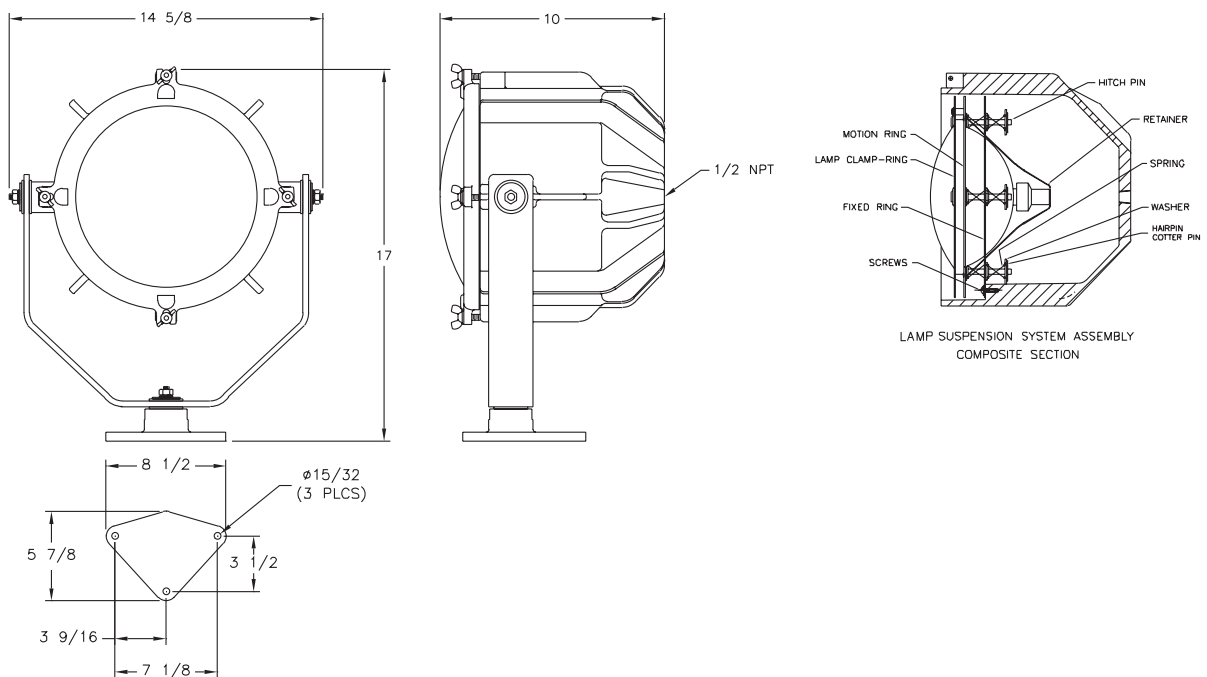

Dimensions in inches