



SAFETY POSITION SWITCHES WITH SOLENOID INTERLOCKING LOCK. FORCE 2600N,5 APPR. DIR. METAL HOUSING,3X(M20X1.5) SPRING-LOCKED, ESCAPE RELEASE FROM REAR AND AUX. RELEASE WITH LOCK ON FRONT, MAGNET VOLTAGE 24V DC, MONITOR. OF ACTUATOR 2NC/1NO, MONITOR. OF MAGNET 2NC/1NO

<b>Product designation</b>	position switch with tumbler
<b>Design of the product</b>	with separate actuator and with tumbler
<b>Manufacturer's article number</b>	
<ul style="list-style-type: none"> <li>of the optional actuators</li> </ul>	3SE5000-0AV01 standard actuator, 3SE5000-0AV02 actuator with vertical mounting, 3SE5000-0AV03 actuator with transverse mounting, 3SE5000-0AV04 radius actuator left, 3SE5000-0AV05 universal actuator, 3SE5000-0AV06 radius actuator right, 3SE5000-0AV07 heavy duty actuator

General technical data:	
<b>Product function</b>	
<ul style="list-style-type: none"> <li>positive opening</li> </ul>	Yes
<b>Insulation voltage</b>	
<ul style="list-style-type: none"> <li>rated value</li> </ul>	250 V
<b>Surge voltage resistance rated value</b>	4 kV
<b>Protection class IP</b>	IP65/IP67
<b>Degree of pollution</b>	class 3
<b>Shock resistance</b>	30g / 11 ms
<ul style="list-style-type: none"> <li>acc. to IEC 60068-2-27</li> </ul>	30 g / 11 ms
<b>Vibration resistance</b>	0.35 mm / 5g

<ul style="list-style-type: none"> <li>• acc. to IEC 60068-2-6</li> </ul>	0.35 mm/5g
<b>Mechanical service life (switching cycles)</b>	
<ul style="list-style-type: none"> <li>• typical</li> </ul>	1 000 000
<b>Electrical endurance (switching cycles) with contactor 3RH11, 3RT1016, 3RT1017, 3RT1024, 3RT1025, 3RT1026 typical</b>	1 000 000
<b>Electrical operating cycles in one hour with contactor 3RH11, 3RT1016, 3RT1017, 3RT1024, 3RT1025, 3RT1026</b>	6 000
<b>Thermal current</b>	6 A
<b>Material of the enclosure of the switch head</b>	metal
<b>Equipment marking</b>	
<ul style="list-style-type: none"> <li>• acc. to DIN EN 61346-2</li> </ul>	B
<ul style="list-style-type: none"> <li>• acc. to DIN EN 81346-2</li> </ul>	B
<b>Continuous current of the C characteristic MCB</b>	1 A; for a short-circuit current smaller than 400 A
<b>Continuous current of the quick DIAZED fuse link</b>	10 A; for a short-circuit current smaller than 400 A
<b>Continuous current of the DIAZED fuse link gG</b>	6 A; for a short-circuit current smaller than 400 A
<b>Locking force</b>	2 600 N
<ul style="list-style-type: none"> <li>• acc. to DIN EN ISO 14119</li> </ul>	2 000 N
<b>Repeat accuracy</b>	0.05 mm
<b>Minimum actuating force in activation direction</b>	30 N
<b>Operating current at AC-15</b>	
<ul style="list-style-type: none"> <li>• at 24 V rated value</li> </ul>	6 A
<ul style="list-style-type: none"> <li>• at 125 V rated value</li> </ul>	3 A
<ul style="list-style-type: none"> <li>• at 230 V rated value</li> </ul>	1.5 A
<b>Operating current at DC-13</b>	
<ul style="list-style-type: none"> <li>• at 24 V rated value</li> </ul>	3 A
<ul style="list-style-type: none"> <li>• at 125 V rated value</li> </ul>	0.55 A
<ul style="list-style-type: none"> <li>• at 230 V rated value</li> </ul>	0.27 A

#### Enclosure:

<b>Design of the housing</b>	special design
<b>Material of the enclosure</b>	metal
<b>Coating of the enclosure</b>	cathodic immersion coating
<b>Design of the housing acc. to standard</b>	No

#### Drive Head:

<b>Design of the operating mechanism</b>	5 directions of approach
<b>Design of the switching function</b>	positive opening
<b>Number of actuation directions</b>	5

#### Connections/ Terminals:

<b>Type of electrical connection</b>	screw-type terminals
--------------------------------------	----------------------

#### Mechanical data:

<b>Cable entry type</b>	3 x (M20 x 1.5)
-------------------------	-----------------

Locking mechanism design	spring-locked (closed-circuit current principle) with escape unlocking at the rear and lock on the front
--------------------------	--

Communication/ Protocol:

Design of the interface	without
-------------------------	---------

Ambient conditions:

Ambient temperature	
<ul style="list-style-type: none"> <li>during operation</li> <li>during storage</li> </ul>	<p>-25 ... +60 °C</p> <p>-40 ... +80 °C</p>





Supply voltage:

Supply voltage of magnet coil	24 V
-------------------------------	------

Installation/ mounting/ dimensions:

Mounting position	any
Mounting type	screw fixing

Certificates/approvals

General Product Approval	Functional Safety/Safety of Machinery	Declaration of Conformity	other
 CCC	 CSA		 EG-Konf.
		<a href="#">Baumusterprüfbescheinigung</a>	<a href="#">Bestätigungen</a>

Further information

- Information- and Downloadcenter (Catalogs, Brochures,...)**  
<http://www.siemens.com/industrial-controls/catalogs>
- Industry Mall (Online ordering system)**  
<https://mall.industry.siemens.com/mall/en/en/Catalog/product?mlfb=3SE53120SH11>
- Cax online generator**  
<http://support.automation.siemens.com/WW/CAXorder/default.aspx?lang=en&mlfb=3SE53120SH11>
- Service&Support (Manuals, Certificates, Characteristics, FAQs,...)**  
<https://support.industry.siemens.com/cs/ww/en/ps/3SE53120SH11>
- Image database (product images, 2D dimension drawings, 3D models, device circuit diagrams, EPLAN macros, ...)**  
[http://www.automation.siemens.com/bilddb/cax\\_de.aspx?mlfb=3SE53120SH11&lang=en](http://www.automation.siemens.com/bilddb/cax_de.aspx?mlfb=3SE53120SH11&lang=en)

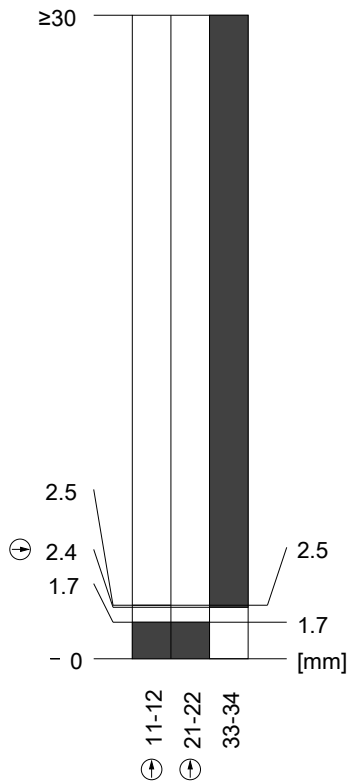
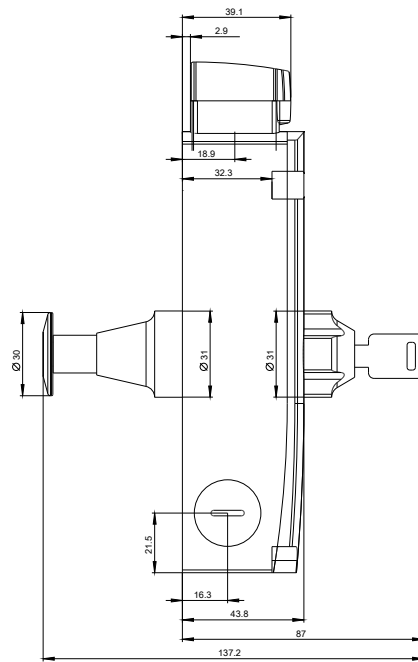
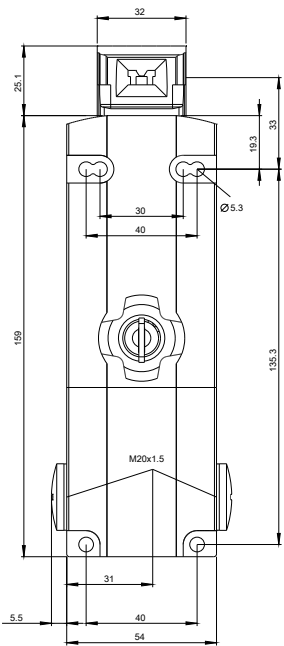

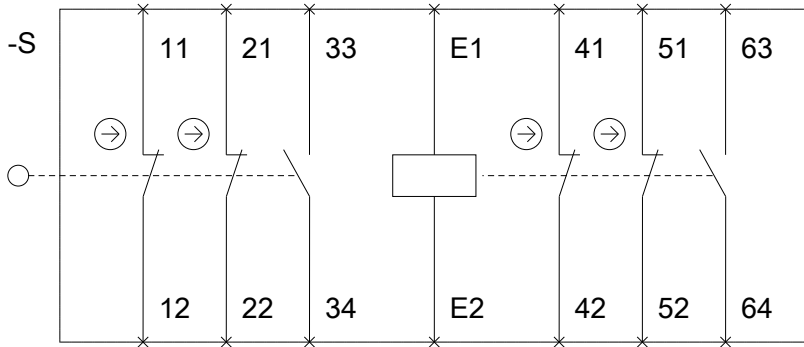

last modified:

19.03.2016