

CONDUCTOR SIZE (AWG)	RECOMMENDED TORQUE (IN-LB) 3
8	75
6	110
4	110
2	150
1	150
1/0	180

REV	DATE	DESCRIPTION	ECO	BY	C'H'K.
B	02/21/2014	DRAWING RELEASED	34856	GP	MA

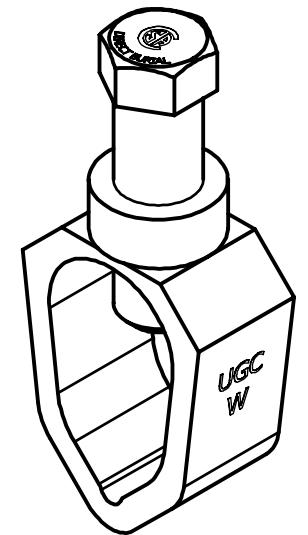
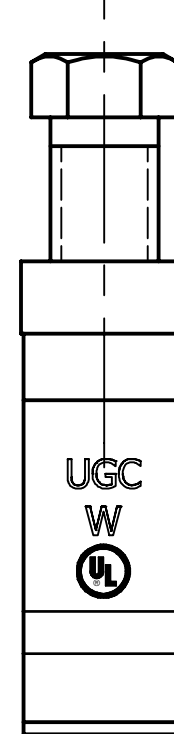
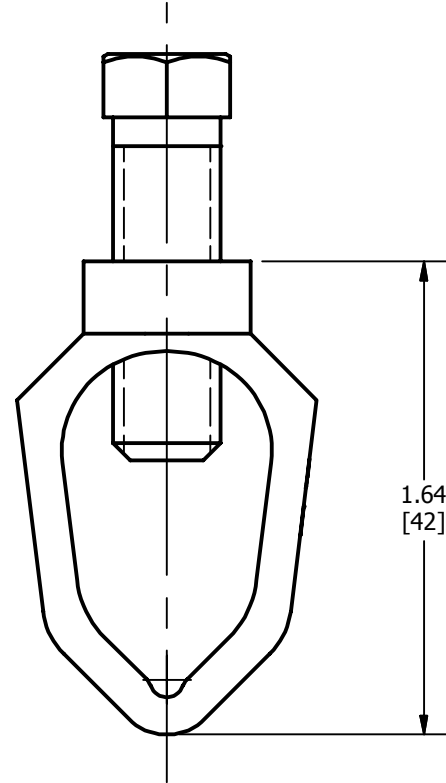
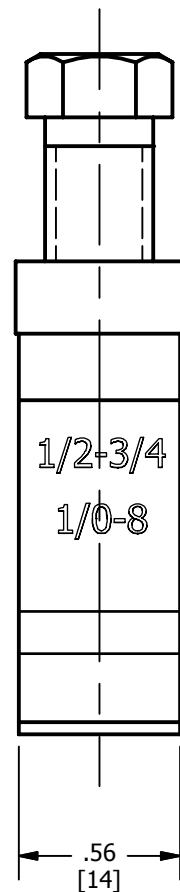
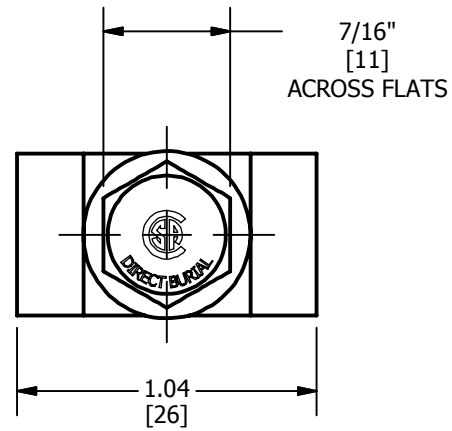

NOTES:

- MATERIAL: BODY : CAST COPPER ALLOY
BOLT : SILICON BRONZE
- ACCOMMODATES GROUND ROD : SIZES 1/2", 5/8" AND 3/4"
CONDUCTOR : SIZES #8 AWG THROUGH 1/0 AWG
- 3 RECOMMENDED TORQUE VALUES ARE THE SAME, REGARDLESS OF WHICH GROUND ROD SIZE IS USED.
- UL LISTED TO UL467 FOR GROUNDING AND BONDING.
CSA CERTIFIED TO CSA 22.2 NO. 41 FOR GROUNDING AND BONDING.
- DIMENSIONS IN BRACKETS [] ARE IN MILLIMETERS, ROUNDED OFF TO THE NEAREST MILLIMETER AND ARE FOR REFERENCE ONLY.

TO ORDER BURNDY® PRODUCTS CALL UNITED STATES 1-800-346-4175 (LONDONDERRY, NH) CANADA: 1-800-361-6975 (QUEBEC) 1-800-387-6487 (ALL OTHER PROVINCES) FOR PRODUCT INFO: http://www.burndy.com		GROUND CLAMP, RANGE TAKING	
		ITEM NO: 10074191	
CAT. NO: GCRT1/0			
DRAWN BY: P. SRIDHAR 11/30/2010			
CHECKER: P. WASON 11/30/2010			
DSN APRVL: P. WASON 11/30/2010			
MFG APRVL: --			
QA APRVL: J. BRODEUR 12/01/2010		PROJ. NO: --	
MKT APRVL: P. THERRIEN 11/30/2010		DRAWING NO: 30008698	
PROD FAM: --		REV: B	
PROJECT #: --		SIZE: B	
DOCUMENT TYPE: SALES		SHEET 1 OF 2	
REL LEVEL: Released			

REV	DATE	DESCRIPTION	ECO	BY	C'H'K.
B	02/21/2014	DRAWING RELEASED	34856	GP	MA

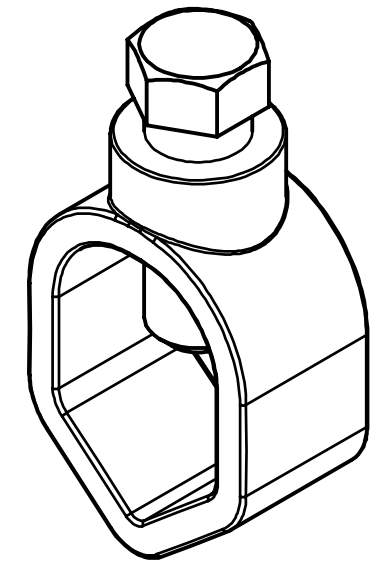
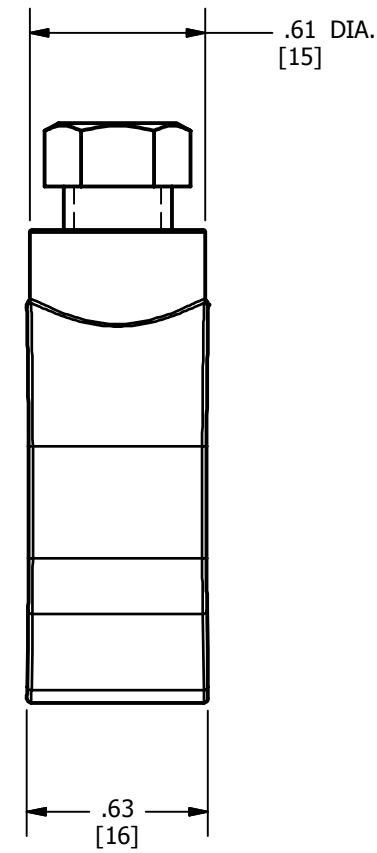
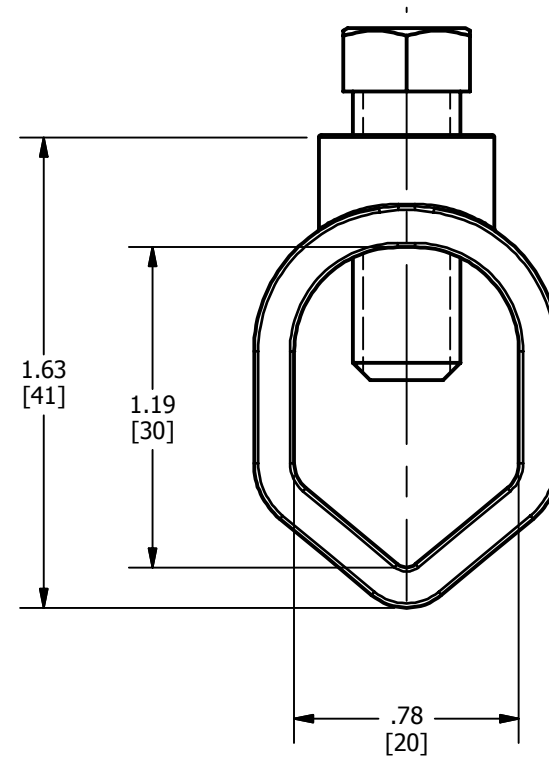
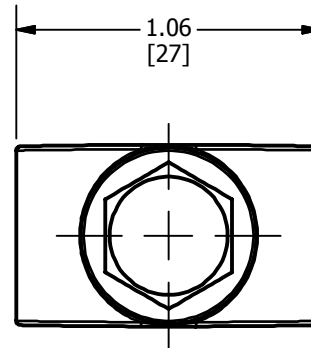

NOTE:

1. WIRE SIZE RANGE: 10 SOL. - 1/0 STR.
ROD SIZE RANGE: 1/2" - 3/4"

TO ORDER BURNDY® PRODUCTS CALL		GROUND CLAMP, RANGE TAKING	
UNITED STATES		ITEM NO: 10074191	
1-800-346-4175 (LONDONDERRY, NH)		CAT. NO: GCRT1/0	
CANADA:		DRAWN BY: P. SRIDHAR 11/30/2010	
1-800-361-6975 (QUEBEC)		CHECKER: P. WASON 11/30/2010	
1-800-387-6487 (ALL OTHER PROVINCES)		DSN APRVL: P. WASON 11/30/2010	
FOR PRODUCT INFO: http://www.burndy.com		MFG APRVL: --	
		QA APRVL: J. BRODEUR 12/01/2010	
		MKT APRVL: P. THERRIEN 11/30/2010	
		PROD FAM: --	
		DRAWING NO	
		30008698	
		REV	
		B	
		SHEET 2 OF 2	