

FIGURE 1

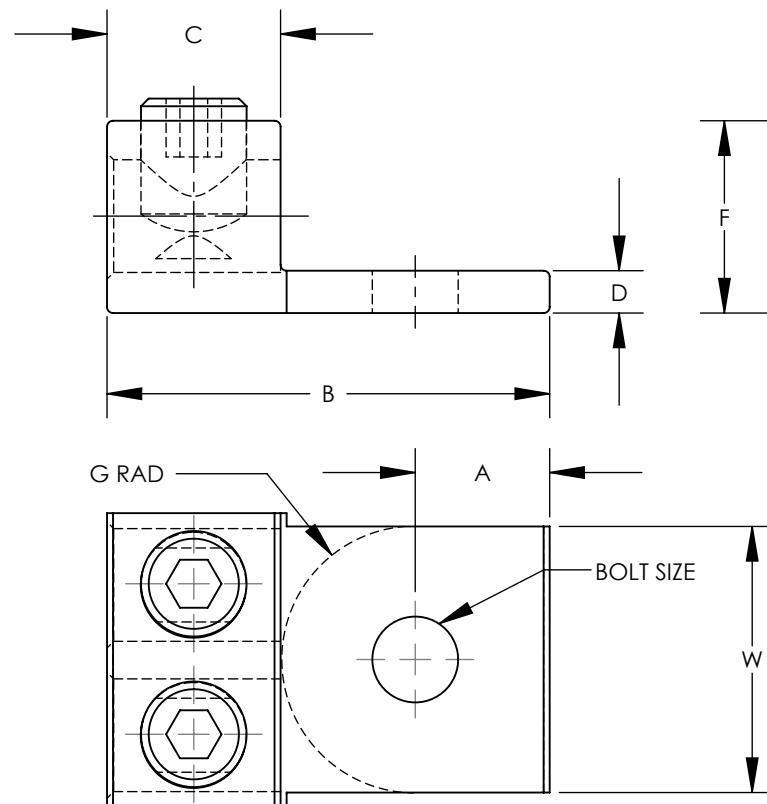
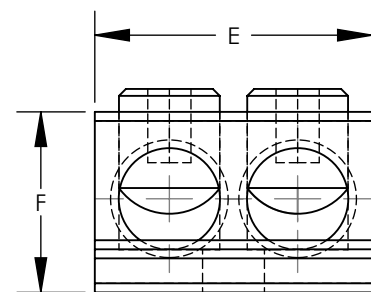
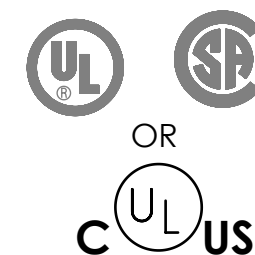

FIGURE 2

NOTES:

1. MATERIAL:
BODY - ALUMINUM, TIN PLATED
SCREW - ALUMINUM, TIN PLATED
2. UL LISTED, CSA CERTIFIED, OR cULus FOR USE UP TO 600V & TEMPERATURE RATED 90°C (AL9CU)
3. DUAL RATED FOR USE WITH COPPER OR ALUMINUM STRANDED CODE CONDUCTOR
4. THESE PARTS ARE RoHS COMPLIANT
5. USE OF OXIDE INHIBITING JOINT COMPOUND LIKE PANDUIT CMP-100 RECOMMENDED FOR PAD TO PAD AND CONDUCTOR SURFACES
6. SEE PACKAGING LABEL FOR TIGHTENING TORQUE INFORMATION
7. PKG QTY:
6 = 6



PART NUMBER	FIGURE	WIRE RANGE COPPER/ALUMINUM	WIRE STRIP LENGTH - IN [mm]	STUD SIZE IN	DIMENSIONS - IN [mm]								HEX KEY*	AGENCY
					A ± .02 [.5]	B ± .05 [1.3]	C ± .03 [.8]	D ± .03 [.8]	E ± .04 [1]	F ± .03 [.8]	G ± .02 [.5]	W ± .05 [1.3]		
LAM2A1/0-14-6Y	1	14 AWG - 1/0 AWG	.62 [15.7]	1/4	0.43 [10.8]	1.47 [37.3]	0.62 [15.7]	0.19 [4.8]	1.13 [28.6]	0.78 [19.9]	0.42 [10.7]	N/A	SLOTTED	cULus
LAM2A2/0-14-6Y	1	14 AWG - 2/0 AWG	.62 [15.7]	1/4	0.43 [10.8]	1.47 [37.3]	0.62 [15.7]	0.19 [4.8]	1.20 [30.6]	0.78 [19.9]	0.42 [10.7]	N/A	3/16	cULus
LAM2A250-38-6Y	2	6 AWG - 250 kcmil	1.00 [25.4]	3/8	0.51 [13.0]	2.56 [65.1]	1.00 [25.4]	0.25 [6.4]	1.64 [41.7]	1.19 [30.2]	1.05 [26.7]	1.50 [38.0]	5/16	cULus
LAM2A350-12-6Y	2	6 AWG - 350 kcmil	1.13 [28.6]	1/2	0.88 [22.2]	2.88 [73.2]	1.13 [28.7]	0.28 [7]	1.91 [48.4]	1.25 [31.8]	0.86 [21.8]	1.73 [44.0]	5/16	cULus
LAM2A600-12-6Y	2	2 AWG - 600 kcmil	1.38 [34.9]	1/2	0.63 [16.0]	3.19 [81.0]	1.38 [34.9]	0.44 [11.2]	2.38 [60.5]	1.56 [39.6]	1.19 [30.2]	2.00 [50.8]	3/8	UL & CSA
LAM2A61000-58-6Y	1	500 kcmil - 1000 kcmil	1.63 [41.4]	5/8	0.88 [22.2]	3.50 [88.9]	1.63 [41.4]	0.50 [12.7]	3.50 [88.9]	1.94 [49.3]	1.00 [25.4]	N/A	3/8	UL & CSA

* HEX SIZE MAY DIFFER FROM CHART. DIFFERENCE IN SIZE WILL NOT AFFECT FIT, FORM, OR FUNCTION OF PART

REV	DATE	BY	CHK	APR	DESCRIPTION	ECN
09	6/19	JHNU	JHNU	RGB	REVISED DIMENSION B FOR LAM2A350-12-6Y: 2.88 WAS 2.87 REVISED DIMENSION C FOR LAM2A350-12-6Y: [28.7] WAS 28.6 REVISED DIMENSION D FOR LAM2A350-12-6Y: .28 WAS .25 REVISED DIMENSION E FOR LAM2A350-12-6Y: [48.4] WAS [48.6] REVISED TOLERANCES	048049
08	2/13	JHNU	JHNU	RGB	REVISED TITLE BLOCK	10N006AT-NC

TITLE		LAM2A SERIES ALUMINUM MECHANICAL LUGS CUSTOMER DRAWING		
ITEM REVISION NAME	10N006AT/09			
DATASET FILE NAME	10N006AT-NC/09.SLDDRW			
UNLESS OTHERWISE SPECIFIED, DIMENSIONAL TOLERANCES ARE: IN [mm]		MATERIAL		
.X ±	.XXX ±	SEE NOTES		
.XX ±	ANGLES ±	DRAWING NUMBER 10N006AT-NC		
THIRD ANGLE PROJECTION		DRAWN BY JHNU		
DATE 2/06	CHK JHNU	SCALE NONE	SHEET 1 OF 1	
				SIZE B