

# PD45 Series PicoDot Polarized Retroreflective and Convergent Laser Sensors



## Datasheet



- Compact and lightweight; ideal for use on robotic end effectors
- Class 2 laser diode light source
- Convergent beam models have precise, high-energy sensing spot at focus, available in four focal lengths: 50 mm (2 in), 100 mm (4 in), 200 mm (8 in), and 300 mm (12 in)
- Retroreflective models have precise, narrow beam; excellent for sensing the presence of tiny parts at close range, small parts at medium ranges, and for accurate sensing over long distances
- Fast, 0.2 millisecond sensing response for high-speed sensing or counting
- 10 to 30 V dc operation; choice of NPN or PNP complementary solid state output
- Choose models with 2 m (6.5 ft) or 9 m (30 ft) unterminated cable, or with 150 mm (6 in) Euro-style pigtail quick-disconnect (QD) connector

Retroreflective-Mode Models. Excellent for applications where high sensing power and small beam size are important. Operates over sensing ranges typically accomplished only by conventional opposed-mode photoelectrics; uses a special filter to polarize the emitted light, filtering out unwanted reflections from shiny objects. (Visible Red; Class 2 laser; 650 nm)

Retroreflective-Mode Models				
Models	Range	Cable	Output Type	Excess Gain <sup>1</sup>
PD45VN6LLP	0.2 m to 10.6 m (8 in to 35 ft) <sup>2</sup>	2 m (6.5 ft) cable	NPN	
PD45VN6LLPQ		5-pin QD 150 mm (6 inch) pigtail		
PD45VP6LLP		2 m (6.5 ft) cable	PNP	
PD45VP6LLPQ		5-pin QD 150 mm (6 inch) pigtail		

To order 9 m (30 ft) cables, add the suffix "W/30" to the model number of any cabled sensor (e.g., PD45VN6LLP W/30). Models with QD connectors require an optional mating cable.

Convergent-Mode Models. Excels at sensing small parts and profiles and uses fixed-field technology to ignore objects beyond the maximum sensing distance. (Visible Red; Class 2 laser; 650 nm)

<sup>1</sup> Performance curves based on BRT-51X51BM retro target

<sup>2</sup> Range tested using a BRT-51X51BM retro target (included with each sensor). Actual range depends on the efficiency and size of the retroreflective target used. Some targets have produced ranges up to 39.6 m (130 ft).

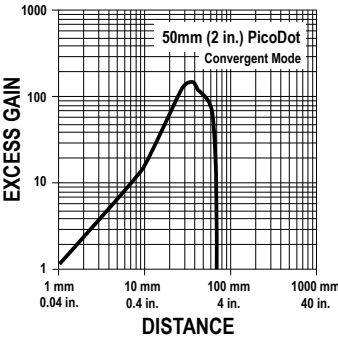
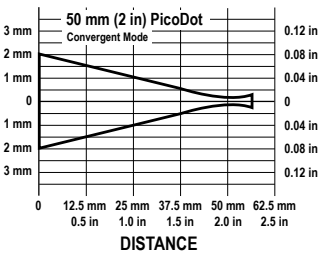

Convergent-Mode Models - 50 mm (2 inch) Focus (Performance curves based on 90% white test card)				
Models	Cable	Output Type	Excess Gain	Beam Width
PD45VN6C50	2 m (6.5 ft) cable	NPN		
PD45VN6C50Q	5-pin QD 150 mm (6 inch) pigtail			
PD45VP6C50	2 m (6.5 ft) cable	PNP		
PD45VP6C50Q	5-pin QD 150 mm (6 inch) pigtail			

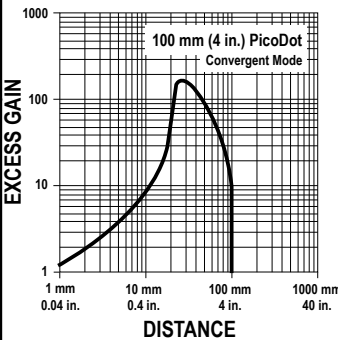
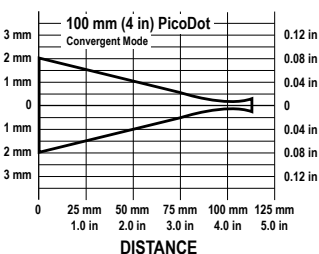
Convergent-Mode Models - 102 mm (4 inch) Focus (Performance curves based on 90% white test card)				
Models	Cable	Output Type	Excess Gain	Beam Width
PD45VN6C100	2 m (6.5 ft) cable	NPN		
PD45VN6C100Q	5-pin QD 150 mm (6 inch) pigtail			
PD45VP6C100	2 m (6.5 ft) cable	PNP		
PD45VP6C100Q	5-pin QD 150 mm (6 inch) pigtail			

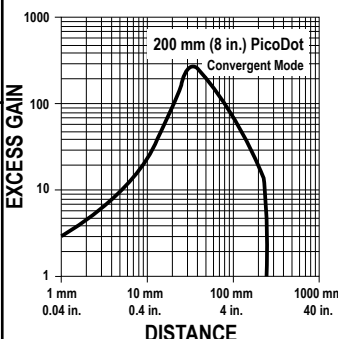
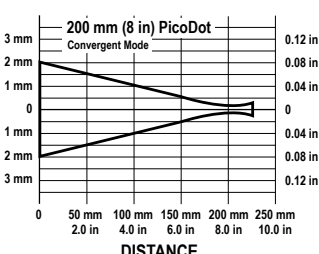
Convergent-Mode Models - 203 mm (8 inch) Focus (Performance curves based on 90% white test card)				
Models	Cable	Output Type	Excess Gain	Beam Width
PD45VN6C200	2 m (6.5 ft) cable	NPN		
PD45VN6C200Q	5-pin QD 150 mm (6 inch) pigtail			
PD45VP6C200	2 m (6.5 ft) cable	PNP		
PD45VP6C200Q	5-pin QD 150 mm (6 inch) pigtail			

## Specifications

---

### Sensing Beam

Visible red Class 2 laser, 650 nm

### Supply Voltage

10 to 30 V dc (10% max. ripple) at less than 20 mA, exclusive of load

### Beam Size at Aperture (Retroreflective Models)

3.75 mm × 1.85 mm (0.15 in × 0.07 in)

### Beam Divergence (Retroreflective Models)

Approximately 1 milliradian

### Laser Classification

Class 2 safety (CDRH (FDA) 1040.10 and IEC 60875-1)

### Supply Protection Circuitry

Protected against reverse polarity, over voltage, and transient voltages

### Delay at Power Up

< 1 second

### Output Configuration

SPDT (complementary) solid-state switch; choose NPN (current sinking) or PNP (current sourcing) models  
 Light operate: Normally-open output conducts when the sensor sees its own modulated light  
 Dark operate: Normally-closed output conducts when the sensor sees dark

### Output Rating

150 mA maximum (each output)  
 OFF-state leakage current: < 1 microamp at 30 V dc  
 ON-state saturation voltage: < 0.3 V at 10 mA dc; < 0.8 V at 150 mA dc

### Output Protection

Protected against continuous overload or short-circuit of outputs; Overload trip point ≥ 220 mA

### Output Response Time

0.2 ms (200 μs) ON and OFF

### Repeatability

50 μs

### Adjustments

12-turn slotted brass Gain (sensitivity) adjustment potentiometer (clutched at both ends of travel)

### Extinguishing Wire

Gray wire held "low" for laser operation; "high" to turn laser OFF; Low ≤ 1.0 V dc; High ≥  $V_{supply} - 4.0$  V dc (< 30 V dc) or disconnect wire; 100 ms delay upon enable

### Indicators

Two LEDs: green and amber

Green solid: power to sensor is ON

Amber solid: light is sensed; normally open output is conducting

Green flashing: output overloaded

Amber flashing: marginal excess gain

### Construction

Housings are heat-resistant ABS/polycarbonate alloy, UL94-VO rated; acrylic lens cover

### Environmental Rating

NEMA 3; IEC IP54

### Connections

2 m (6.5 ft) or 9 m (30 ft) attached cable, or 5-pin Euro-style 150 mm (6 in) pigtail quick-disconnect fitting; mating cables for QD models are ordered separately

### Operating Conditions

Temperature: -10 °C to +45 °C (14 °F to 113 °F)

Maximum relative humidity: 90% at 50 °C (non-condensing)

### Weight

Sensor only: 22 g (0.8 oz)

Sensor plus 2 m cable: 62 g (2.2 oz)

### Application Notes

False pulse may occur < 1 second after power-up

Certifications (all models except PD4\*V..C300 Series)



## Dimensions

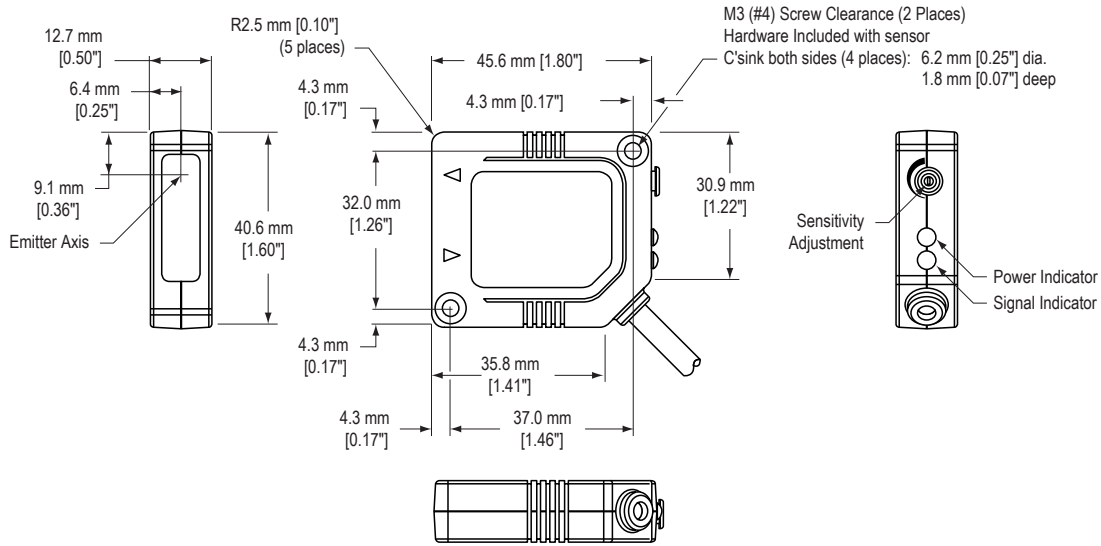

## Wiring Diagrams

Quick disconnect wiring is functionally the same.

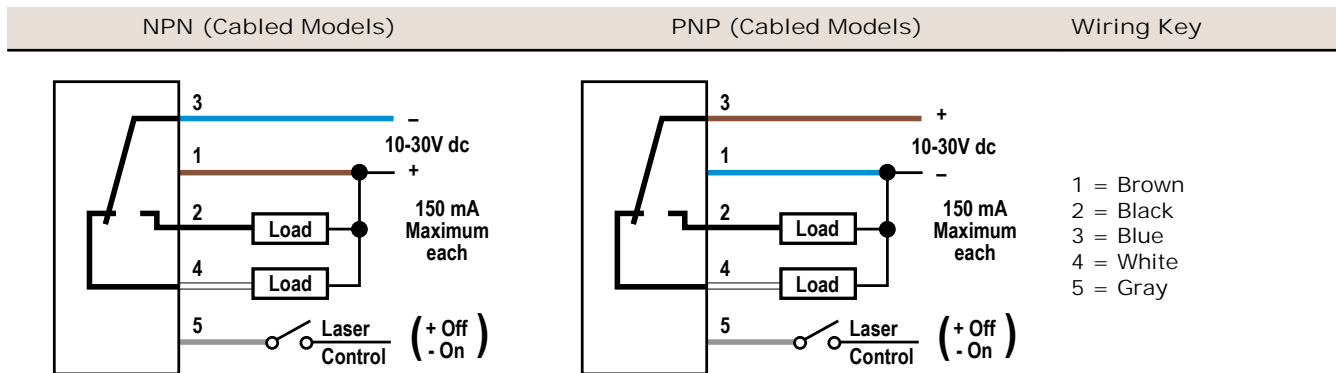

## Accessories

5-Pin Threaded M12/Euro-Style Cordsets (Single Ended)				
Model	Length	Style	Dimensions	Pinout (Female)
MQDC1-501.5	0.50 m (1.5 ft)	Straight		<p>1 = Brown 2 = White 3 = Blue 4 = Black 5 = Gray</p>
MQDC1-506	1.83 m (6 ft)			
MQDC1-515	4.57 m (15 ft)			
MQDC1-530	9.14 m (30 ft)			