

# Q45VR2 Series Sensors



## Datasheet



- Advanced one-piece photoelectric sensors with outstanding optical performance and extremely rugged design
- Operate from 90 to 250 V ac (50/60 Hz)
- SPDT electromechanical relay output for economical, high-capacity switching and immunity to electrical noise
- Multiple sensing modes include: opposed, diffuse, retroreflective, and convergent, plus glass and plastic fiber optic models
- Switchable light/dark operate
- Versatile plug-in modules available for output timing logic and/or signal strength display
- Highly visible Power, Signal (AID™ System <sup>1</sup>), and Output indicator LEDs
- Choice of prewired 2 m (6.5 ft) or 9 m (30 ft) unterminated cable or Mini-style quick-disconnect fitting
- Versatile mounting options
- Designed to withstand 1200 psi washdown; exceeds its NEMA 6P and IEC IP67 rating



**WARNING: Not To Be Used for Personnel Protection**

Never use this device as a sensing device for personnel protection. Doing so could lead to serious injury or death. This device does not include the self-checking redundant circuitry necessary to allow its use in personnel safety applications. A sensor failure or malfunction can cause either an energized or de-energized sensor output condition.

Opposed-Mode Emitter (E) and Receiver (R) Models	
Because of their extremely high excess gain, these opposed-mode sensors are an excellent option for sensing in contaminated or dirty areas, and are also the best choice for long-range sensing.	
Range: 60 m (200 ft)	<p style="text-align: center;"><b>OPPOSED</b></p> <p style="text-align: center;">Infrared, 880 nm</p>
Output Type: SPDT Electro-mechanical relay	
Effective Beam: 13 mm	

Models	Cable	Excess Gain	Beam Pattern
Q452E Emitter	2-wire 2 m (6.5 ft) cable		
Q45VR2R Receiver	5-wire 2 m (6.5 ft) cable		
Q452EQ Emitter	3-Pin Mini-style QD		
Q45VR2RQ Receiver	5-Pin Mini-style QD		

To order the 9 m (30 ft) cable model, add suffix "W/30" to the cabled model number. (For example: Q452E W/30.) Models with a QD connector require a mating cable.

<sup>1</sup> U.S. Patent no. 4356393

Retroreflective-Mode Models	
<p>The visible red sensing beam of these sensors makes them very easy to align. Model Q45VR2LP polarizes the emitted light and filters out unwanted reflections, making sensing possible in applications otherwise considered unsuited to retroreflective sensing. Specified using the model BRT-3 3-inch reflector (see the Accessories section of your current Banner catalog for further information).</p>	
<p>Output Type: SPDT Electro-mechanical relay</p>	<p>Visible red, 680 nm (non-polarized)      Visible red, 680 nm (polarized)</p>

Non-Polarized - Range 0.08 to 9 m (3 in to 30 ft)			
Models	Cable	Excess Gain	Beam Pattern
Q45VR2LV	5-wire 2 m (6.5 ft) cable		
Q45VR2LVQ	5-Pin Mini-style QD		

Polarized - Range 0.15 to 6 m (6 in to 20 ft)			
Models	Cable	Excess Gain	Beam Pattern
Q45VR2LP	5-wire 2 m (6.5 ft) cable		
Q45VR2LPQ	5-Pin Mini-style QD		

To order the 9 m (30 ft) cable model, add suffix "W/30" to the cabled model number. (For example: Q45VR2LV W/30.) Models with a QD connector require a mating cable.

## Specifications

---

### Supply Voltage and Current

- 90 to 250 V ac (50/60 Hz)
- Average current 20 mA
- Peak current 500 mA at 120 V ac, 750 mA at 250 V ac

### Supply Protection Circuitry

- Protected against transient voltages

### Output Configuration

- SPDT (Single-Pole Double-Throw) electromechanical relay output. All models except emitters.

### Output Rating

- Max. switching power (resistive load): 150 W, 600 VA
- Max. switching voltage (resistive load): 250 V ac, 30 V dc
- Max. switching current (resistive load): 5 A at 250 V ac
- Min. voltage and current: 5 V dc, 0.1 mA
- Mechanical life of relay: 10,000,000 operations
- Electrical life of relay at full resistive load: 100,000 operations

### Output Protection Circuitry

- Protected against false pulse on power-up

### Output Response Time

- 15 milliseconds ON and OFF
- (NOTE: 100 millisecond delay on power-up. Output is de-energized during this time.)

### Environmental Rating

- NEMA 6P, IEC IP67

### Operating Conditions

- Temperature: -40 °C to 70 °C (-40 °F to 158 °F)
- Maximum relative humidity: 90% at 50 °C (non-condensing)

### Certifications



### Repeatability

- Opposed mode: 0.25 milliseconds
- All other sensing modes: 0.5 milliseconds
- Response time and repeatability specifications are independent of signal strength.

### Adjustments

- Light/Dark Operate select switch and multi-turn Sensitivity control (allows precise sensitivity setting – turn clockwise to increase gain).
- Optional logic and logic/display modules have adjustable timing functions.

### Indicators

- Indicator LEDs are clearly visible beneath a raised transparent Lexan® dome on top of the sensor
- Power (green) LED lights when 90 to 250 V ac power is applied
- Signal (red) AID™ System LED lights when the sensor sees its modulated light source and pulses at a rate proportional to the strength of the received light signal
- Load (amber) LED lights whenever the output relay is energized
- Optional 7-element LED signal strength display modules

### Construction

- Molded reinforced thermoplastic polyester housing, o-ring-sealed transparent polycarbonate cover, molded acrylic lenses, and stainless steel hardware. Q45s are designed to withstand 1200 psi washdown.
- The base of cabled models has a 1/2-inch NPS integral internal conduit thread.

### Connections

- PVC-jacketed 2-wire (emitters) or 5-wire (all others) 2 m (6.5 ft) or 9 m (30 ft) unterminated cables, or 3-pin (emitters) or 5-pin (all others) Mini-style quick-disconnect (QD) fittings are available (“Q” - suffix models).
- QD cables are ordered separately.

### Application Notes

- Transient suppression is recommended for contacts switching inductive loads.
- Optional output timing modules are available.

# Dimensions

## Opposed, Retro, and Diffuse Sensing Modes (Model Suffix E, R, D, DL, DX, LP, and LV)

### Cabled Models

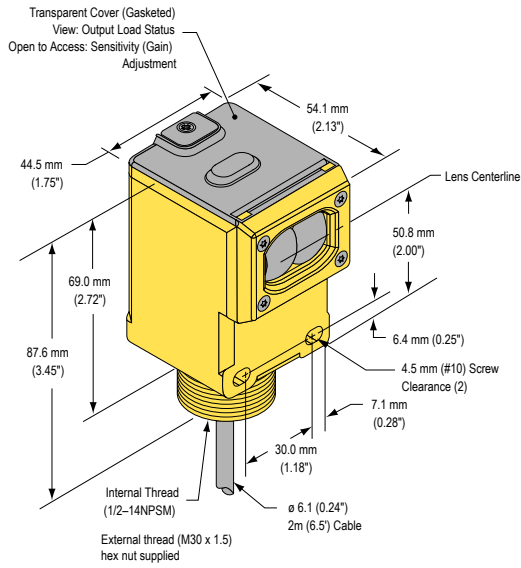

### Quick-Disconnect Models

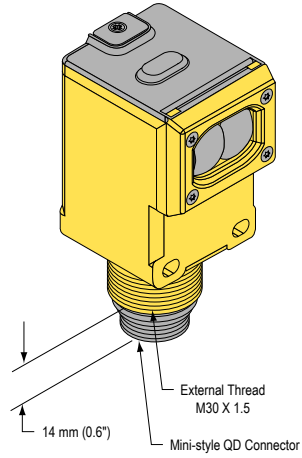

### Convergent Sensor Models

(CV and CV4)

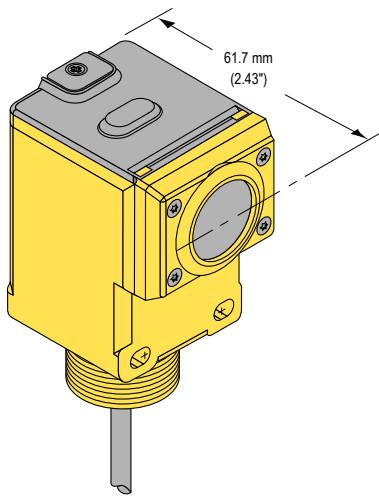

### Glass Fiber Optic Models

(F and FV)

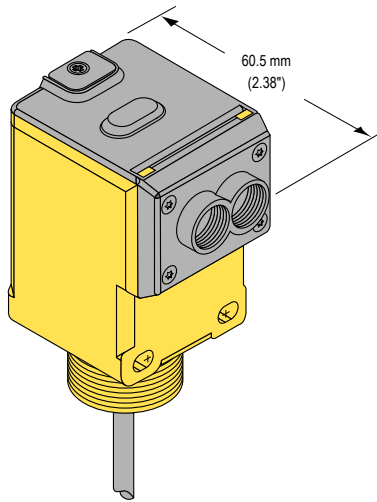

### Plastic Fiber Optic Models

(FP)

