

iVu Plus TG Image Sensor

Instruction Manual

Original Instructions
B_3084219 Rev. D
18 March 2014



Contents

1 Overview of the Sensor	5
1.1 Typical iVu Applications	5
1.1.1 Label Inspection	5
1.1.2 Blister Pack Inspection	6
1.1.3 Vial Stopper Inspection	6
1.2 Installation	6
1.2.1 Components	6
1.2.2 Installing and Connecting the Sensor	8
1.2.3 Cable Connections	10
1.2.4 iVu Trigger, Remote Teach, and I/O Waveforms	12
1.3 Major Features	13
1.3.1 Demo Mode	13
1.3.2 Sensor Types	14
1.3.3 Multiple Sensors	14
1.3.4 Multiple Inspections	15
1.3.5 iVu Plus Communication Summary of Ethernet and Serial	16
1.3.6 Trigger Modes	16
2 Home Screen	18
2.1 Display Mode	18
2.1.1 Image with Annotations	18
2.1.2 Image without Annotations	18
2.1.3 Inspection Statistics	19
3 Main Menu Reference	21
3.1 Main Menu	21
3.2 Inspection Menu	23
3.2.1 Sensors Menu	23
3.2.2 Motion Menu	27
3.2.3 Properties Menu	28
3.2.4 Stored Inspections	29
3.3 Imager Menu	30
3.3.1 Auto Exposure	30
3.3.2 Exposure	31
3.3.3 Gain	31
3.3.4 Trigger	31
3.3.5 Focus	32
3.3.6 Strobe	32
3.3.7 FOV (Field of View)	33
3.4 System Menu	35
3.4.1 Mode	35
3.4.2 System Configuration	35
3.4.3 System Information	36
3.4.4 Lock device	36
3.4.5 Communications	37
3.4.6 Discrete I/O	46
3.4.7 Display Settings	49
3.4.8 Reboot Sensor	50
3.4.9 Firmware Update	50
3.5 Logs Menu	50
3.5.1 Inspection Logs	50
3.5.2 System Logs	52
3.5.3 Communication Logs	52
4 Setting up an Inspection	54
4.1 Acquiring a Good Image	54
5 Configuring Sensors	57
5.1 Sensor Configuration Shortcut Menu	57
5.2 Configuring an Area Sensor	59
5.3 Configuring a Blemish Sensor	62
5.4 Configuring a Match Sensor	65
5.4.1 Remote Teach	68
5.5 Configuring a Sort Application	69
5.6 Configuring Motion	70
5.6.1 Number of Edges	71
5.6.2 Sensitivity	71
5.6.3 Rotation	71

5.7 Configuring Multiple Sensors in the Inspection	71
6 Communications Guide	73
6.1 iVu Plus Communication Summary of Ethernet and Serial	73
6.1.1 Communication Channels	73
6.1.2 Industrial Ethernet	73
6.1.3 Command Channel	73
6.1.4 Data Export	74
6.1.5 Image Export	75
6.2 Enabling Communications	76
6.2.1 Setting Up Ethernet Communications	76
6.2.2 Setting Up Serial Communications	80
6.3 Testing and Troubleshooting iVu Plus Communications	83
6.3.1 Understanding the Communication Log	83
6.3.2 Ethernet I/O	84
6.3.3 Serial I/O	84
6.4 Command Channel Primer	86
6.4.1 Command Channel Commands	86
6.4.2 Conventions Used for Examples	87
6.4.3 Examples	88
6.4.4 Command Channel Reference	88
6.4.5 Multiple Sensors Inspection	95
6.4.6 Command Channel Command Status Register	96
6.4.7 Command Channel Error Codes	96
7 Industrial Ethernet Overview	98
7.1 Device Setup	98
7.1.1 Set IP Address	98
7.1.2 Set Industrial Ethernet Protocol (EIP/Modbus/TCP/PCCC)	98
7.1.3 Set Trigger Mode	98
7.2 Supported Functions	98
7.2.1 iVu Input Values	98
7.2.2 iVu Output Values	99
7.3 Sensor Operation	99
7.3.1 General Command Execution	100
7.4 EtherNet/IP	100
7.4.1 RSLogix5000 Configuration	100
7.4.2 Inputs to iVu (Outputs from PLC)	106
7.4.3 Outputs from the iVu (Inputs to the PLC)	107
7.4.4 Multiple Sensors Mapping Options	110
7.4.5 Input and Output Flags Bits	115
7.4.6 Configuration Assembly Object	116
7.4.7 Data Formats	116
7.4.8 Minimum Requested Packet Interval (RPI) Value	116
7.5 Modbus/TCP	117
7.5.1 Holding Registers	117
7.5.2 Output Registers	117
7.5.3 Multiple Sensors Mapping Options	122
7.5.4 Input and Output Coils	126
7.6 PLC5 and SLC 5 (PCCC)	127
7.6.1 Configuration	127
7.6.2 Inputs to iVu (Outputs from PLC)	129
7.6.3 Outputs from iVu (Inputs to PLC)	129
7.6.4 Multiple Sensors Mapping Options	134
7.6.5 Input and Output Flags	138
7.7 Sample Timing Diagram	139
7.8 Command Channel Command Status Register	142
7.9 Diagnostic Guide	142
7.9.1 Ethernet Diagnostics	142
7.9.2 Networking and TCP/IP Diagnostics	143
7.9.3 Industrial Protocols Troubleshooting	145
7.10 Additional Information	147
7.10.1 iVu Command Channel Commands (iVu Command Channel over Industrial EtherNet)	147
8 Debugging Inspections	152
8.1 iVu Emulator	152
8.2 How to Round-Trip Debug Using the Emulator	152
8.2.1 How to Debug Using the Emulator from a PC	152
8.2.2 How to Debug Using the Emulator from the USB Flash Drive	153
9 Updating the Sensor	154
9.1 Update Process	154
9.2 How to Set or Modify a Device Name	154
9.3 How to Reset the Sensor Password	155

9.4 How to Use Bitmap Image Files with the iVu Emulator	155
10 LED Indicator Troubleshooting	157
10.1 Errors	157
10.2 Warnings	157
11 Product Support and Maintenance	158
11.1 Product Support	158
11.2 Maintenance	158
11.3 Banner Engineering Corp Limited Warranty	159

1 Overview of the Sensor

The iVu Plus TG Series sensor is used to monitor parts for type, size, orientation, shape, and location. No PC is required to configure the sensor. Instead, the sensor has a color touch screen display (either integrated with the sensor or available as a remote display) that you can use to set up and monitor inspections. The following features are available:

- Self-contained image sensor; no PC required
- Easy configuration: install/connect iVu, select sensor type, acquire image, set inspection parameters
- Intuitive interface and sophisticated features make powerful inspection capabilities simple
- Multiple sensor configuration
- GUI available in multiple languages (English, French, German, Italian, Spanish, Japanese, Simplified Chinese, Portuguese, and Turkish)
- 68.5 mm (2.7 in) touch-screen LCD display or separate touch screen display that mounts remotely from the sensor to allow easy access to the user interface and to view inspection images
- Four sensor types in one package—a match sensor that determines whether a pattern on a label or part matches a reference pattern; a sort sensor that can recognize and sort up to ten different patterns within the same inspection; an area sensor that detects whether or not a particular feature (or features) is present; and a blemish sensor that detects flaws on parts
- Robust IP67 housing with integrated lighting (red, blue, green, or infrared)
- M12 connector with 10 to 30 V dc for power supply and PNP or NPN output
- External trigger input, remote TEACH input, and external strobe output available
- USB port for uploading and downloading of inspections and log files for easy updating and diagnostics
- Software emulator for PC available to evaluate inspections offline based on bitmap images or inspection logs

1.1 Typical iVu Applications

1.1.1 Label Inspection



Figure 1. Label Inspection

A manufacturer packages a number of products in similar packaging and needs a cost-effective way to ensure that only like products are packaged together. Additionally, they want to verify that all the products have labels.

To verify each product, an iVu Series sensor is configured for a Match inspection. An image of a good product package is captured. When the inspection is running, if the sensor detects a package with a different or missing label, the sensor sends a fail output to the line, and the product is rejected.

1.1.2 Blister Pack Inspection



Figure 2. Blister Pack Inspection

Because of tightened federal regulations that make the quality of pharmaceutical packaging increasingly critical, when tablets are inserted into a blister pack, manufacturers need to verify that all the blisters in a pack have been filled with unbroken tablets.

To verify each blister in the pack, use an iVu Series sensor configured for an Area inspection. The sensor inspects each blister pack to make sure that each blister contains an unbroken tablet.

1.1.3 Vial Stopper Inspection

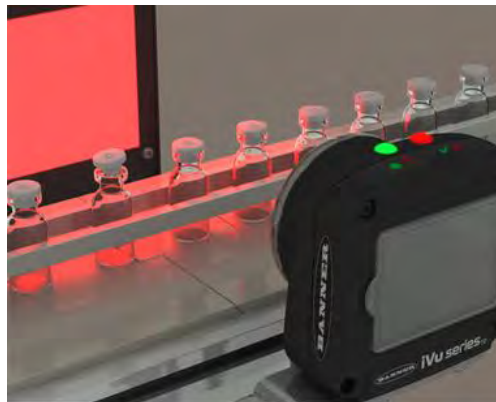

Figure 3. Vial Stopper Inspection

In the pharmaceutical industry where vials are filled with tablets in a high-speed application, as soon as each vial is filled, a stopper must be properly inserted into the vial.

To ensure that a stopper is properly inserted as each vial leaves the filling station, an iVu Series sensor—set up for an Area application and motion parameters enabled—verifies that the vial has a stopper inserted into its neck and that the stopper is positioned correctly to provide a proper seal on the glass vial. If the stopper is missing or incorrectly positioned, then the sensor sends a fail output to the line.

1.2 Installation

1.2.1 Components

iVu with Integrated Display

The iVu Series sensor comes fully assembled with the lens and an integrated ring light if so ordered. The integrated touchscreen display has a plastic cover to protect the display. Remove this cover when setting up the sensor. When the display is not in use be sure to keep the display covered to protect it.

If an integrated ring light is not used, another light source is needed. Various lights are available from Banner. Operating in external trigger mode requires a triggering source (for example, the Banner WORLD-BEAM® QS18VN6D sensor).



- 1 LED - Green: Ready; Red: Error
- 2 LED - Green: Pass; Red: Fail
- 3 Ethernet I/O LED
- 4 Focusing Window
- 5 Focusing Window Locking Clip
- 6 Integrated Display

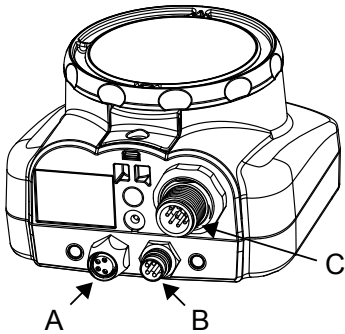

- A 8-pin Euro-style (M12) female USB Cable Connector
- B I/O Cable Connector
- C 12-pin Euro-style (M12) male Power and I/O Cable Connector

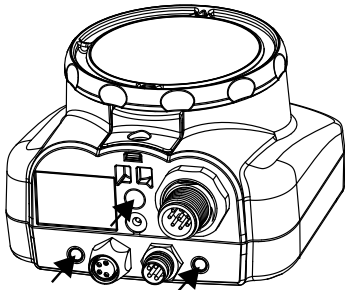

Mounting Bracket Mounting Holes (uses supplied three M4 x 4 mm screws)

iVu with Remote Display

The iVu sensor for use with a Remote Display comes fully assembled with the lens and an integrated ring light if so ordered. Although the Remote Display is not required for normal sensor operation, it is needed to set up the sensor and to monitor inspections.

If an integrated ring light is not used, another light source is needed. Various lights are available from Banner. Operating in external trigger mode requires a triggering source (for example, the Banner WORLD-BEAM® QS18VN6D sensor).



- 1 LED - Green: Ready; Red: Error
- 2 LED - Green: Pass; Red: Fail
- 3 Ethernet I/O LED
- 4 Focusing Window
- 5 Focusing Window Locking Clip

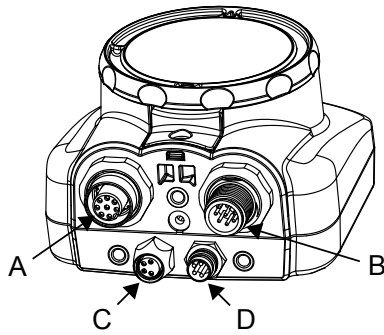

- A Remote Display connector
- B Power and I/O Cable connector
- C USB connector
- D Ethernet connector

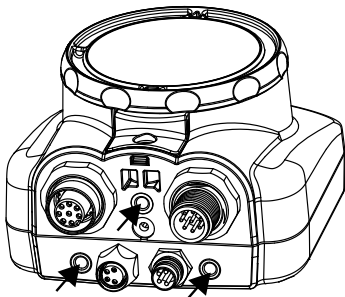

Mounting Bracket Mounting Holes (uses supplied three M4 x 4 mm screws)

1.2.2 Installing and Connecting the Sensor

The iVu Plus TG sensor requires a bracket for mounting. Three brackets are available from Banner. The brackets allow the sensor to be mounted either perpendicular to the part or at an adjustable angle.

Thread three M4 x 4mm screws through the bracket into the mounting holes in the bottom of the sensor. Tighten all three screws.

Table 1: iVu Brackets

SMBI VURAL	SMBI VURAR	SMBI VUU
		

Installing a Filter on iVu Series Sensors

Installing a Filter on the Micro Video Lens Model

To install a filter on the iVu Series sensor with Micro Video Lens, use the illustration as a guide and follow the steps listed below.



CAUTION: Failure to follow these instructions may cause damage to your iVu Series sensor.

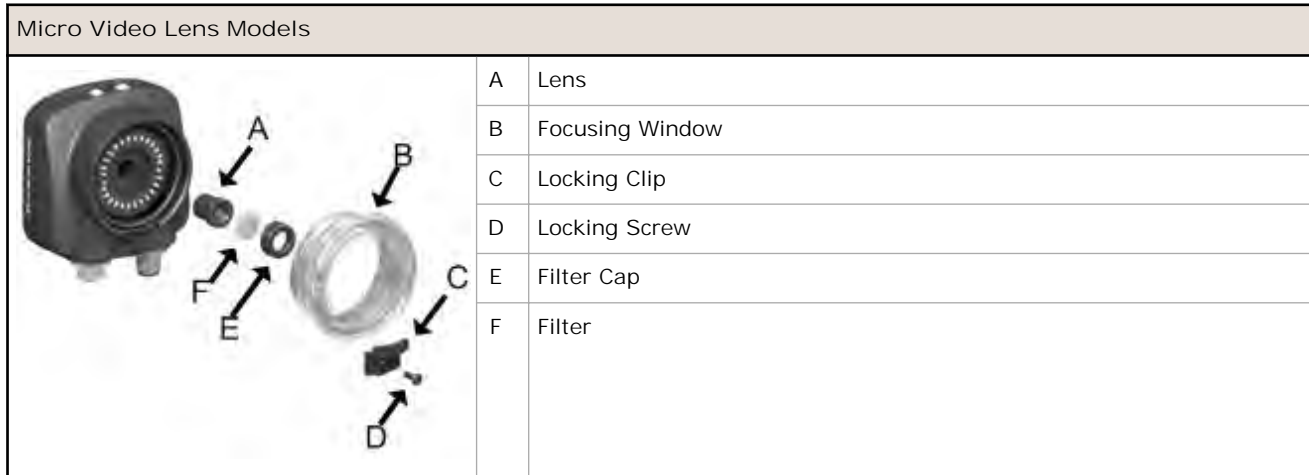

1. Remove the Focusing Window locking screw (D) using the 1/16 in. hex key.



NOTE: The Locking Clip (C) inserts in a groove near the top of the Focusing Window (B). When removing the window, the Locking Clip will be loose. Be careful not to lose the clip while removing the window.

2. Unscrew the Focusing Window by turning it clockwise approximately 5 complete turns or until the Focusing Window disengages from the light/lens assembly.



NOTE: The light/lens assembly may include an integrated ring light or a blank disk if an integrated ring light is not used. Be careful that the light/lens assembly does not pull out when removing the Focusing Window. Give a slight tug on the Focusing Window when you think you've unscrewed it far enough. If the lens assembly moves with the window, continue to rotate the window clockwise until the lens assembly does not move.

3. Set the Focusing Window aside. Be careful not to get any debris on the window's O-ring.
4. If present, remove the protective covering on the filter.
5. Place the filter into the Filter Cap and press the cap onto the lens.
6. After the filter is installed, place the Focusing Window back into the housing while inserting the Locking Clip into the groove as shown.

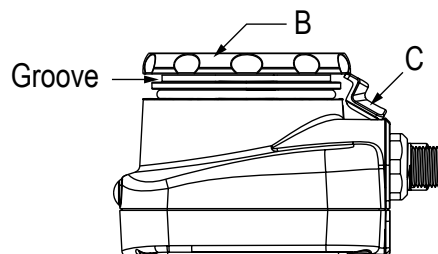

7. Press the Focusing Window onto the housing to make sure that it seats correctly (no gap between the window and housing). Rotate the window counter-clockwise at least two turns.
8. Replace the locking tab screw but do not tighten until you have set up and focused the sensor again.

Installing a Filter on the C-Mount Lens Model

To install a filter on the iVu Series sensor with C-Mount Lens, use the illustration as a guide and follow the steps listed below.



CAUTION: Failure to follow these instructions may cause damage to your iVu Series sensor.

C-Mount Lens Models	
	A C-Mount Lens
	B Lens Enclosure
	C Retainer Ring (optional)
	D Filter (optional)
	E Filter Retainer Ring Tool
<p>NOTE: Filter Kits are available separately.</p>	

1. Remove the Lens Enclosure and Lens.
2. Install filter behind the retainer ring. Make sure it is fully seated.
3. Using the provided retainer ring tool, thread the retainer ring into the sensor until it firmly seats the filter.
4. Replace the Lens and Lens Enclosure on the camera.



CAUTION: Electrostatic Discharge

Avoid the damage that electrostatic discharge (ESD) can cause to the Sensor.

Always use a proven method for preventing electrostatic discharge when installing a lens or attaching a cable.

1.2.3 Cable Connections

Cable Connections for Integrated Display

The cable connections on the iVu Plus with integrated display are shown below, and power I/O connections (C) are defined in the Power I/O Connections table below.

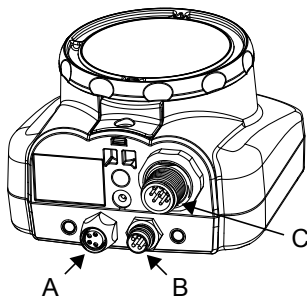

- A USB Connector
- B Ethernet Connector
- C Power I/O Connector



NOTE: Micro video lens model shown, C-Mount model connections are identical.

Power I/O Connections			
Pin #	Wire Color	Description	Direction
1	White	Output 1	Output
2	Brown	10-30V dc	Input
3	Green	Output 2	Output
4	Yellow	Strobe Out (5V dc only)	Output
5	Gray	Remote Teach	Input
6	Pink	External Trigger	Input
7	Blue	Common (Signal Ground)	Input
8	Red	Ready	Output
9	Orange	Output 3	Output
10	Light Blue	RS-232 TX	Output
11	Black	RS-232 Signal Ground	Output
12	Violet	RS-232 Rx	Input

Cable Connections for Remote Display

The cable connections on the iVu Plus with remote display are shown below, and power I/O connections (B) are defined in the Power I/O Connections table below.

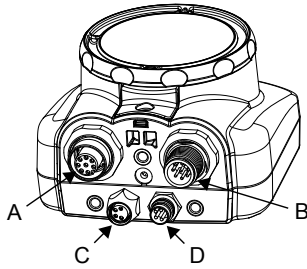

- A Remote Display Connector
- B Power I/O Connector
- C USB Connector
- D Ethernet Connector



NOTE: Micro video lens model shown, C-Mount model connections are identical.

Power I/O Connections			
Pin #	Wire Color	Description	Direction
1	White	Output 1	Output
2	Brown	10-30V dc	Input
3	Green	Output 2	Output
4	Yellow	Strobe Out (5V dc only)	Output
5	Gray	Remote Teach	Input
6	Pink	External Trigger	Input
7	Blue	Common (Signal Ground)	Input
8	Red	Ready	Output
9	Orange	Output 3	Output
10	Light Blue	RS-232 TX	Output
11	Black	RS-232 Signal Ground	Output
12	Violet	RS-232 Rx	Input

1.2.4 iVu Trigger, Remote Teach, and I/O Waveforms

The iVu has two input signals—Trigger and Remote Teach. The default setting is to detect the low to high transition. This setting can be changed in the Main Menu > System > Discrete I/O > Input Polarity screen on the sensor.

PNP (Low-to-High) Trigger and Remote Teach Input Waveforms

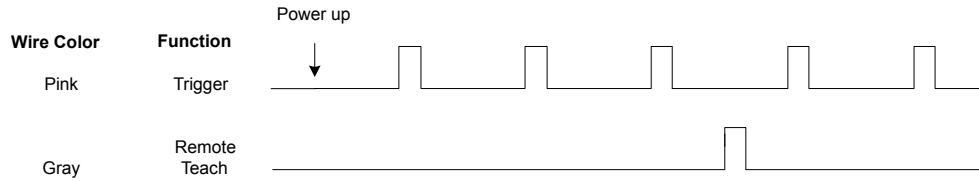

The sensor triggers from low to high, and Remote Teach behaves electrically like trigger.

NPN (High-to-Low) Trigger and Remote Teach Input Waveforms

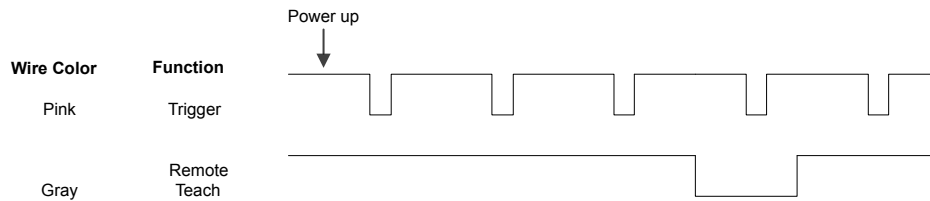

The sensor triggers from high to low, and Remote Teach behaves electrically like trigger.



NOTE: If the device used to trigger or remote teach the iVu Plus TG is a sinking device, these are the options regarding the use of a pull-up resistor:

Option 1: Put a pull-up resistor, rated approximately 1k ohm, between the sensor's positive (+) voltage and the sensor's input as shown below.

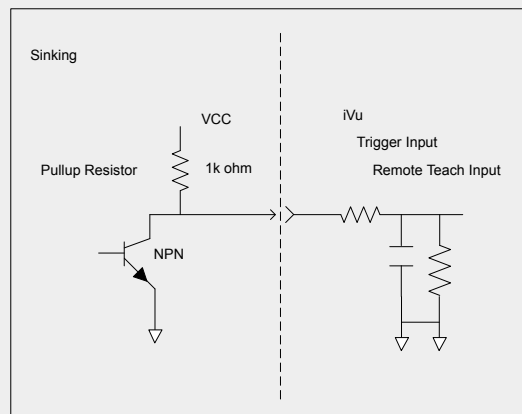

Option 2: Enable the Input Pullup in the iVu Plus TG software (Main Menu > System > Discrete I/O > Input Pullup).

iVu Output Waveforms

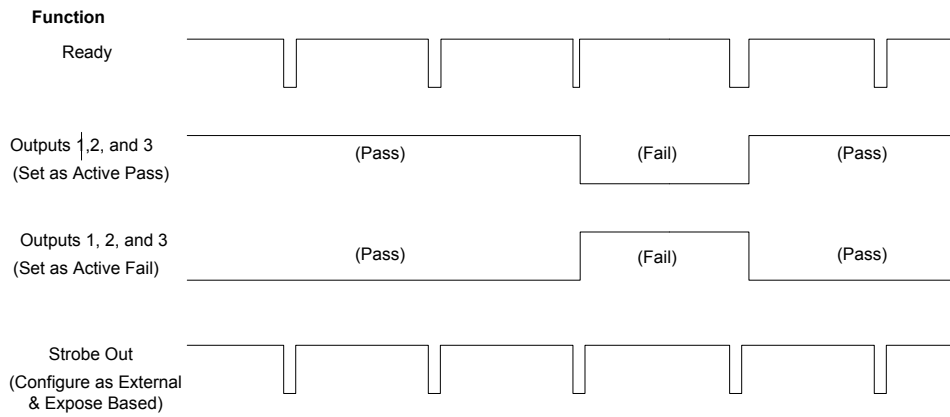

Figure 4. PNP Outputs

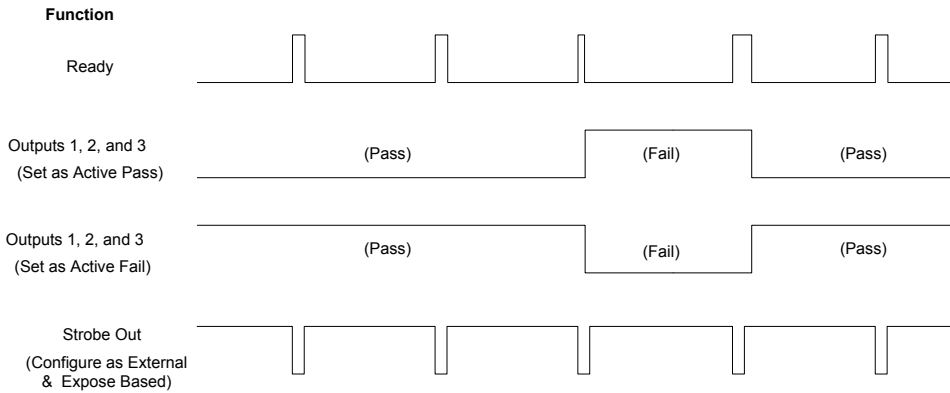
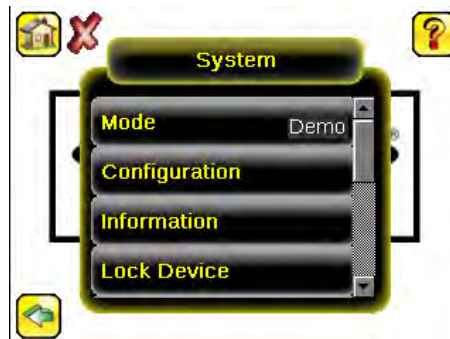

Figure 5. NPN Outputs

1.3 Major Features

1.3.1 Demo Mode

The first time you power up the iVu Plus TG sensor, it starts in Demo Mode. Demo Mode uses stored images and inspection parameters that demonstrate how the sensor is set up without having to worry about focus, lighting, or triggers. In this mode, you can learn how to make adjustments while working with the different sensor types and observing how the adjustments affect the sensor results. To exit Demo Mode, go to Main Menu > System > Mode and select Live from the drop-down list. When you exit Demo Mode, the sensor reboots into its normal operating mode with default settings.





NOTE: Switch between Live Mode and Demo Mode any time by going to Main Menu > System > Mode.

1.3.2 Sensor Types

The iVu Plus TG sensor includes four Sensor Types:

- Area Sensor
- Blemish Sensor
- Match Sensor
- Sort Sensor

Area Sensor

An Area type sensor is used to ensure that a feature, or multiple features, are present on a part. When setting up the sensor for an Area inspection, a feature, such as a drilled hole, is identified as well as the size (area) expected. If there is more than one of the identified features on a part, the number expected can be set as well. During the inspection, the sensor verifies that each part or package includes the specified number of features. Some example applications include:

- Inspections that check for drilled holes on a part
- Inspections that check for correctly stamped parts
- Inspections that ensure proper packaging (for example, check that a packing slip exists in or on a box; test whether a vial is properly capped)
- Inspections of blister packs

Blemish Sensor

A Blemish type sensor can be used to find flaws on a part (for example, scratches on a disc), or it can be used to make sure a feature exists on a part. Although verifying a feature is present on a part is more commonly an Area sensor application, a Blemish sensor may be a better option when dealing with variable materials or uneven lighting. Some example applications include:

- Inspections that check for scratches on a part, and reject parts where the scratches are too numerous or larger than acceptable
- Inspections that check for the presence of some label or marking on a part that may vary in color

Match Sensor

A Match type sensor is used to verify that a pattern, shape, or part in any orientation matches a reference pattern. The reference pattern is taught during setup. A reference pattern might include alphanumeric characters, logos, or any other shapes. During an inspection, the sensor checks that each part or package being inspected matches the reference pattern. Additionally, if there is more than one of the identified pattern, the number expected can be set.

Some example applications include:

- Date/Lot code inspections
- Label inspections
- Part etching inspections
- Part orientation inspections
- Part shape inspections

Sort Sensor

A Sort sensor type that can recognize and sort up to ten different patterns within the same inspection. Each reference pattern is taught during setup and stored in one of ten pattern memory locations. A reference pattern might include alphanumeric characters, logos, or any other shapes, and the pass criteria can be set for any or all of the patterns.

Some example application include:

- Identify and sort parts on a production line
- Ensure that several different parts are present in a package

1.3.3 Multiple Sensors

Firmware versions 1.2.0 and newer include multiple sensor functionality. Each part inspected can now use multiple sensors to inspect more than one feature. Up to 30 such inspections can be created and stored on the device.

1.3.4 Multiple Inspections

The iVu Plus supports multiple inspections that facilitate storing and controlling up to 30 inspections of different Sensor Types.

Adding a New Inspection

To Add a new stored inspection:

1. Go to Main Menu > Inspection > Stored Inspections and click Add New.

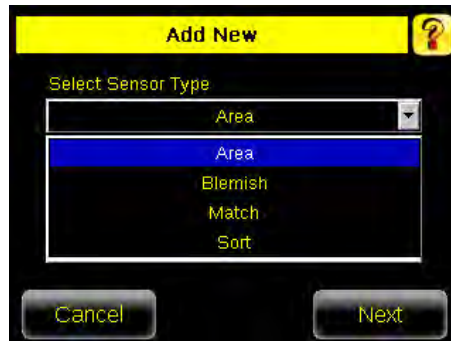

2. Select the Sensor Type for the new inspection, and click Next.



3. Click Done. The newly created inspection will now be the current inspection.

Changing Running Inspections

To change the running inspection:

1. From the Home screen, click the Yellow button in the top center of the screen that displays the currently running inspection to display all the stored inspections.



2. Select the inspection to start and click the Start Running button that appears below it.



1.3.5 iVu Plus Communication Summary of Ethernet and Serial

The iVu Plus communicates with other devices via Ethernet or a UART serial communications port (RS-232). In order to establish an Ethernet connection to the sensor, the external device must be configured with the correct IP address and TCP port to communicate. To use the serial communications connection, port settings for baud rate, data bits, parity, and stop bits must be configured on the iVu Plus to match the settings of the external device.

Communication Channels

The iVu Plus TG supports up to four communications channels. To access the channels, go to Main Menu > System > Communications.



- Command Channel—a bi-directional communication protocol that currently supports ASCII and enables other devices to remotely control the iVu Plus sensor and access sensor results
- Industrial Ethernet—a bi-directional communication channel that allows the user to control the sensor and access sensor results using Ethernet/IP, Modbus/TCP, or PCCC protocol
- Data Export—used to export selected inspection data to a remote device
- Image Export—used to export inspection images to a remote device

Data export and command channel can be configured for either Ethernet or Serial I/O (but not both); image export is only available over Ethernet. The table below briefly summarizes valid communication channel configuration options.

Command Channels	Scenario #1		Scenario #2		Scenario #3	
	Ethernet	Serial I/O	Ethernet	Serial I/O	Ethernet	Serial I/O
Command Channel	Yes	No	No	Yes	Yes	No
Industrial Ethernet	Yes	No	Yes	No	Yes	No
Data Export	Yes	No	Yes	No	No	Yes
Image Export	Yes	No	Yes	No	Yes	No

1.3.6 Trigger Modes

The iVu Plus TG has five trigger modes that determine how the sensor captures and processes images:

- External
- Internal

- Free Run
- Industrial Ethernet Only
- Command

Select one of the trigger modes by accessing Main Menu > Imager > Trigger on the iVu touch screen display. [Trigger](#) on page 31 describes these trigger modes in more detail.

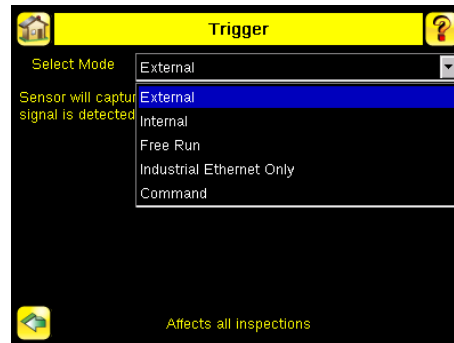

2 Home Screen

The Home screen on the iVu Series sensor display is used to monitor inspections and to configure the sensor. Normally, the part being inspected is centered on the screen with the feature of interest bounded by the Region of Interest (ROI), a rectangle as shown below. The ROI can be rotated and resized, and is highlighted when selected for adjustment.

In the following graphic, there are 2 ROI because it is a multi sensor inspection. The green annotations indicate the object passes, and the red annotations indicate a failure. This sample inspection failed as shown by the red X next to the Display mode button.

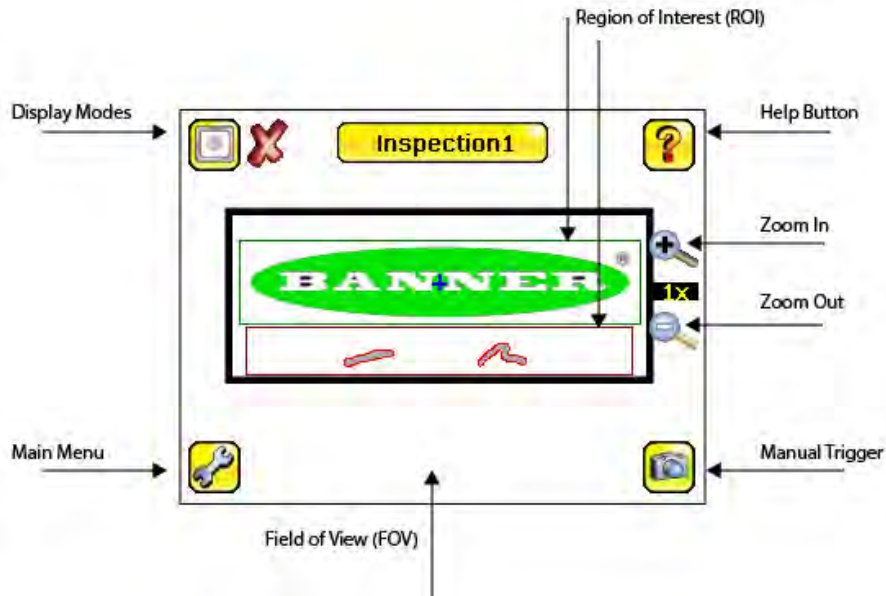

2.1 Display Mode

Main Menu > Home > Display Mode (icon)

Use the display mode button on the upper left corner of the screen to cycle through all three display modes. The 3 display modes include: Image with Annotations, Image without Annotations, and Inspection Statistics.

2.1.1 Image with Annotations

Click the display mode icon  to show the image with the annotations on. The green or red areas indicate sensors that pass or fail in the ROI.



2.1.2 Image without Annotations

Click the  display mode icon to see the image without the annotations from the sensors.



2.1.3 Inspection Statistics

To access the Inspection Statistics, click the Display mode icon .

The Inspection Statistic mode has three pages:

- History
- Inspection Result
- Inspection Inputs

Click the arrows to access the other pages.

Inspection Results

The Inspection Result screen shows data about the current inspection being viewed.

The table contains result of each sensor in the inspection. To view details of each sensor, click on the + icon. If a sensor fails, its box will be drawn in RED. An icon besides the sensor name indicates the reason of its failure.

Inspection Result		
Blotch1	1	0
Count (pix)	2489	
Edge Length Range	(38, 527)	
Time (ms)	N/A	
Match1	0	1
Inspection1	0	1

History

The History screen shows inspection history from sensor reboot, or the last time the statistics were reset, including:

- Total Frames—Total number of objects counted
- Passed—running total of parts that passed inspection
- Failed—running total of parts that failed inspection
- Missed triggers—running total of missed triggers
- Time Range—minimum and maximum inspection times observed

Click the Reset button to reset statistics.

The table contains history of each sensor in the inspection. Data of each sensor can be expanded or collapsed as required using the +/- . The green area indicates the sensor passed, red indicates fail. If a sensor fails, an icon besides the sensor name will indicate the reason of failure.



Inspection Inputs

The Inspection Input page has the sensor settings. Use this page to verify what inspection input settings were used on the latest inspection. Click + to expand the inspection information, or – to collapse the inspection information. Use the right arrows as a shortcut go to a sensor setting screen.

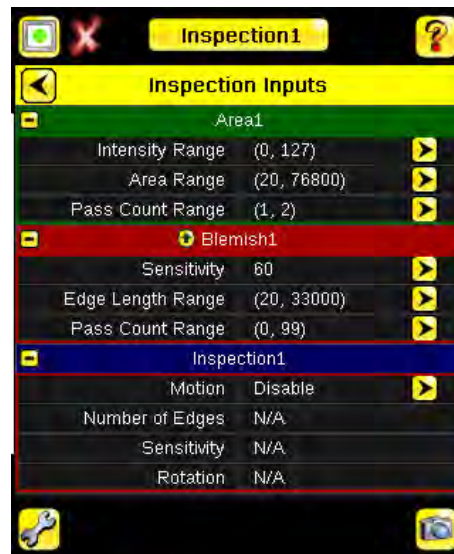

3 Main Menu Reference

3.1 Main Menu

The Main Menu has four sections:

Inspection - to modify inspection settings

Imager - to run the Auto Exposure routine and to make adjustments to functions like exposure, gain, and strobe

System - to select the sensor Type and to manage the device

Logs - to configure and view System and Inspection Logs

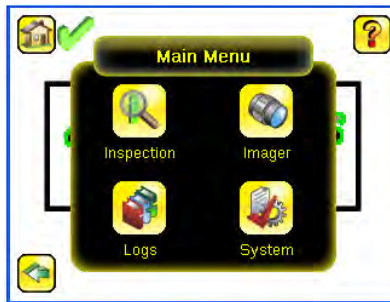

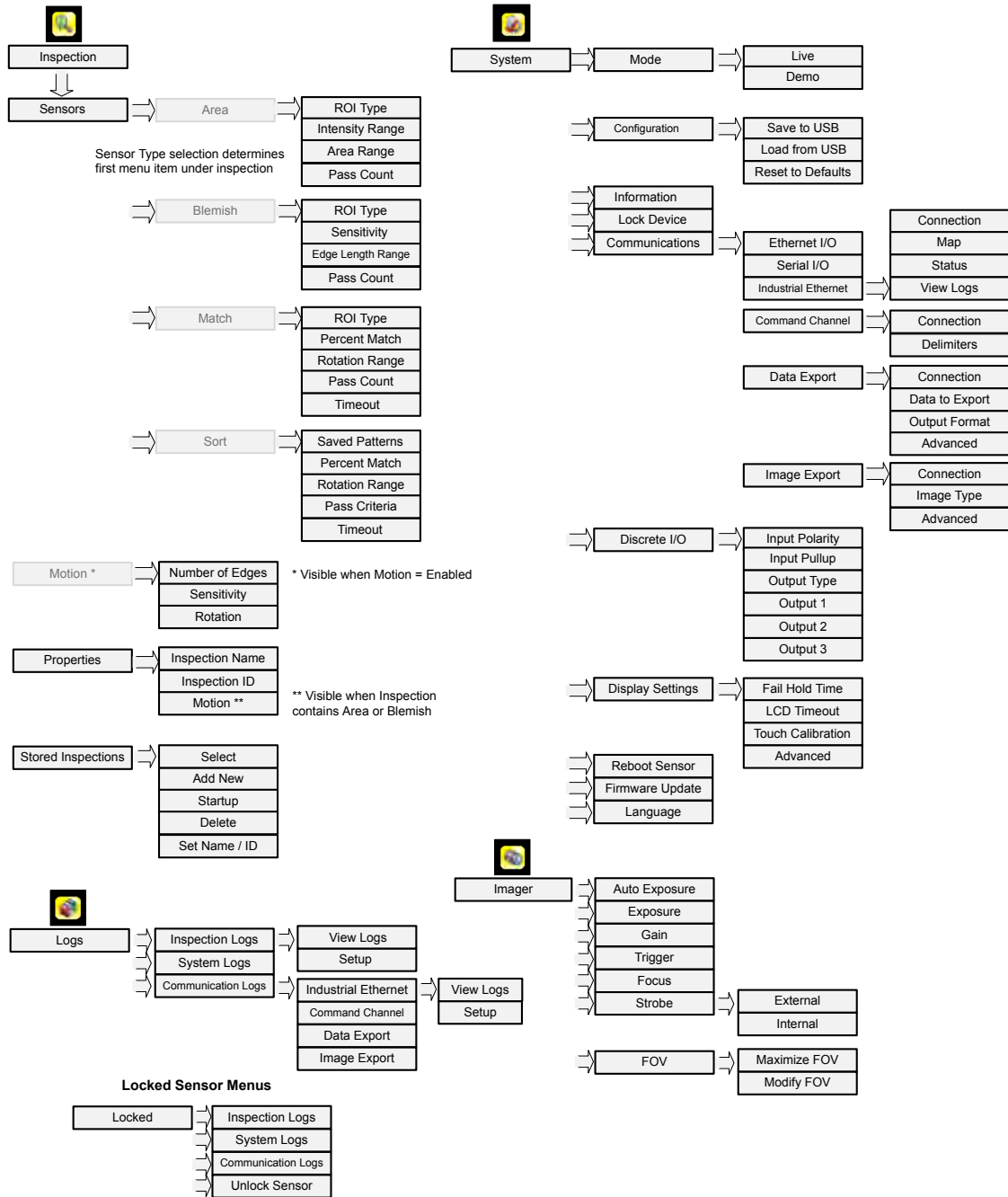

3.2 Inspection Menu

Main Menu > Inspection

The Inspection menu icon is located on the Main Menu and is where settings for inspection can be adjusted. Each type of sensor has specific settings that are available. It is also where stored inspections can be managed.

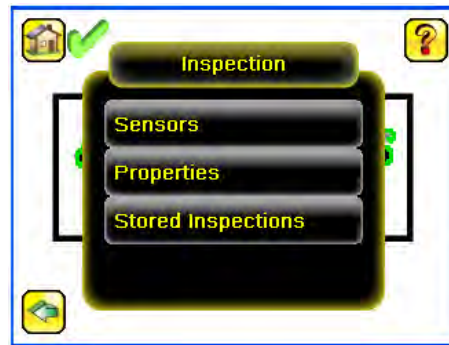

3.2.1 Sensors Menu

Main Menu > Inspection > Sensors

This menu shows the list of sensor(s) that are included in the current inspection. Use the Add Sensor button add a new sensor into the current inspection.



Area Menu

Main Menu > Inspection > Sensors > Area

When configured as an Area sensor, the sensor is used to ensure that one or more features of interest are present on a part. To configure as an Area sensor, set four parameters:

- ROI Type (Rectangle, Elliptical, or Circle) and size
- Intensity Range (range of gray scale values) of a feature of interest
- Area Range, or size, of a feature of interest
- Pass Count

To see a working example of the sensor configured as an Area sensor, see Demo Mode.

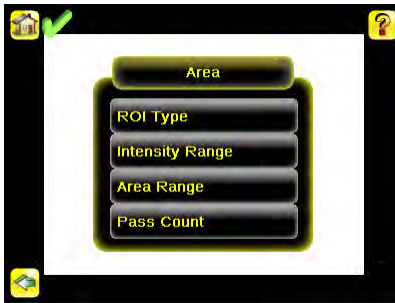

ROI Type

Main Menu > Inspection > Sensors > Area > ROI Type

The Region of Interest (ROI) is the user-defined area on the screen that the sensor will analyze. The ROI Type can be rectangular, elliptical, or circular. From the menu at the bottom of the ROI Type screen, select the ROI Type to use for the inspection. Adjust the ROI as appropriate for your inspection. An ROI can be as large as the entire Field of View (FOV).

Intensity Range

Main Menu > Inspection > Sensors > Area > Intensity Range

Intensity Range is the range of gray scale values the sensor should look for. To set the Intensity Range, use the eye dropper on the left of the screen to select the target feature, then use the slider bar at the bottom of the display to fine tune the selection. As the slider bar is moved, green highlighted areas indicate objects the sensor finds.



NOTE: Objects that are colored yellow are found, but filtered out. This is because the objects fall outside of the Area Range. See Area Range to adjust this setting.

Area Range

Main Menu > Inspection > Sensors > Area > Area Range

The Area Range is used to set the size limits of a feature of interest. Use the slider bar at the bottom of the display to select the range. Areas are measured by counting pixels. For example, a rectangular feature that is 100 pixels wide by 200 pixels tall will have an area of roughly 20,000 pixels.

Pass Count

Main Menu > Inspection > Sensors > Area > Pass Count

The Minimum Pass Count is the minimum number of parts, labels, or features expected to fall within the specified criteria; the Maximum Pass Count is the maximum number expected to fall within the specified criteria. These settings are used to determine the pass or fail result of the inspection.

Blemish Menu

Main Menu > Inspection > Sensor > Blemish

When configured as a Blemish sensor, it can be used to find flaws on a part (for example, scratches on a disc). It can be used to make sure the a feature exists on a part. Although this is more commonly an application for a sensor configured as an Area sensor, a Blemish sensor may be a better option to find a feature when dealing with variable materials or uneven lighting. Some sample applications include:

- Inspections that check for scratches on a part, and reject parts where the scratches are too numerous or larger than acceptable
- Inspections that check for the presence of some label or marking on a part that may vary in color

To configure as a Blemish sensor, select the ROI type, and set the Sensitivity, Size Filter, and Pass Count.

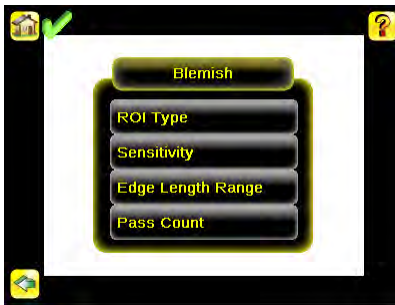

ROI Type

Main Menu > Inspection > Sensors > Blemish > ROI Type

The Region of Interest (ROI) is the user-defined area on the screen that the sensor will analyze. The ROI Type can be rectangular, elliptical, or circular. From the menu at the bottom of the ROI Type screen, select the ROI Type to use for the inspection. Adjust the ROI as appropriate for your inspection. An ROI can be as large as the entire Field of View (FOV).

Sensitivity

Main Menu > Inspection > Sensors > Blemish > Sensitivity

Sensitivity is used to fine-tune how sensitive the sensor is to finding blemish or other edges within the ROI. The Sensitivity value helps account for light variations that might affect how well the sensor detects edges on inspected parts. The Sensitivity scale is from 0 to 100 where 0 means least sensitive and 100 means most sensitive. If set near 0, the sensor will only find very sharp edges with strong contrast. If set near 100, the sensor will find very dim or blurry edges, and may be unstable.

Edge Length Range

Main Menu > Inspection > Sensors > Blemish > Edge Length Range

The sensor counts all the edge pixels it detects in the ROI. The bar at the bottom of the Edge Length Range screen shows all the different contiguous edge segments found. Edge segments within the two brackets [] are highlighted in green and those outside the brackets are ignored and colored yellow. Use the slider bar to specify the edge length range in pixels. Edges found within this range will be considered to calculate the Pass Count.

Pass Count (Pixels)

Main Menu > Inspection > Sensors > Blemish > Pass Count

The Minimum Pass Count is the minimum number of pixels expected to fall within the specified criteria; the Maximum Pass Count is the maximum number of pixels expected to fall within the specified criteria. These settings are used to determine the pass or fail result of the inspection.

Match Menu

Main Menu > Inspection > Sensors > Match

When the sensor is configured as a Match sensor, set the ROI Type, Percent Match, Rotation Range, Pass Count, and Timeout for the inspection. To see a working example of the sensor configured as a Match sensor, see Demo Mode.

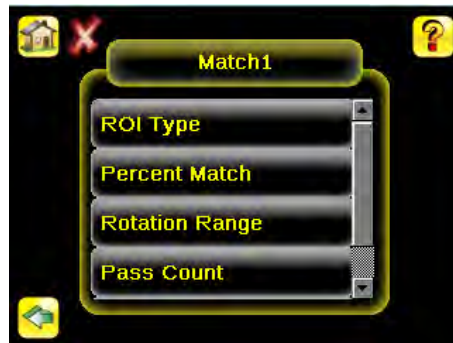

ROI Type

Main Menu > Inspection > Sensors > Match > ROI Type

Sensors The Region of Interest (ROI) is the user-defined area on the screen that the sensor will analyze. The ROI Type can be rectangular, elliptical, or circular. From the menu at the bottom of the ROI Type screen, select the ROI Type to use for the inspection. Adjust the ROI as appropriate for your inspection. An ROI can be as large as the entire Field of View (FOV).

Percent Match

Main Menu > Inspection > Sensors > Match > Percent Match

The Percent Match setting adjusts for how closely the inspected part or label matches the reference part or label. The Percent Match scale is from 0 to 100 where 0 is the most tolerant and 100 is the least tolerant. Move the slider to the left or to the right.

Rotation Range

Main Menu > Inspection > Sensors > Match > Rotation Range

The Rotation Range sets the expected rotation of parts or labels during an inspection. For example, a value of 45 means that the part may rotate 45 degrees in either direction from the reference part and still pass. Move the slider from 0 to 180 degrees.



NOTE: The smaller the rotation range, the faster the inspection will run.

Pass Count

Main Menu > Inspection > Sensors > Match > Pass Count

The Minimum Pass Count is the minimum number of parts, labels, or features expected to fall within the specified criteria; the Maximum Pass Count is the maximum number expected to fall within the specified criteria. These settings are used to determine the pass or fail result of the inspection.

Timeout

Main Menu > Inspection > Sensors > Match > Timeout

When the sensor type is set as Match or Sort, this screen provides for adjusting the maximum time the inspection is allowed to execute. A timeout error is reported in the case inspection runs out of time. If this value is set too high, the sensor can miss triggers while trying to detect a bad pattern.

Sort Menu

The Sort sensor is used to identify and sort up to 10 stored patterns. The menu items in the Sort sensor provide for managing stored patterns and configuring Sort sensor inspection parameters.

The Sort sensor cannot be added if any other sensors are selected. The Sort menu can only be reached when adding a sensor.

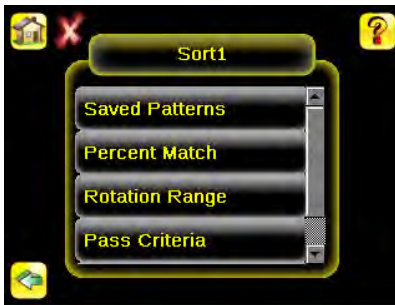

Saved Patterns

Main Menu > Inspection > Sensors > Sort > Saved Patterns

When configuring a Sort sensor type, there are 10 pattern storage locations available. The Saved Patterns screen is used to save a taught pattern to an empty pattern storage location or to overwrite an existing pattern. This screen is also where patterns can be deleted from a storage location, named, or renamed.

Percent Match

Main Menu > Inspection > Sensors > Sort > Percent Match

The Percent Match setting adjusts for how closely the inspected part or label matches the reference part or label. The Percent Match scale is from 0 to 100 where 0 is the most tolerant and 100 is the least tolerant. Move the slider to the left or to the right.

Rotation Range

Main Menu > Inspection > Sensors > Sort > Rotation Range

The Rotation Range sets the expected rotation of parts or labels during an inspection. For example, a value of 45 means that the part may rotate 45 degrees in either direction from the reference part and still pass. Move the slider from 0 to 180 degrees.



NOTE: The smaller the rotation range, the faster the inspection will run.

Pass Criteria

Main Menu > Inspection > Sensors > Sort > Pass Criteria

There are four options to select from to define pass criteria for a Sort sensor inspection, which are described below using an example where there are two saved patterns.

- Any Saved Pattern—Pass condition if the sensor matches either Pattern_1, Pattern_2, or both
- All Saved Patterns—Pass condition if the sensor matches both Pattern_1 AND Pattern_2
- Single Saved Pattern—Pass condition if the sensor matches either Pattern_1 OR Pattern_2, but NOT both
- Specific Saved Pattern (requires selecting a saved pattern to match; for example, Pattern_2) - Pass condition when the sensor matches only Pattern_2

Timeout

Main Menu > Inspection > Sensors > Sort > Timeout

When the sensor type is set as Match or Sort, this screen provides for adjusting the maximum time the inspection is allowed to execute. A timeout error is reported in the case inspection runs out of time. If this value is set too high, the sensor can miss triggers while trying to detect a bad pattern.

3.2.2 Motion Menu

Main Menu > Inspection > Motion

Enable Motion when the part is expected to move or rotate. Motion settings also involve selecting the number of edges to locate, adjusting sensitivity, and selecting whether or not rotation is enabled. These settings appear on the Inspection Menu after Motion is set to 'Enabled'. Motion is enabled when Area and/or Blemish sensor are included in the inspection.

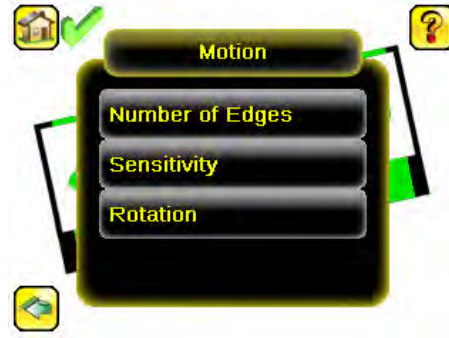

Number of Edges

Main Menu > Inspection > Motion > Number of Edges

On the Number of Edges screen, use the radio buttons to select One Edge or Two Edges. If One Edge is selected, motion is tracked in one direction (by default, horizontally); if Two Edges is selected, motion can be tracked horizontally and vertically.

Sensitivity

Main Menu > Inspection > Motion > Sensitivity

Sensitivity is used to fine-tune how sensitive the sensor is to finding a reference edge. The Sensitivity value helps account for light variations that might affect how well the sensor detects edges on inspected parts. The Sensitivity scale is from 0 to 100 where 0 means least sensitive and 100 means most sensitive. If set near 0, the sensor will only find very sharp edges with strong contrast. If set near 100, the sensor will find very dim or blurry edges, and may be unstable due to noise within the image.

Rotation

Main Menu > Inspection > Motion > Rotation

Rotation can be Enabled or Disabled. Select Enabled if the part can be expected to rotate during the inspection.

3.2.3 Properties Menu

Main Menu > Inspection > Properties

The Properties menu is used to select a Sensor Type and specify an Inspection Name. Additionally, if the Sensor Type is Match or Sort, an option to define a timeout for the inspection.



Inspection Name

Main Menu > Inspection > Properties > Inspection Name

The Inspection Name screen displays the name of the current inspection. You can edit the name of the inspection here.

Inspection ID

Main Menu > Inspection > Properties > Inspection ID

Click on the dropdown arrow to view a list of IDs assigned to all inspections on this device. Choose any unused ID to change the ID of this inspection. The original ID will be marked as 'Unused'.

You may also swap the ID of this inspection with another inspection by selecting that inspection on the list.

3.2.4 Stored Inspections

Main Menu > Inspection > Stored Inspections

Stored Inspections is used to manage stored inspections. Management of stored inspections includes adding, deleting, and specifying which inspection should be defined as the Startup inspection.



From the Stored Inspections menu click Select, Add New, Startup, Delete, or Set Name/ID

Select

Main Menu > Inspection > Stored Inspections > Select

This screen is used to select a new running inspection. Select the name of the inspection to start, and click the Start Running button that displays.

Add New

Main Menu > Inspection > Stored Inspections > Add New

The Add New button is to add a new inspection. The sensor can store up to 30 inspections. When you add a new inspection, it will begin running. When adding a new inspection, the Sensor Type and inspection name will be set.



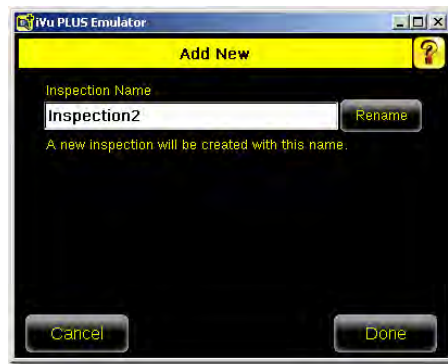

Startup

Main Menu > Inspection > Stored Inspections > Startup

The Startup button allows you to select the inspection to use as the startup inspection. The selected inspection will automatically start after power up.

Delete Inspections

Main Menu > Inspection > Stored Inspections > Delete

The Delete button is used to delete stored inspections. Note that any running inspection, or the inspection marked as the Startup inspection, cannot be deleted.

Set Name/ID

Main Menu > Inspection > Stored Inspections > Set Name/ID

The Set Name/ID button is used to change the name or ID of an inspection. You can sort the inspections in numeric or alphabetical order by clicking on the icon beside the Help icon. Click on Name to edit the name of the inspection. Click on ID to change the ID of the inspection.

3.3 Imager Menu

Main Menu > Imager

The Imager menu icon is on the Main Menu, and lists parameters that affect the characteristics of the captured image. The Imager menu is used to access the Auto Exposure routine, manually adjust Exposure and Gain, set Trigger and Strobe options as well as the size of the field of view (FOV).

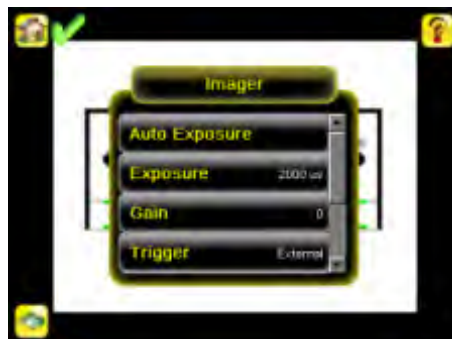

3.3.1 Auto Exposure

Main Menu > Imager > Auto Exposure

Auto Exposure optimizes the exposure time and gain for the current lighting conditions. Multiple triggers are required to complete this function.



NOTE: The Auto Exposure option is not available on the Emulator.

3.3.2 Exposure

Main Menu > Imager > Exposure

Exposure is the amount of time the sensor allows light to energize the imager. Increasing the exposure time by moving the slider to the right allows more light to energize the imager, which brightens the image.

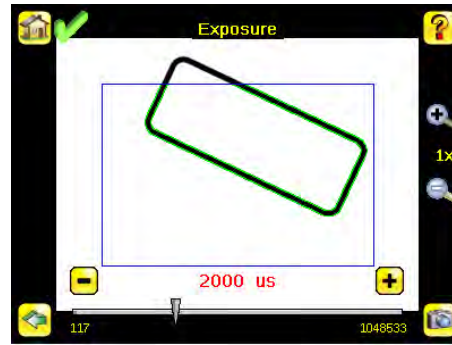

NOTE: This feature is not effective on the emulator.

3.3.3 Gain

Main Menu > Imager > Gain

Gain is an electronic boost to the image signal. Increasing Gain by using the '-' and '+' keys or moving the slider to the right increases image brightness without increasing exposure time. Note that Gain brightens both the light pixels and dark pixels and may reduce the image quality.

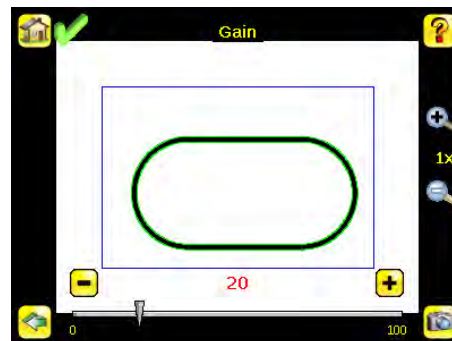

NOTE: This feature is not effective on the emulator.

3.3.4 Trigger

Main Menu > Imager > Trigger

A Trigger is a signal that makes the sensor capture an image and inspect it. Use the radio buttons to select External Trigger, Internal Trigger (default), Free Run, Industrial Ethernet Only, or Command.

- If Internal Trigger is selected, triggers are based on timed intervals, and you need to select a trigger interval between 10 and 10000 milliseconds.



NOTE: If the interval is less than the inspection time, then missed triggers will occur.

- If External Trigger is selected, inspections are triggered in response to an electrical signal on the Trigger input line.
- If Free Run is selected, the sensor automatically runs continuous inspections.
- If Command is selected, the command channel is used to trigger the sensor from a remote device.
- If Industrial Ethernet Only is selected, trigger commands from the Industrial Ethernet communications channel only are accepted.

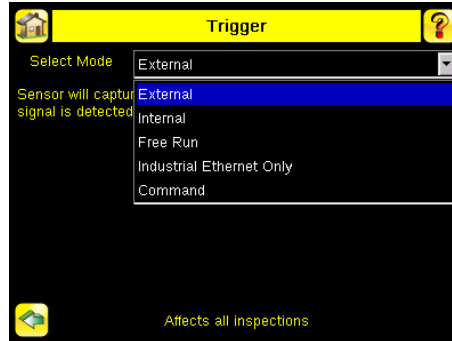

3.3.5 Focus

Main Menu > Imager > Focus

The Focus Number displayed at the bottom of this screen is used to fine-tune image focus. Loosen the lock on the lens cover, turn the focus ring on the sensor until the Focus Number peaks (or the image appears sharp), then lock the focus ring.



NOTE: For the Focus Number to work, the sensor must be triggering and the images must be similar over time.

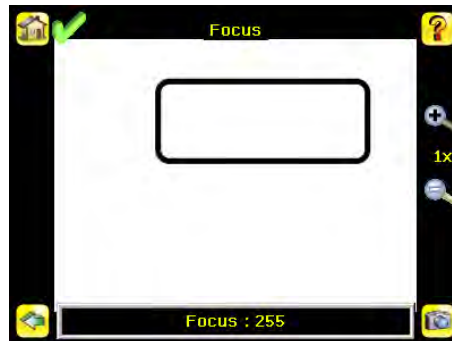

3.3.6 Strobe

Main Menu > Imager > Strobe

The Internal Strobe configures the operation of the integrated ring light. The External Strobe configures the operation of an external light.

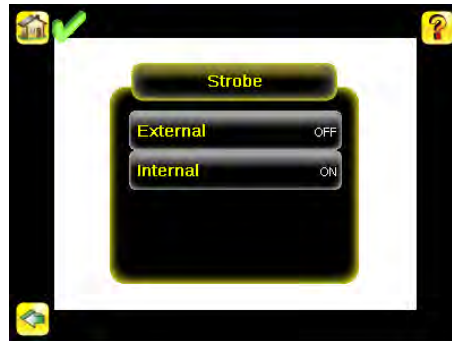

External

Main Menu > Imager > Strobe > External

The External Strobe is a 5V output that can be used for an external light. Setting options are Always ON, Always OFF, or Exposure Based. If Exposure Based is selected, then the external light is on during the time the sensor is capturing an image.

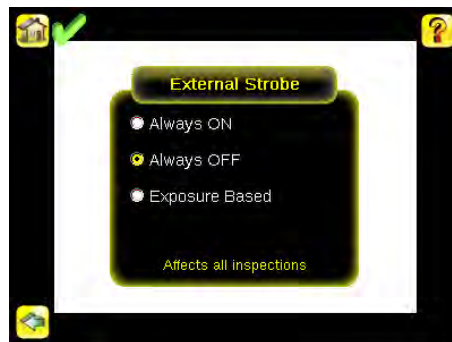

Internal

Main Menu > Imager > Strobe > Internal

The Internal Strobe setting configures the operation of the integrated ring light. Strobe options are Always ON, Always OFF, or Exposure Based. If Exposure Based is selected, then the ring light is on during the time the sensor is capturing an image. For UV models, the Always ON option is not available.

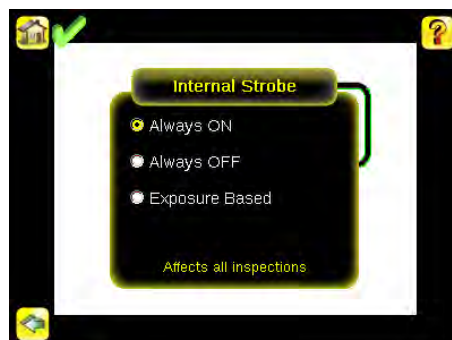

3.3.7 FOV (Field of View)

Main Menu > Imager > FOV

The field of view (FOV) is the area that the sensor can see at a given working distance. The working distance is the distance from the sensor's lens cover to the part being inspected. By default, the sensor uses the entire FOV in its operation. The effective FOV can be reduced in order to speed up the processing time of an inspection or to decrease background noise.



Maximize FOV

Main Menu > Imager > FOV > Maximize FOV

If the FOV has been modified and you want to quickly get back to the default, click the Maximize FOV menu option to restore the FOV to the entire sensor display.



Modify FOV

Main Menu > Imager > FOV > Modify FOV

Use this option to reduce or alter the size of the FOV.

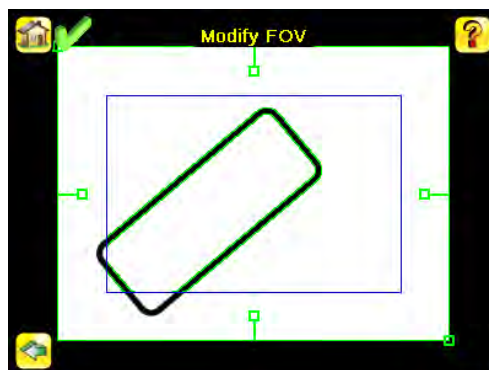

3.4 System Menu

Main Menu > System

The System menu icon is on the Main Menu, and is used to manage the sensor. The System menu provides for selecting Sensor Mode, updating sensor firmware, backing up and restoring sensor Configuration, and other general system-level operations.

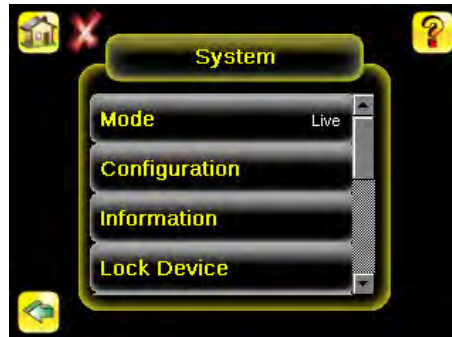

3.4.1 Mode

Main Menu > System > Mode

The sensor has two operating modes:

- Live Mode, which is the normal operating mode where the sensor captures live images, scans, and verifies barcodes
- Demo Mode, where inspections are run on stored images and inspection parameters.

The first time the device is powered up it starts in Demo Mode. Demo Mode uses stored images and inspection parameters that demonstrate how the sensor is set up without having to worry about focus, lighting, or triggers. In this mode, practice making adjustments while observing how the adjustments affect the results. To exit Demo Mode go to Main Menu > System > Mode and select Exit Demo Mode. Upon exit, the sensor reboots into its normal operating mode with default settings.



NOTE: Switch between Live Mode and Demo Mode any time by going to Main Menu > System > Mode.

3.4.2 System Configuration

Main Menu > System > Configuration

The Sensor Configuration menu options are:

- Save sensor Configuration to the USB flash drive
- Load sensor Configuration from the USB flash drive
- Reset the sensor Configuration to defaults

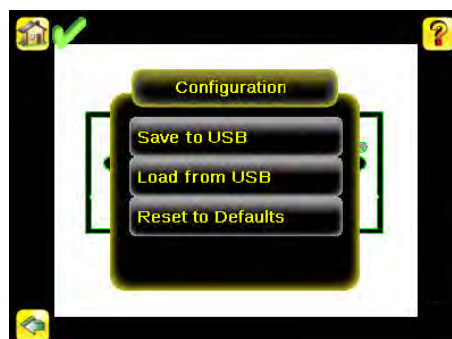

Save to USB

Main Menu > System > Configuration > Save to USB

The Save to USB screen allows the sensor Configuration to be saved to a USB flash drive. The saved configuration information can be used as a backup or as a way to clone configuration information for other sensors.



NOTE: On the Emulator, this option is Save Configuration.

Load from USB

Main Menu > System > Configuration > Load from USB

The Load from USB screen allows the sensor Configuration to be restored from a USB flash drive. This operation removes all existing inspections and replaces them with inspections contained in the configuration file on the USB flash drive.



NOTE: On the Emulator, this option is Load Configuration.

Reset to Defaults

Main Menu > System > Configuration > Reset to Defaults

Resets all sensor configurations to the factory defaults. This operation will remove all existing inspections and replace them with factory default settings.

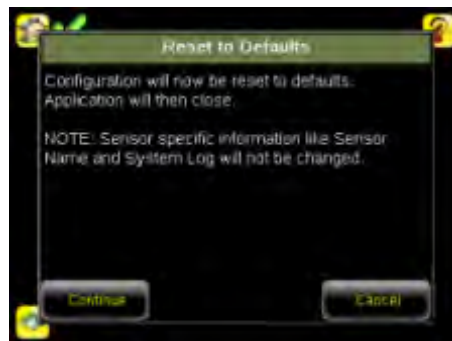

3.4.3 System Information

Main Menu > System > Information

The Information screen displays the following sensor information:

- Serial Number
- Firmware Version
- Boot Number
- Up Timer—the time elapsed since last boot of the sensor
- Hour Count—the total hours of operation in the sensor's lifetime
- Model Number
- Device Name

Click the right-arrow next to the Sensor Name field to display a software keyboard that allows you to change the Sensor Name. You may set the sensor name in English on the device. To set the sensor in any other language, please use the Emulator software.

3.4.4 Lock device

Main Menu > System > Lock device

This option provides for locking the sensor to prevent accidental modification of settings. When locked, the sensor only provides access to pass/fail statistics, as well as the ability to view logs and to save them to a USB device. A lock icon in the upper left corner of the sensor display indicates that the sensor is locked. Note that the sensor can be locked with or without a password. If a password is not used, unlock the sensor by clicking on the Unlock device menu. When a password

is used, it must be 4 digits entered using the software keypad. If the password is lost, use the Password Reset Utility software provided on the CD to obtain a Reset Key.



NOTE: This menu option is not available in the Emulator.

3.4.5 Communications

Main Menu > System > Communications

The Communications menu is used to configure the serial and ethernet I/O channel. There are six menu options:

- Ethernet I/O for configuring the Ethernet port
- Serial I/O for configuring the Serial port
- Industrial Ethernet settings
- Command Channel for sending commands to get specific data through Serial or Ethernet channels.
- Data Export Channel for enabling or disabling the channel for data export only
- Image Export Channel for enabling or disabling the channel for image export only



NOTE: Serial I/O can be configured either for Data Export or Command Channel. Image Export is only available on Ethernet.

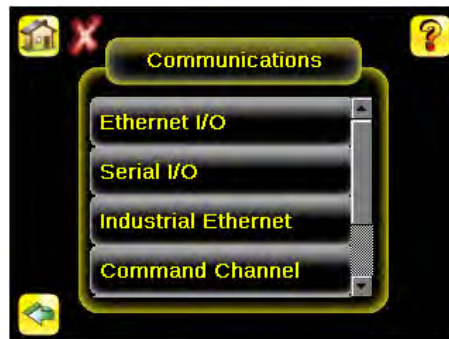

Ethernet I/O

Main Menu > System > Communications > Ethernet I/O

The sensor's Ethernet communications can be used to send data out the Ethernet port as part of an inspection, and remote devices can communicate with the sensor. The Ethernet I/O screen is where IP Address, Subnet Mask, and Gateway settings are configured. Use the expand arrow next to each field to display a software keypad to enter values for each field. Click Status at the bottom of the screen to verify communications as you connect to remote devices.

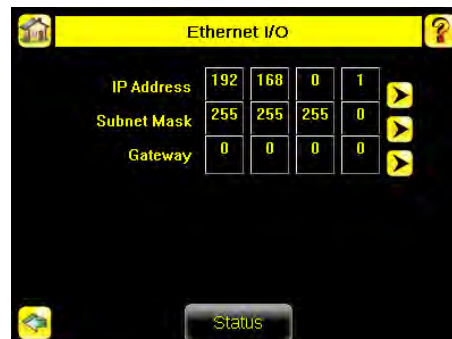

Ethernet I/O Status

Main Menu > System > Communications > Ethernet I/O > Status

The Ethernet I/O Status screen can be used to verify that the Ethernet wiring has been correctly set up. In addition to determining if the link has been established, incoming and outgoing traffic can be monitored.

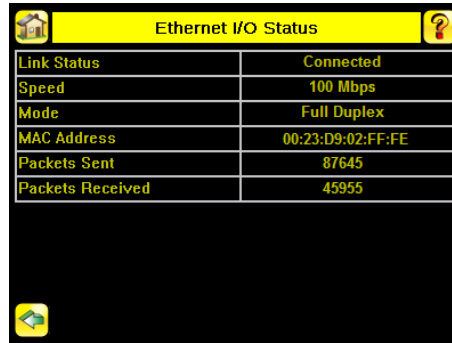

The screenshot shows the 'Ethernet I/O Status' screen with a yellow header bar. Below the header is a table with the following data:

Link Status	Connected
Speed	100 Mbps
Mode	Full Duplex
MAC Address	00:23:D9:02:FF:FE
Packets Sent	87645
Packets Received	45955

At the bottom left of the screen is a refresh icon, and at the bottom right is a question mark icon.

Serial I/O

Main Menu > System > Communications > Serial I/O

Set Serial I/O settings for Baud Rate, Data Bits, Parity Control and Stop Bits on this screen. Clicking Status displays recent bytes transmitted through this channel.



The screenshot shows the 'Serial I/O' settings screen with a yellow header bar. Below the header is a table with the following settings:

Baud Rate	115200
Data Bits	8
Parity Control	None
Stop Bits	1

At the bottom center of the screen is a 'Status' button, and at the bottom left is a refresh icon.

Port Status

Main Menu > System > Communications > Serial I/O > Status

The Port Status screen can be used to ensure data is entering and exiting the sensor. This can be useful for debugging issues such as improper wiring, mismatched baud rates, or other serial I/O issues.



The screenshot shows the 'Port Status' screen with a yellow header bar. Below the header, there are two text boxes showing the last bytes received and sent:

Last Bytes Received (22 Total):
do trigger\x0D\x0A do trigger

Last Bytes Sent (4 Total):
OK\x0D\x0A

At the bottom of the screen, it says 'Port Status: No Errors'. There are 'Clear' and 'HEX' buttons at the bottom center and right, respectively, and a refresh icon at the bottom left.

Industrial Ethernet

Main Menu > System > Communications > Industrial Ethernet

The iVuPlus device can be controlled or monitored over Industrial Ethernet using Ethernet/IP, Modbus/TCP or PCCC protocols. This document will help you to set up the iVu Plus in the desired configuration and provide you with information you will need to connect to the master device (PLC, HMI, etc.).

Connection

Main Menu > System > Communications > Industrial Ethernet > Connection

The Connection screen is used to enable either Modbus or EIP/PCCC protocols on Industrial Ethernet channel. Select 'Disable' to completely disable Industrial Ethernet channel.

Map

Main Menu > System > Communications > Industrial Ethernet > Map

The Map setting (Default/Custom) affects only on EIP assembly 0x65 or MODBUS/PCCC registers 30001 to 30240 at offset 55-166.

Default Map

Main Menu > System > Communications > Industrial EtherNet > Map > Default

Automatically maps sensor data for each inspection. Recommended when execution order of sensor types is the same across inspections. When inspection has multiple sensors, the first 5 sensor results will be shown starting at offset 55. Each sensor result will occupy 20 words.

The following is a table of EIP assembly 0x65 when using Default Map setting.

WORD #	WORD NAME	Data Type
0	Input Bits ACK Register	16-bit integer
1	Output Bits Register	16-bit integer
2-3	Error Code	32-bit integer
4-5	Inspection Number	32-bit integer
6-7	Iteration Count	32-bit integer
8-9	Pass Count	32-bit integer
10-11	Fail Count	32-bit integer
12-13	Missed Triggers	32-bit integer
14-15	Current Inspection Time	Float
16	Sensor Pass/Fail Coil	16-bit integer
17-29	reserved	
30-52	Inspection Name	2-Word Length + 20-Unicode chars
53-54	Frame Number	32-bit integer
55	Sensor Type ID (Sensor 1)	16-bit integer
56-74	Sensor 1 Specific Data	16-bit integer
75	Sensor Type ID (Sensor 2)	16-bit integer
76-89	Sensor 2 Specific Data	16-bit integer
95	Sensor Type ID (Sensor 3)	16-bit integer
95-114	Sensor 3 Specific Data	16-bit integer
115	Sensor Type ID (Sensor 4)	16-bit integer
116-134	Sensor 4 Specific Data	16-bit integer
135	Sensor Type ID (Sensor 5)	16-bit integer
136-154	Sensor 5 Specific Data	16-bit integer
155-170	reserved	
171	Command Status	16-bit integer
172	Command Response Int16	16-bit integer
173-174	Command Response Int32	32-bit integer

iVu Plus TG Image Sensor

WORD #	WORD NAME	Data Type
175-176	Command Response Float	Float
177-178	Command Response Length	32-bit integer
179-228	Command Response Data	100 Byte Array
229-239	reserved	

If the inspection contains more than 5 sensors, the sensor(s) after the 5th one will not be on the map.

Table 2: Area Sensor Type ID = 2

Sensor Specific Data	Data Size
Area Count	32- bit integer
Area Range Min	32- bit integer
Area Range Max	32- bit integer

Table 3: Blemish Sensor Type ID = 3

Sensor Specific Data	Sensor Location
Blemish Count	32- bit integer
Blemish Min Edge Length	32- bit integer
Blemish Min Edge Length	32- bit integer

Table 4: Match Sensor Type ID = 4

Sensor Specific Data	Sensor Location
Match Count	32- bit integer
Match Min Percent	16- bit integer
Match Max Percent	16- bit integer

Table 5: Sort Sensor Type ID = 5

Sensor Specific Data	Sensor Location
Sort Pattern Map	16-bit integer
Sort Pattern Count	16-bit integer
Sort Pattern 1 Count	16-bit integer
Sort Pattern 2 Count	16-bit integer
Sort Pattern 3 Count	16-bit integer
Sort Pattern 4 Count	16-bit integer
Sort Pattern 5 Count	16-bit integer
Sort Pattern 6 Count	16-bit integer
Sort Pattern 7 Count	16-bit integer
Sort Pattern 8 Count	16-bit integer
Sort Pattern 9 Count	16-bit integer
Sort Pattern 10 Count	16-bit integer
Sort Min Percent Match	16-bit integer
Sort Max Percent Match	16-bit integer

Custom Map

Main Menu > System > Communications > Industrial EtherNet > Map > Custom

Allows customization of fix sensor data on the map. Select data items of interest for each sensor type. Recommended when execution order of sensor types vary across inspections or when using more than 5 sensors.

A System level custom map is supported for additional flexibility. When Custom Map is selected, a customizable space is used in the offset range (55 to 166) on EIP assembly 0x65 registers.

The following is a table of EIP assembly 0x65 registers when using Custom Map setting.

WORD #	WORD NAME	Data Type
0	Input Bits ACK Register	16-bit integer
1	Output Bits Register	16-bit integer
2-3	Error Code	32-bit integer
4-5	Inspection Number	32-bit integer
6-7	Iteration Count	32-bit integer
8-9	Pass Count	32-bit integer
10-11	Fail Count	32-bit integer
12-13	Missed Triggers	32-bit integer

WORD #	WORD NAME	Data Type
14-15	Current Inspection Time	Float
16	Sensor Pass/Fail Coil	16-bit integer
17-29	<i>reserved</i>	
30-52	Inspection Name	2-Word Length + 20-unicode chars
53-54	Frame Number	32-bit integer
55-166	Customizable Space (112 reg)	
167-170	<i>reserved</i>	
171	Command Status	16-bit integer
172	Command Response Int16	16-bit integer
173-174	Command Response Int32	32-bit integer
175-176	Command Response Float	Float
177-178	Command Response Length	32-bit integer
179-228	Command Response Data	100 Byte Array
229-239	<i>reserved</i>	

Custom Map Export

Main Menu > System > Communications > Industrial Ethernet > Map > Custom > (Save icon)



To export the Custom Map, Click  to save a text listing of the map (Filename: iVuIEMap.csv) to an attached USB drive. (This operation is also supported on Emulator; iVuIEMap.csv will be saved on the application folder.)

Status

Main Menu > System > Communications > Industrial Ethernet > Status

The status screen displays information about the current connection. This information is protocol specific.

View Logs

Main Menu > System > Communications > Industrial Ethernet > View Logs

This screen displays the list of recent events on Industrial Ethernet channel. Detailed logging can be selected under Setup when troubleshooting.

Command Channel

Main Menu > System > Communications > Command Channel

The iVu command channel is a bi-directional communication protocol that currently supports ASCII via the RS-232 serial interface or ethernet interface, and enables other devices to remotely control the iVu sensor and to access sensor results.

Connection

Main Menu > System > Communications > Command Channel > Connection

The Connection screen is used to enable or disable the Command Channel.

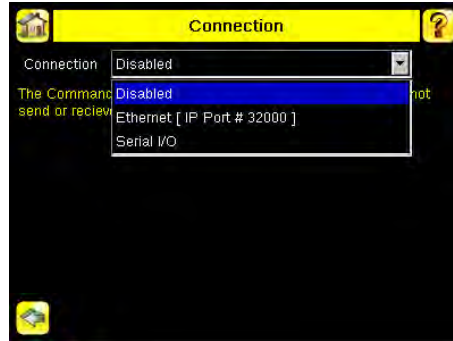
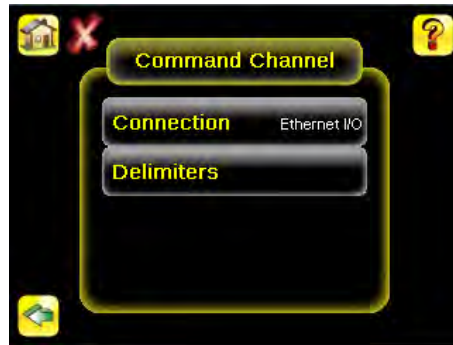

Delimiters

Main Menu > System > Communications > Command Channel > Delimiters

In the Delimiters screen, there are three delimiter options that you can set:

- Field Delimiter, which determines what is used to separate data that the sensor is sending out to a remote device.
- End of Frame, which determines the delimiter used to indicate the end of a frame.
- String Delimiter, which determines what is used to enclose a string field during both input and output operations.

Use the drop-down lists to select the appropriate delimiter. The example at the lower part of the screen displays how the data will look in the output or input streams.

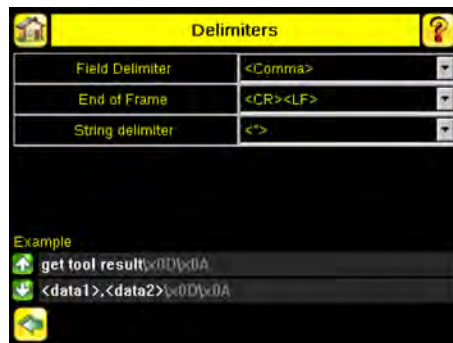

Data Export

Main Menu > System > Communications > Data Export

When the Data Export is enabled, the sensor will transmit selected inspection data when triggered.

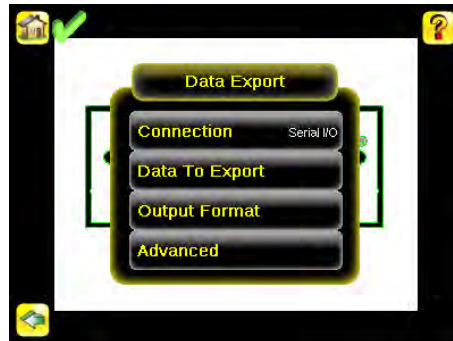

Connection

Main Menu > System > Communications > Data Export > Connection

The Connection screen is used to enable or disable the Data Export Channel.

Data To Export

Main Menu > System > Communications > Data Export > Data To Export

The Data To Export screen is used to determine the information included in a data export. Data will output in the order displayed on the screen.



NOTE: Grab the edge of the Data to Export menu and pull down to allow all information to show.

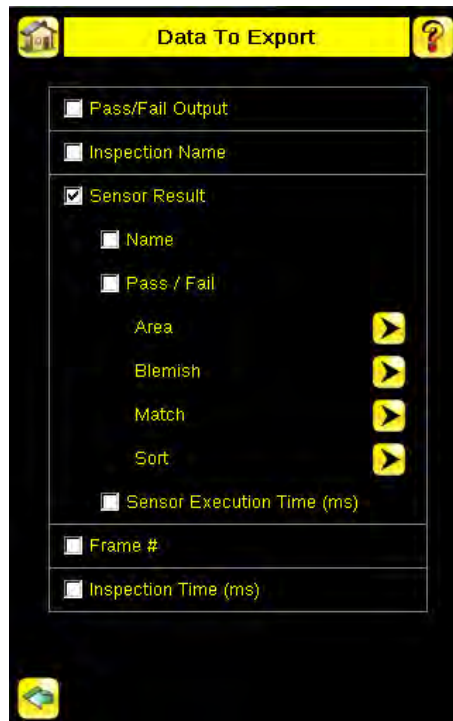

Output Format

Main Menu > System > Communications > Data Export > Output Format

In the Output Format screen, use the drop-down lists to select Start and End Strings as well as a Delimiter. In the field at the bottom of the screen is an example of how the data will look when it is output.

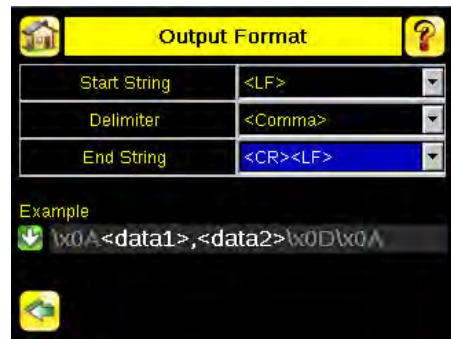

Data Export Advanced

Main Menu > System > Communications > Data Export > Advanced

During the Data and Image export operation, the sensor's output channels might become full. This can occur if the sensor is producing export data (frames) faster than the data can be exported from the device or faster than the client is reading the channel export data (due to bandwidth limitations).

This setting affects how the sensor will behave in this situation.

Select 'Hold READY' to ensure that all frames are transmitted. In this case, the READY signal will remain inactive (sensor is busy) until the new frame has been added to the channel for transmission. Triggers might be missed during this time.

Select 'Do not hold READY' to cause the sensor to discard the new frame if the channel is full and thus activate the READY signal immediately after the current inspection is complete. In this case, the discarded frames will not be transmitted.



NOTE: This setting affects both the Data Export Channel and Image Export Channel.

Image Export

Main Menu > System > Communications > Image Export

When the Image Export Channel is enabled, the sensor will transmit the acquired image on every trigger. The image is transmitted as a bitmap (BMP) file. This operation is only available over Ethernet I/O.

Connection

Main Menu > Communications > Image Export > Connection

The Connection screen is used to enable or disable the Image Export.

Image Type

Main Menu > System > Image Export > Image Type

Choose between JPEG or BMP format for the exporting image file.

Image Export Advanced

Main Menu > System > Communications > Image Export > Advanced

During the Data and Image Export operation, the sensor's output channels might become full. This can occur if the sensor is producing export data (frames) faster than the data can be exported from the device or faster than the client is reading the channel export data (due to bandwidth limitations).

This setting affects how the sensor will behave in this situation.

Select 'Hold READY' to ensure that all frames are transmitted. In this case, the READY signal will remain inactive (sensor is busy) until the new frame has been added to the channel for transmission. Triggers might be missed during this time.

Select 'Do not hold READY' to cause the sensor to discard the new frame if the channel is full and thus activate the READY signal immediately after the current inspection is complete. In this case, the discarded frames will not be transmitted.



NOTE: This setting affects both the Data Export Channel and Image Export Channel.

3.4.6 Discrete I/O

Main Menu > System > Discrete I/O

The Discrete I/O options are used to adjust iVu input and output settings.

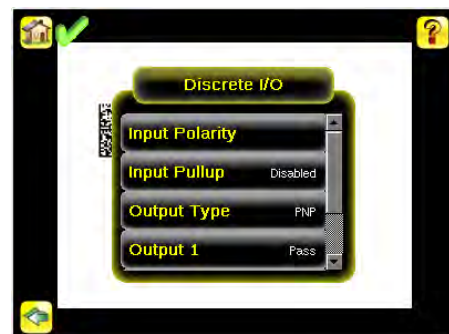

Input Polarity

Main Menu > System > Discrete I/O > Input Polarity

The iVu has two input signals—Trigger and Remote Teach. Both of these signals are edge sensitive. The operation of these signals is dependent on the Input Polarity setting.

- Low To High - The Trigger and Remote Teach are detected on a low to high transition of the signal.
- High To Low - The Trigger and Remote Teach are detected on a high to low transition of the signal.

The default setting for a PNP sensor is Low To High, and for an NPN sensor it is High To Low. The user can change the setting on the Input Polarity screen.

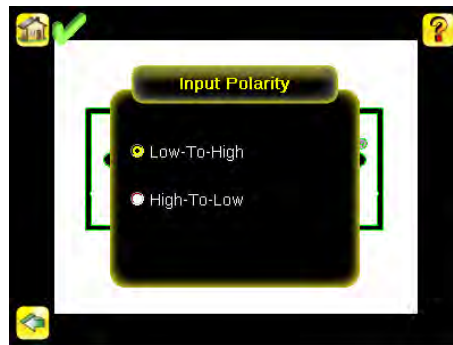

Input Pullup

Main Menu > System > Discrete I/O > Input Pullup

By default, the Input Pullup is disabled. If the device used to trigger and remote teach the iVu sensor is a Sinking device (NPN) then you will only need to enable Input Pullup here if that device does not have its own pullup resistor. Otherwise, this should be disabled.

Output Type

Main Menu > System > Discrete I/O > Output Type

Select NPN to configure the sensor's outputs to sink current. Select PNP to configure the sensor's output for source current.

Output 1, 2, and 3

Main Menu > System > Discrete I/O > Output (#)

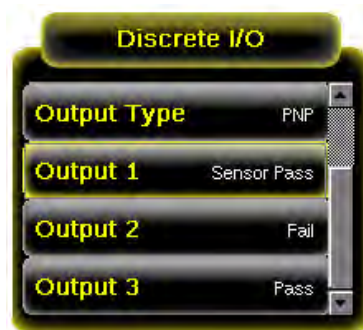

Output 1, 2, and 3 are setup separately to improve flexibility and simplicity.

Output can be configured for Inspection Pass, Inspection Fail, Sensor Pass, Sensor Fail, Sort Pattern #1, Missed Trigger or System Error.

- A Missed Trigger condition occurs when a trigger is received while sensor is busy inspecting the previous image. This output signal will be set to active state. This signal will be reset up on resetting the 'History' on the statistics page.
- A System Error condition occurs when a fatal error is detected on the sensor. This output signal will be set to active state. This signal can be reset upon resetting the History on the statistics page, or executing a 'ClearSystemError' command through command channel.

The default setting is Pass and Latched for Output 1. If Pulsed is selected, the default Pulse width is 50 ms.



NOTE: For Latched the signal is active until the results of an inspection cause a change in the signal output.

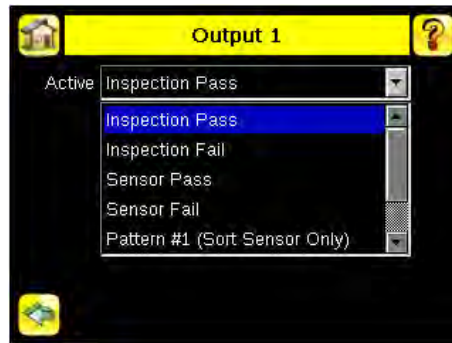

When either Sensor Pass or Sensor Fail is selected, additional setting will become available as shown on the following graphic.

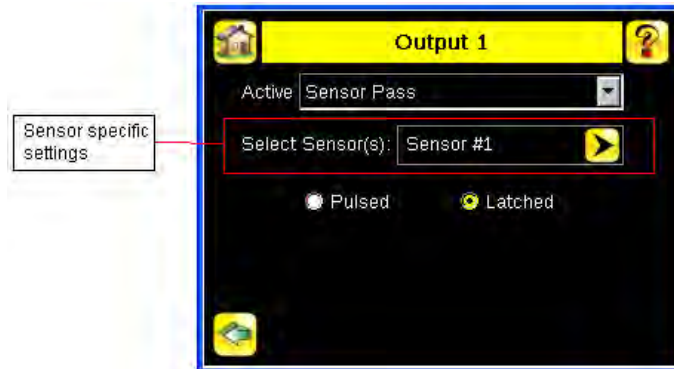

Click on the yellow arrow button to access the Select Sensor screen.

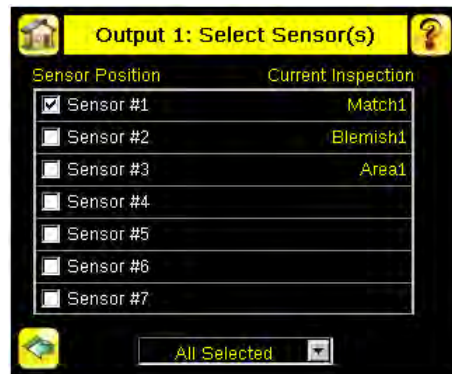

On the Select Sensor screen, the left column check box allows adding sensor position to be part of the logic that activates the output. One or more sensor positions can be added. The right column on the table shows the sensor name(s) and their respective position from the current inspection for reference.

The bottom drop list has two settings:

- All Selected: All checked sensor positions must meet the setting criteria (Pass/Fail) to activate the output.
- Any Selected: Any checked sensor position that meets the setting criteria (Pass/Fail) will activate the output.

When a selected sensor position is missing on the current inspection, the missing sensor(s) will not be part of the logic to activate the output. For example: when only 2 sensors are included on the current inspection and the Output > Select Sensor(s) has Sensor #1, Sensor #2 and Sensor #3 checked; only Sensor #1 and Sensor #2 will be used to determine the output state, as Sensor #3 is not defined by the current inspection.

3.4.7 Display Settings

Main Menu > System > Display Settings

The Display Settings menu is for setting the Fail Hold Time, LCD Timeout, and doing a Touch Screen Calibration. Display optimization can be enabled in the Advanced menu.

Fail Hold Time

Main Menu > System > Display Settings > Fail Hold Time

The Fail Hold Time determines how long a failed image is displayed on the LCD so that you can see what failed. The sensor will continue to process any triggers and the inspection will continue normally. This time delay is just for the screen. You can set this parameter from 0 to 3600 seconds using the slider at the bottom of the screen.



LCD Timeout

Main Menu > System > Display Settings > LCD Timeout

The LCD screen dims after a user-selectable period when the device is not being used. Use the arrow keys or slide the bar at the bottom of the screen to set the LCD screen time out.



NOTE: This screen is not available in the Emulator.

Touch Calibration

Main Menu > System > Display Settings > Touch Calibration

Touchscreen Calibration may be necessary if the software does not correctly respond when an icon on the screen is pressed. The calibration routine aligns the touch screen's coordinates to the display behind it. Be sure to follow the prompts on the screen when executing the Touchscreen Calibration function.



NOTE: This screen is not available in the Emulator.

Advanced

Main Menu > System > Display Settings > Advanced

The Advanced Display screen allows you to enable the Optimize Display Response option. This feature helps to make the display more responsive when the sensor is busy (either inspection times are long and/or no idle time exists between inspections). Disable this feature if Missed Triggers occur due to touchscreen presses. With this setting disabled, the display may become sluggish when the sensor is busy.

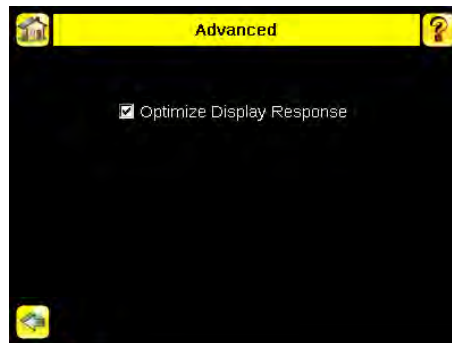

3.4.8 Reboot Sensor

Main Menu > System > Reboot Sensor

The Reboot Sensor screen allows you to force a reboot of the sensor.



NOTE: This option is not available on the Emulator.

3.4.9 Firmware Update

Main Menu > System > Firmware Update

The Firmware Update screen is used to load the latest sensor firmware. The Firmware Update screen lists the firmware versions it finds in the BANNER\FIRMWARE folder on the USB flash drive. When you receive a firmware update from Banner Engineering, be sure to put it in the BANNER\FIRMWARE folder on the USB flash drive.



NOTE: The Firmware Update menu is not available in the Emulator.

3.5 Logs Menu

Main Menu > Logs

The Logs menu icon is on the Main Menu, and is used to set up, view, and save Inspection, Communication, and System Logs.

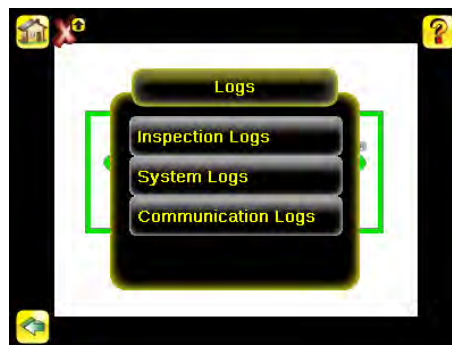

3.5.1 Inspection Logs

Main Menu > Logs > Inspection Logs

This menu provides for configuring and viewing Inspection Logs. Inspection Logs are stored inspection records that include a captured image, the parameters used to inspect it, and the results of that inspection. Up to ten Inspection Logs can be held in memory on the sensor. The next ten overwrite the previous. Inspection Logs can be saved to the USB flash drive so that the logs can be imported to the emulator.

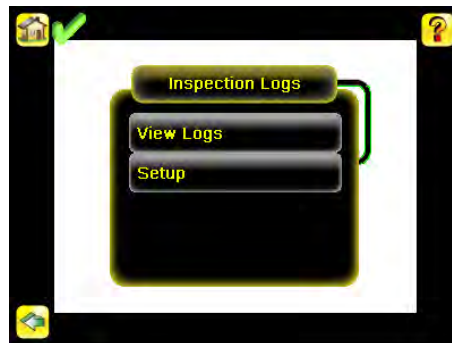

View Logs

Main Menu > Logs > Inspection Logs > View Logs

Inspection Logs appear as a strip of film. You can select a frame to view a specific image. Use the icon in the lower right of the screen to save the logs to the USB flash drive. Logs saved to the USB flash drive can be imported into the emulator. Click the Clear button to clear Inspection Logs.

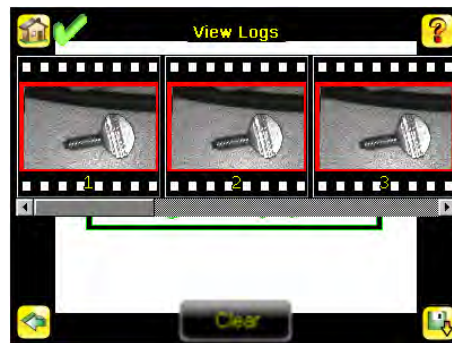

The View Inspection Log screen is used to debug an inspection, and shows one inspection in read-only mode. Click the upper-left icon to cycle through views. When in Statistics view, the table title has arrows to switch between Inputs and Results of the Inspection.

Use the left and right arrow keys at the bottom of the screen to navigate through the all stored Inspection Logs.

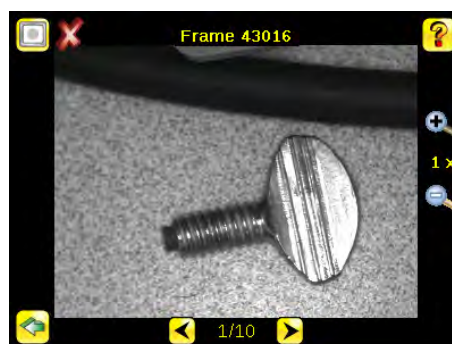

Setup

Main Menu > Logs > Inspection Logs > Setup

Use the radio buttons to Disable Logging, to log Passed Inspections, Failed Inspections, or All Inspections.

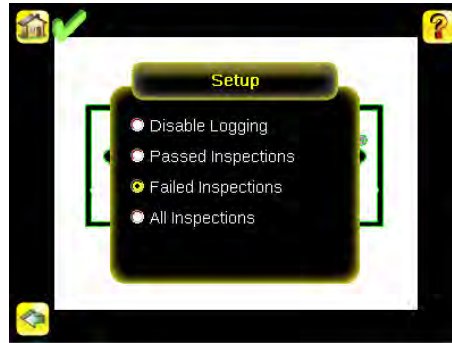

3.5.2 System Logs

Main Menu > Logs > System Logs

The System Log contains configuration change information, other notifications, and any errors or warnings that may be encountered. The list is sorted in descending order with respect to time. The 'Time' associated with each event consists of the Hour Count (lifetime hours of operation) and the Up Timer (time elapsed since last boot).

- Click the icon in the upper left corner of the screen to show/hide the time column
- Click Clear Log button at the bottom of the screen to clear the System Log
- Click the icon at the lower-right of the screen to save the System Log to the USB flash drive



NOTE: System log will not log changes while in Demo mode. Additionally, the Emulator does not log changes.

3.5.3 Communication Logs

Main Menu > Logs > Communication Logs

The Communication Log contains logs for the four communications channels; Industrial Ethernet, Command Channel, Data Export, and Image Export. The features below are available for each of the logs:

- Click the icon in the upper left corner of the screen to show/hide the time column.
- Click Clear Log button at the bottom of the screen to clear the log.
- Click the icon at the lower-right of the screen to save the Log to the USB flash drive.



NOTE: Communication log will not log changes while in Demo mode. Additionally, the Emulator does not log changes.

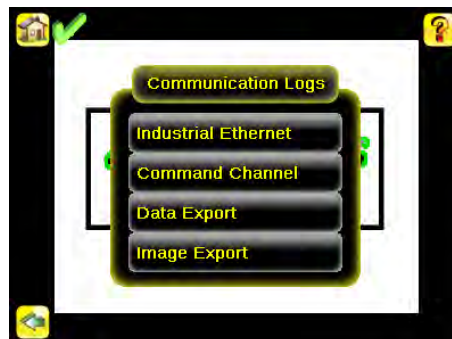

Industrial Ethernet Log

Main Menu > Logs > Communication Logs > Industrial Ethernet Log

The Industrial Ethernet Log logs the most recent Industrial Ethernet activity.

Command Channel Log

Main Menu > Logs > Communication Logs > Command Channel

The Communication Log logs the most recent Command communication activity. Each entry in the log includes a status indicator for the operation. A green indicator displays when the channel is enabled or disabled—light green when the channel is enabled and dark green when the port is disabled.

An up-arrow displays for incoming requests from a remote device. A down-arrow displays for outgoing responses from the iVu sensor. The up- and down-arrows are green when everything is OK and red if there is an error. The up-arrow will be yellow if the command is incomplete (for example, waiting for an end-of-frame delimiter).



NOTE: An hourglass displays if an operation takes a particularly long time to complete; for example, during a long trigger.

Each log entry includes a log detail button (arrow icon on right side of log entry) to display a detail view of the log entry. Buttons at the bottom of the screen provide for refreshing the display and clearing the log. Additionally, the communication log can be saved to the USB flash drive so that the communication log can be imported to the emulator.

Command Channel Logs	
Time 198-0:11:3 Total Errors: 3	
Time	Description
198-0:0:10	Channel Enabled On Ethernet Port 3
198-0:8:33	Connection established to client 192
198-0:8:53	Get History Passed\x0D\x0A
198-0:8:53	OK\x0D\x0A
198-0:8:53	2087\x0D\x0A
198-0:8:56	Get History Failed\x0D\x0A
198-0:8:56	OK\x0D\x0A
198-0:8:56	0\x0D\x0A

Image Export Log

Main Menu > Logs > Communication Logs > Image Export

The Image Export log is purely an output log so there is no receive (input) activity. Image Export is only available over Ethernet. When a user enables Image Export, the log will show an Enabled entry that indicates the port is being listened to. When a client application connects or disconnects, a log entry indicates that which IP address has connected or disconnected. If data is dropped, the logs will indicate the number of frames that have been dropped.

4 Setting up an Inspection

The device holds up to 30 inspections. Inspections may hold multiple sensors.

To set up for an inspection:

1. Acquire a good image.
2. Configure the sensor(s) in the inspection
3. Configure multiple sensors in the inspection

4.1 Acquiring a Good Image

The iVu Series sensor needs to capture a good image of each part to ensure that it correctly passes good parts and fails bad parts.

1. Go to Main Menu > Imager > Auto Exposure to run the Auto Exposure routine.
2. Check the lighting.
 - Make sure that the lighting is constant and consistent (unchanging over time, no shadows or hot spots).
 - Capture the shape and form of the target object with lighting that optimizes its contrast and separates it from the background. Depending on the target, this may mean the integral ring light is not the best choice and other Banner lights should be considered.
 - Adjust the mounting angle to provide the clearest image of the part features you are monitoring. The mounting bracket lets you easily position and adjust the sensor on your line.
3. If needed, go to Main Menu > Imager > Auto Exposure to run the Auto Exposure routine a second time or adjust Gain and Exposure manually:
 - Main Menu > Imager > Gain



- Main Menu > Imager > Exposure



4. Go to Main Menu > Imager > Focus to adjust the focus while monitoring the Focus Number:



For Micro Video Lens Models Only:

1. Use the supplied 1/16 in. hex key to loosen the Focusing Window locking screw (D), then adjust focus on the iVu Series sensor using the clear Focusing Window (B).
2. Adjust focus while monitoring the focus number. To ensure the best image, adjust the focus until the Focus Number peaks.



NOTE: Turning the Focusing Window counter-clockwise focuses on closer objects, while turning the Focusing Window clockwise focuses on more distant objects.



3. After the best image has been acquired, lock the focusing window.

Micro Video Lens Models	
	A Lens
	B Focusing Window
	C Locking Clip
	D Locking Screw
	E Filter Cap (optional)
	F Filter (optional)
	NOTE: Filter Kits are available separately.

For C-Mount Models Only:

1. Remove the Lens Enclosure.
2. Adjust focus while monitoring the focus number. To ensure the best image, adjust the focus until the Focus Number peaks.
3. Replace the Lens Enclosure on the camera.

C-Mount Models	
	A C-Mount Lens
	B Lens Enclosure
	C Retainer Ring (optional)
	D Filter (optional)
	E Filter Retainer Ring Tool
	NOTE: Filter Kits are available separately.

5 Configuring Sensors

Each sensor type has a shortcut menu available from the inspection menu.

From the Home screen, click inside the Region of Interest (ROI). The ROI is the visual area indicated by a dotted line on the inspection. In the Demo mode this will be the Banner logo. The dotted line will turn bold and have rotation and size icons in the corners. At the top of the screen the Inspection Name will change to a black button called Sensor Name. Click the black Sensor Name button and a drop down box will appear.





No matter what parameter you are setting, if you click inside the ROI it will highlight into a bold dotted line that can be resized.

5.1 Sensor Configuration Shortcut Menu

Each sensor type has a shortcut menu available from the inspection menu.

From the Home screen, click inside the Region of Interest (ROI). The ROI is the visual area indicated by a dotted line on the inspection. In the Demo mode this will be the Banner logo. The dotted line will turn bold and have rotation and size icons in the corners. At the top of the screen the Inspection Name will change to a black button called Sensor Name. Click the black Sensor Name button and a drop down box will appear.

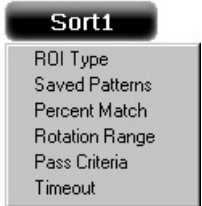
No matter what parameter you are setting, if you click inside the ROI it will highlight into a bold dotted line that can be resized.

Area Sensor	Blemish Sensor	Match Sensor	Sort Application
			
<p>The ROI type is the shape of the area of inspection. The ROI can be a rectangle, circle, or ellipse</p> 			
<p>Intensity Range is the range of gray scale values the sensor should look for. To set the Intensity Range, use the eye dropper on the left of the screen to select the target feature, then use the slider bar at the bottom of the display to fine tune the selection. As the slider bar is moved, green highlighted areas indicate objects the sensor finds.</p>	<p>The Sensitivity slider is used to fine-tune how much or how little contrast the sensor will recognize within the ROI. The Sensitivity value helps account for light variations that might affect how well the sensor detects edges. The Sensitivity scale is from 0 to 100 where 0 means least sensitive and 100 means most sensitive. If set near 0, the sensor will only find very sharp edges with strong contrast. If set near 100, the sensor will find very dim or blurry edges, and may be unstable.</p>	<p>-----</p>	<p>Saved Patterns is where to manage saved patterns including rename, or delete.</p>
<p>-----</p>	<p>-----</p>	<p>The Percent Match slider adjusts for how closely the inspected part or label matches the reference part or label. The Percent Match scale is from 0 to 100 where 0 is the most tolerant and 100 is the least tolerant. Percent Match and Rotation Range work together. For the best results, use a value from 50 to 90</p>	

Area Sensor	Blemish Sensor	Match Sensor	Sort Application
<p>The Area Range is used to set the size limits of a feature of interest. Use the slider bar at the bottom of the display to select the range. Areas are measured by counting pixels. For example, a rectangular feature that is 100 pixels wide by 200 pixels tall will have an area of roughly 20,000 pixels.</p>	<p>The Edge Length Range slider adjusts the edge pixels in the ROI. The slider of the Edge Length Range screen shows all the different contiguous edge segments found. Edge segments within the two brackets [] are highlighted in green and those outside the brackets are ignored and colored yellow. You can move each bracket to add or remove more of the edge segments from consideration.</p>	<p>The Rotation Range sets the expected rotation of parts or labels during an inspection. For example, a value of 45 means that the part may rotate 45 degrees in either direction from the reference part and still pass. Move the slider from 0 to 180 degrees. Note that the smaller the rotation range, the faster the inspection will run.</p>	
<p>The Pass Count establishes the pass/fail result of the inspection. The Minimum Pass Count is the minimum number of parts, labels, or features expected to fall within the specified criteria; the Maximum Pass Count is the maximum number expected to fall within the specified criteria. However with Blemish Pass Count - the count is about pixels. The specified criteria is the pixel range that falls in between the minimum and maximum pass counts.</p>			<p>Pass Criteria (assuming only two stored patterns):</p> <p>Any Saved Pattern—Pass condition if the sensor matches either Pattern_1, Pattern_2, or both</p> <p>All Saved Patterns—Pass condition if the sensor matches both Pattern_1 AND Pattern_2</p> <p>Single Saved Pattern—Pass condition if the sensor matches either Pattern_1 OR Pattern_2, but NOT both</p> <p>Specific Save Pattern (Must also select the saved pattern to match, for example, select Pattern_2)—Pass condition any time the sensor matches Pattern_2</p>
<p>-----</p>	<p>-----</p>	<p>Time Out is the amount of time the inspection will hit on an image. If it times out before the inspection is complete, it will fail.</p>	

5.2 Configuring an Area Sensor



NOTE: By default, the Trigger is set to Internal, and will continuously trigger based on a time interval setting. This may make it more difficult to make adjustments while setting up the sensor. The best practice is as follows:

- Go to the Main Menu > Imager > Trigger menu and select External.

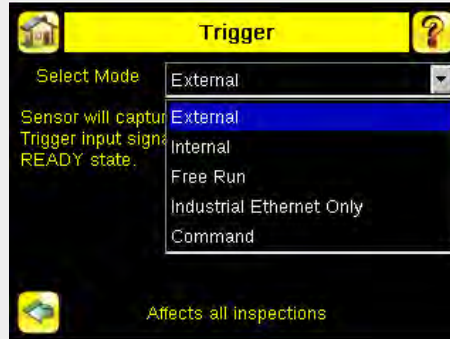

- Make sure there is no external trigger input.
- Use the Trigger icon in the lower-right of the screen to manually trigger the sensor to capture an image as you set up and test.
- Capture images of a range of samples to set up from the "worst" good part to the "best" bad part.

Start the setup with a good part. Normally, each part to be tested will be centered in the Field of View (FOV).

To adjust the Region of Interest (ROI), follow the steps listed here. The ROI is the red box as shown.

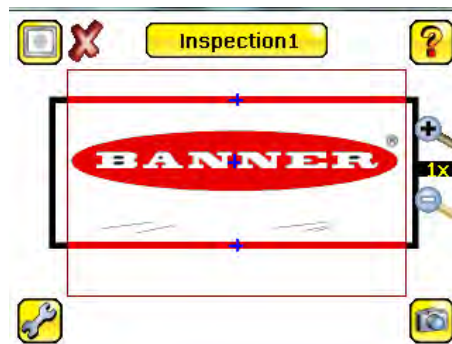

1. Click anywhere within the ROI to select it. When selected, the ROI has resize and rotational icons in the corners. It also changes the top button to the sensor name of the selected ROI.



2. Resize and move the ROI to surround the feature of interest. In the Demo example, the feature of interest is the Banner logo as shown here. It is still red because the parameters need to be set.



NOTE: When running an Area inspection, the sensor finds objects only within the ROI.

3. Click the black sensor name button to go to open the Area sensor parameters menu.



4. Set sensor parameters.
 - Adjust the Intensity Range. This is the range of grayscale values the sensor should look for. Use the eye dropper on the left of the screen to select the target feature, then use the slider bar at the bottom of the screen to fine tune the selection to set the intensity range.



- Adjust the Area Range. The Area Range is used to set the size limits of a feature of interest. Use the slider bar at the bottom of the display to select the range. As the range narrows, the highlighted area turns yellow. Areas are measured by counting pixels. For example, a rectangular feature that is 100 pixels wide by 200 pixels tall has an area of roughly 20,000 pixels. The screenshot indicates that the areas that are white are now within range of the inspection.



- Move the slider at the bottom of the screen to the desired area range. In the Demo example, the Area Range is adjusted so that each letter is identified as a found object (Indicated by the green highlight and the blue +).
- Set the Pass Count parameter. The Minimum Pass Count is the minimum number of parts, labels, or features expected to fall within the specified criteria; the Maximum Pass Count is the maximum number expected to fall within the specified criteria. These settings are used to determine the pass or fail result of the inspection.

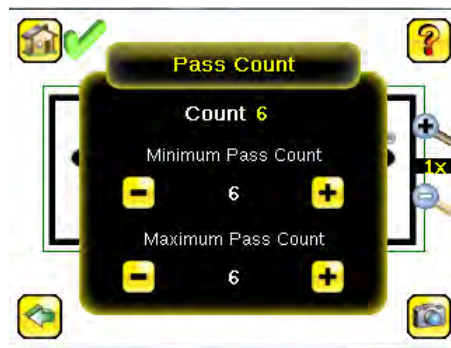

- Set the Minimum Pass Count and Maximum Pass Count as appropriate. In the Demo, both are set to 6, since the inspection should find six letters.
5. Test the complete range of good and bad samples to make sure that the sensor accepts good parts and rejects bad. The green check in the upper left corner indicates the inspection passed. The ROI turns green when the sensor passed and turns red when the sensor fails.
 6. To complete the Area application setup, set triggering as appropriate for the application.



NOTE: Remote Teach does not work with the Area Sensor type.

5.3 Configuring a Blemish Sensor



NOTE: By default, the Trigger is set to Internal, and will continuously trigger based on a time interval setting. This may make it more difficult to make adjustments while setting up the sensor. The best practice is as follows:

- Go to the Main Menu > Imager > Trigger menu and select External.

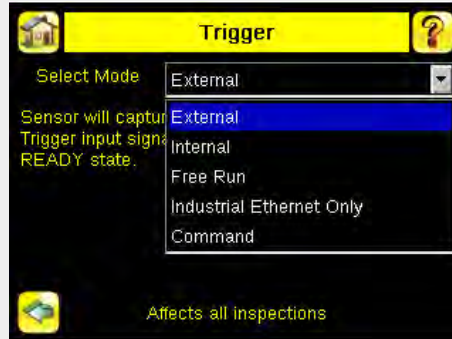

- Make sure there is no external trigger input.
- Use the Trigger icon in the lower-right of the screen to manually trigger the sensor to capture an image as you set up and test.
- Capture images of a range of samples to set up from the "worst" good part to the "best" bad part.

The Demo application shows how the sensor, when configured as a Blemish sensor, can accept or reject parts based on the range of edge pixels the sensor detects in the ROI.

Start the setup with a good part. Normally, each part to be tested will be centered in the Field of View (FOV).

1. Adjust the Region of Interest (ROI). Resize the ROI so that it surrounds just the feature of interest. In the Blemish Demo example, the feature of interest includes the two irregular shapes below the Banner logo.

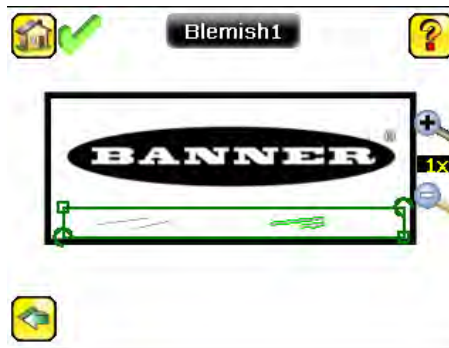

2. Adjust the parameters of the sensor by clicking inside the ROI then click the black sensor name button.

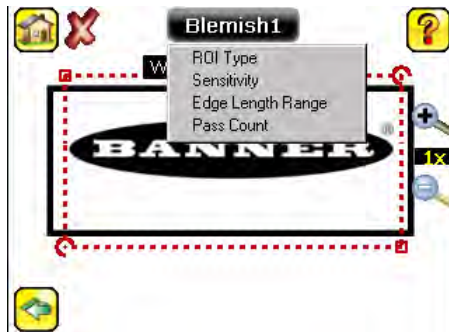

- Adjust the Sensitivity parameter. Sensitivity is used to fine-tune how sensitive the sensor is to finding blemish or other edges within the ROI. The Sensitivity value helps account for light variations that might affect how well the sensor detects edges. The Sensitivity scale is from 0 to 100, where 0 means least sensitive and 100 means most sensitive. If set near 0, the sensor will only find very sharp edges with strong contrast. If set near 100, the sensor will find very dim or blurry edges, and may be unstable.



- Use the slider on the bottom of the screen to adjust the sensitivity watching as the sensor detects more or fewer edges.
- Adjust the Edge Length Range. The sensor counts all the edge pixels it detects in the ROI. The bar at the bottom of the Edge Length Range screen shows all the different contiguous edge segments found. Edge segments within the two brackets [] are highlighted in green and those outside the brackets are ignored and colored yellow as in the example. You can move each bracket to add or remove more of the edge segments from consideration.

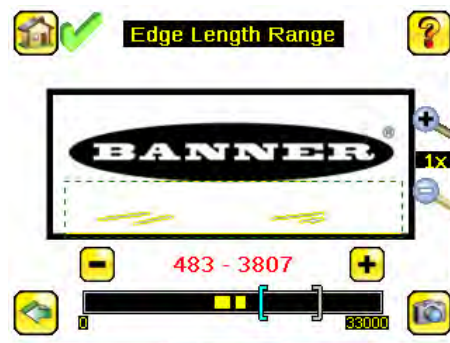

- Move the slider at the bottom of the screen to the desired Edge Length Range. You can zoom in to refine the range.

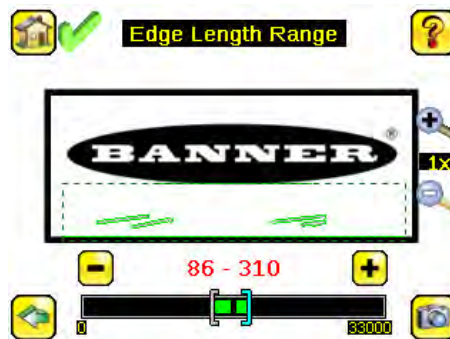

- Adjust the Pass Count parameter. The sensor aggregates all the edge pixels that fall within the Edge Length Range and indicates the value with a small colored bar at the bottom of the page. If within the range brackets, the bar is green, otherwise it is yellow.



- Use the brackets to set a tolerance for the pass/fail.



Now the inspection for the blemish sensor is set up to be sensitive enough to find blemishes under the logo and fail the inspection.

3. Test the complete range of good and bad samples to make sure that the sensor accepts good parts and rejects bad parts.
4. To complete the Blemish application setup, set triggering as appropriate for the application.



NOTE: Remote Teach does not work with the Blemish Sensor type.

5.4 Configuring a Match Sensor



NOTE: By default, the Trigger is set to Internal, and will continuously trigger based on a time interval setting. This may make it more difficult to make adjustments while setting up the sensor. The best practice is as follows:

- Go to the Main Menu > Imager > Trigger menu and select External.

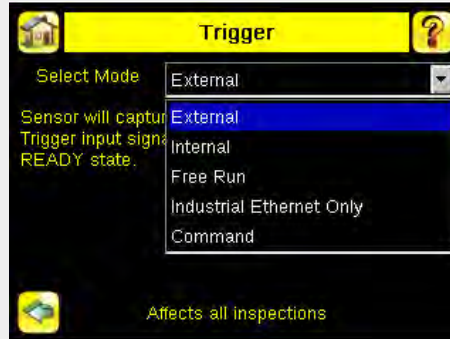

- Make sure there is no external trigger input.
- Use the Trigger icon in the lower-right of the screen to manually trigger the sensor to capture an image as you set up and test.
- Capture images of a range of samples to set up from the "worst" good part to the "best" bad part.

Start the setup with a good part. Normally, each part to be tested will be centered in the Field of View (FOV).

Teach the sensor a good reference part.

1. Adjust the Region of Interest (ROI). The ROI is a dotted box as shown.

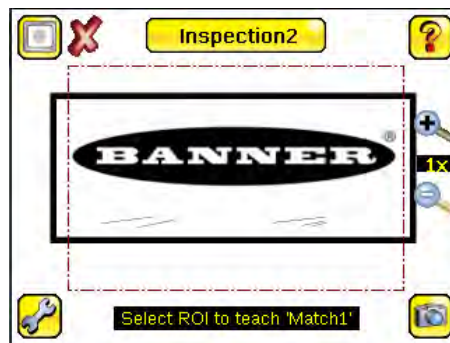

2. Click Anywhere within the ROI to select it. When selected, the ROI is bolded with resize and rotational icons in the corners.

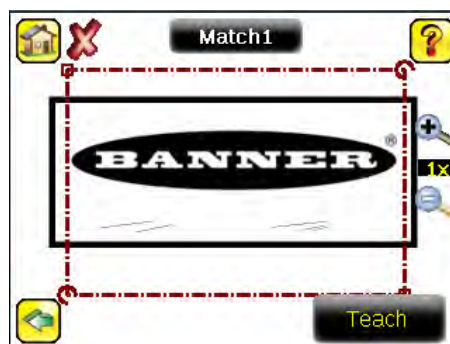

3. Resize the ROI so that it surrounds just the feature of interest. In the Demo example, the feature of interest is the Banner logo.



4. Click the Teach icon to teach the sensor this good reference part.



5. Set sensor parameters.

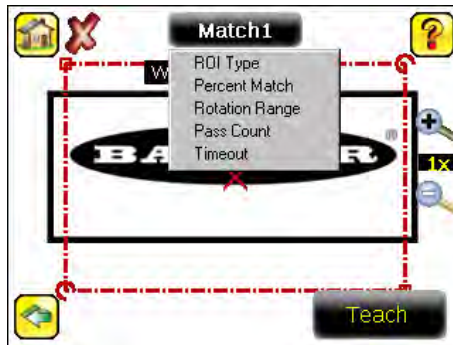

- Adjust the Percent Match parameter. The Percent Match setting adjusts for how closely the inspected part or label matches the reference part or label. The Percent Match scale is from 0 to 100 where 0 is the most tolerant and 100 is the least tolerant.

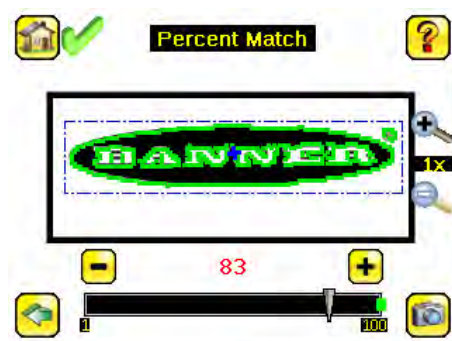



NOTE: When running a Match inspection with annotations enabled, the sensor will highlight in green any pattern matches that meet or exceed the value specified for Percent Match. Patterns that are below the specified value for Percent Match (down to approximately 20%), or out of the Rotation Range (see below), will be colored yellow.

- Using a "bad" part, click the Manual Trigger icon in the lower-right of the screen to capture an image. For this example, one of the stored images is missing the letter "N," yet the sensor initially sees this as a "good" label.

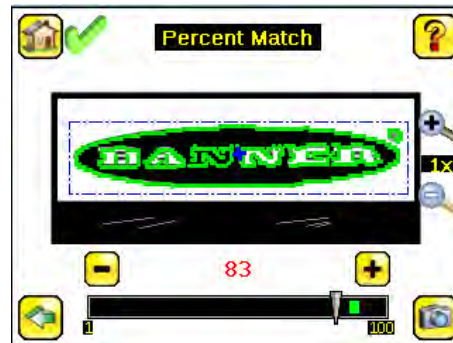

- On the adjustment at the bottom of the screen, adjust the slider and click the Manual Trigger button. When adjusted correctly, the annotations should turn yellow, and the icon in the upper-right of the screen should indicate fail.

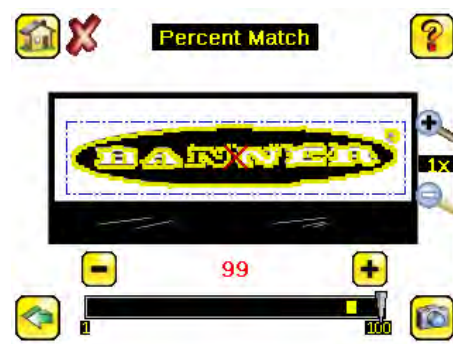

- Adjust the Rotation Range. The Rotation Range sets the expected rotation of parts or labels during an inspection. For example, a value of 45 means that the part may rotate 45 degrees in either direction from the reference part and still pass. Move the slider from 0 to 180 degrees. Note that the smaller the rotation range, the faster the inspection will run.



NOTE: Rotations Range and Percent Match work together. The higher the Percent Match, the lower the Rotation Range to pass. In the previous example a 99% match is too high for any rotation. In the next graphic the Percent Match has been lowered to 92% which will still fail a missing letter.

To set the Rotation Range:

- Move the slider at the bottom of the screen to the desired rotation. If you are verifying that a label is correctly applied to a container; that is, on straight, you will want to set a small rotation. If you want to make sure that the correct label is present no matter how the part is oriented in the Field of View, then the rotation range will be set to its maximum (90°, which is the setting for the Demo).

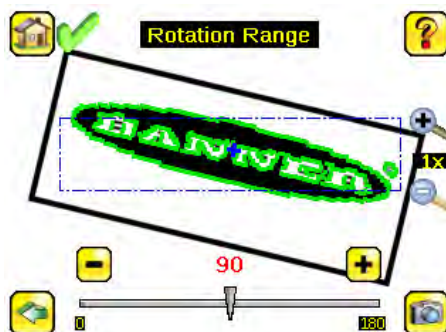

- Set the Pass Count parameter. The Minimum Pass Count is the minimum number of parts, labels, or features expected to fall within the specified criteria; the Maximum Pass Count is the maximum number expected to fall within the specified criteria. These settings are used to determine the pass or fail result of the inspection.
- Set the Minimum Pass Count and Maximum Pass Count as appropriate. In the Demo, both are set to to indicate the expected feature count is equal to 1. If the count is more than 1 or less than 1, the sensor will fail..

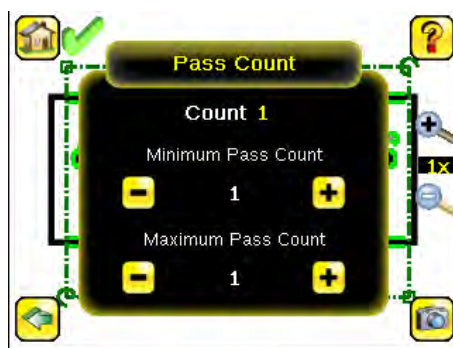

6. Test the complete range of good and bad samples to make sure that the sensor accepts good parts and rejects bad.
7. To complete the Match application setup, set triggering as appropriate for the application.



NOTE: When running a Match inspection, the sensor will look for any possible patterns to match anywhere within the Field of View.

5.4.1 Remote Teach

The Remote Teach function is a method of remotely updating inspection parameters while the iVu sensor is running. Remote Teach is only available when the iVu is configured as a Match sensor. The sequence of events for executing a Remote Teach are:

1. With the sensor Ready (see [Installation](#) on page 6), pulse the Remote Teach line.
2. The sensor recognizes that the Remote Teach line has been pulsed and waits for the next valid trigger.
3. At the next valid trigger, Ready goes inactive (the Green Ready LED shuts OFF), and the sensor acquires a new image.
4. The sensor learns the new pattern and performs the analysis.

5.5 Configuring a Sort Application



NOTE: By default, the Trigger is set to Internal, and will continuously trigger based on a time interval setting. This may make it more difficult to make adjustments while setting up the sensor. The best practice is as follows:

- Go to the Main Menu > Imager > Trigger menu and select External.

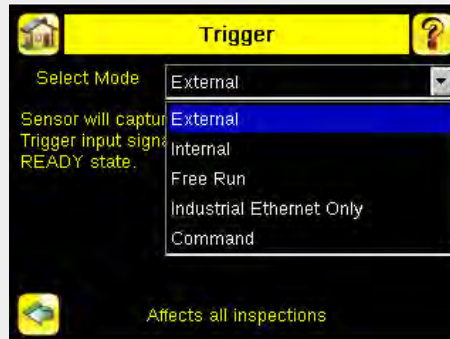

- Make sure there is no external trigger input.
- Use the Trigger icon in the lower-right of the screen to manually trigger the sensor to capture an image as you set up and test.
- Capture images of a range of samples to set up from the "worst" good part to the "best" bad part.

1. Make sure you use good parts for the inspection setup. Normally, each part will be centered in the field of view with the feature of interest surrounded by the Region of Interest (ROI).

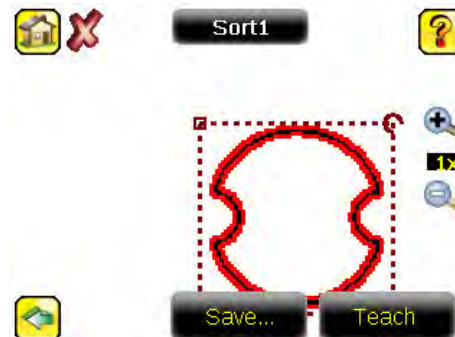

For the first part, select the ROI by clicking inside it. Move it, resize it, and rotate it by dragging the ROI or its corners. Once the feature of interest is within the ROI, click the Teach button. The feature will be highlighted in green.

2. Click the Save button to save the pattern to the first empty pattern storage slot.

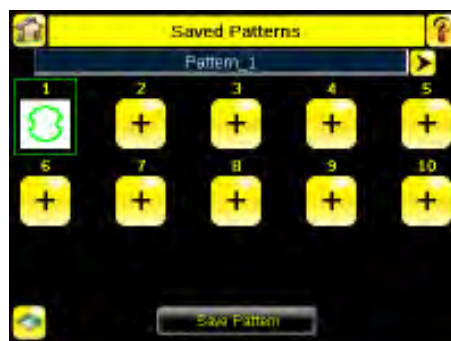

3. Set match criteria:



Tip: Use the short-cut menu in the upper-right of the screen to select an ROI-type.



Tip: For better results, make sure that the ROI bounds the image of the pattern as tightly as possible.

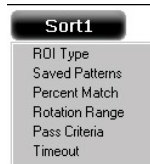

NOTE: When running a Sort inspection, the sensor will look for any possible patterns to match anywhere within the field of view.

- The Percent Match setting adjusts how closely the inspected part or label needs to match any of the ten stored patterns. The Percent Match scale is from 0 to 100, where 0 is the most tolerant and 100 is the least tolerant. Move the slider to the left or to the right to adjust the setting. For the best results, use a value from 50 to 90.



NOTE: When running a Sort inspection, the sensor will highlight in green any pattern matches that are within the specified Rotation Range and meet or exceed the value specified for Percent Match. Patterns that are within the specified Rotation Range and within approximately 20% below the specified value for Percent Match will be colored yellow.

- The Rotation Range sets the expected rotation of parts or labels during an inspection. For example, a value of 45 means that the part may rotate 45 degrees in either direction from the reference part and still pass. Move the slider from 0 to 180 degrees. Note that the smaller the rotation range, the faster the inspection will run.
4. Repeat these steps for subsequent patterns and store each pattern in an empty pattern storage slot.
 5. Set the Pass Criteria (assuming only two stored patterns):
 - Any Saved Pattern—Pass condition if the sensor matches either Pattern_1, Pattern_2, or both
 - All Saved Patterns—Pass condition if the sensor matches both Pattern_1 AND Pattern_2
 - Single Saved Pattern—Pass condition if the sensor matches either Pattern_1 OR Pattern_2, but NOT both
 - Specific Save Pattern (Must also select the saved pattern to match, for example, select Pattern_2)—Pass condition any time the sensor matches Pattern_2
 6.  Use the Manual Trigger, located in the lower-right corner of the screen, to test good and bad parts. Adjust settings as necessary and retest.

5.6 Configuring Motion

Main Menu > Inspection > Motion

This Motion menu shows up when Motion is Enabled under the Inspection Properties menu. Enable Motion when the part is expected to move or rotate. Motion settings involve selecting the number of edges to locate, adjusting sensitivity, and selecting whether or not rotation is enabled. These settings appear on the Inspection Menu after Motion is set to 'Enabled'. Motion is enabled only when Area and/or Blemish sensors are included in the inspection.

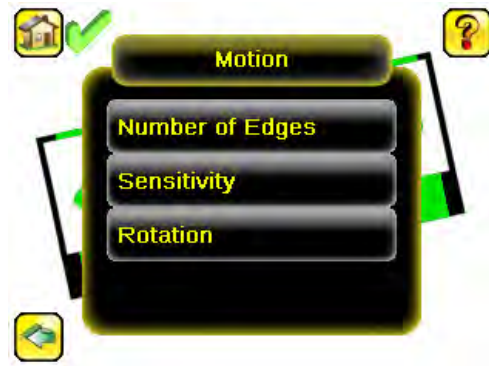

5.6.1 Number of Edges

Main Menu > Inspection > Motion > Number of Edges

On the Number of Edges screen, use the radio buttons to select One Edge or Two Edges. If One Edge is selected, motion is tracked in one direction (by default, horizontally); if Two Edges is selected, motion can be tracked horizontally and vertically.

5.6.2 Sensitivity

Main Menu > Inspection > Motion > Sensitivity

Sensitivity is used to fine-tune how sensitive the sensor is to finding a reference edge. The Sensitivity value helps account for light variations that might affect how well the sensor detects edges on inspected parts. The Sensitivity scale is from 0 to 100 where 0 means least sensitive and 100 means most sensitive. If set near 0, the sensor will only find very sharp edges with strong contrast. If set near 100, the sensor will find very dim or blurry edges, and may be unstable due to noise within the image.

5.6.3 Rotation

Main Menu > Inspection > Motion > Rotation

Rotation can be Enabled or Disabled. Select Enabled if the part can be expected to rotate during the inspection.

5.7 Configuring Multiple Sensors in the Inspection

Main > Inspection > Sensors > Add Sensor

Some applications require more than one sensor. New sensors can be added after an inspection has been created. Input parameters for each sensor can be configured individually.



1. Click on Add Sensor to display the list of sensor types that can be added into the inspection.

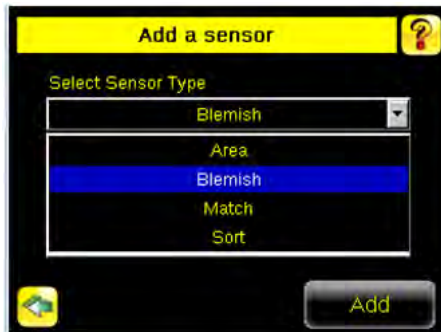





2. Click Add to add the selected sensor.



3. Click in the Sensor Setup area (Black button) to display the input parameter menu for that sensor.



4. Click on the yellow down-arrow button to access sensor management functions.

Icon	Function
	Move selected sensor up in the execution order
	Move selected sensor down in the execution order
	Edit name of selected sensor
	Delete selected sensor

After all the sensors are configured as required for the application, the inspection Pass/Fail criteria is determined by considering the results of the individual sensors. An inspection is considered as PASS if ALL sensors in the inspection pass. If any sensor fails, the inspection is marked as FAIL.

6 Communications Guide

6.1 iVu Plus Communication Summary of Ethernet and Serial

The iVu Plus communicates with other devices via Ethernet or a UART serial communications port (RS-232). In order to establish an Ethernet connection to the sensor, the external device must be configured with the correct IP address and TCP port to communicate. To use the serial communications connection, port settings for baud rate, data bits, parity, and stop bits must be configured on the iVu Plus to match the settings of the external device.

6.1.1 Communication Channels

The iVu Plus TG supports up to four communications channels. To access the channels, go to Main Menu > System > Communications.

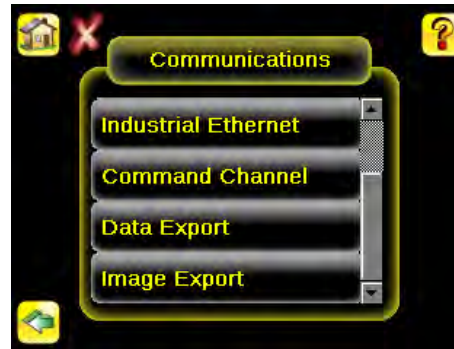

- Command Channel—a bi-directional communication protocol that currently supports ASCII and enables other devices to remotely control the iVu Plus sensor and access sensor results
- Industrial Ethernet—a bi-directional communication channel that allows the user to control the sensor and access sensor results using Ethernet/IP, Modbus/TCP, or PCCC protocol
- Data Export—used to export selected inspection data to a remote device
- Image Export—used to export inspection images to a remote device

Data export and command channel can be configured for either Ethernet or Serial I/O (but not both); image export is only available over Ethernet. The table below briefly summarizes valid communication channel configuration options.

Command Channels	Scenario #1		Scenario #2		Scenario #3	
	Ethernet	Serial I/O	Ethernet	Serial I/O	Ethernet	Serial I/O
Command Channel	Yes	No	No	Yes	Yes	No
Industrial Ethernet	Yes	No	Yes	No	Yes	No
Data Export	Yes	No	Yes	No	No	Yes
Image Export	Yes	No	Yes	No	Yes	No

6.1.2 Industrial Ethernet

Main Menu > System > Communications > Industrial Ethernet

The iVuPlus device can be controlled or monitored over Industrial Ethernet using Ethernet/IP, Modbus/TCP or PCCC protocols. This document will help you to set up the iVu Plus in the desired configuration and provide you with information you will need to connect to the master device (PLC, HMI, etc.).

6.1.3 Command Channel

The iVu Plus TG command channel is a bi-directional communication protocol that currently supports ASCII via either Ethernet or the RS-232 serial interface, and enables other devices to remotely control the iVu sensor and access sensor results.

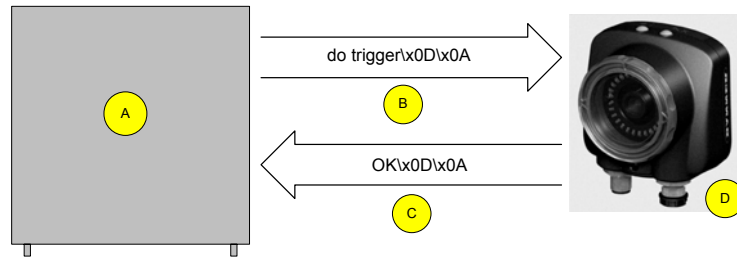

- A Control Device, which can be a PLC, PC program, or a terminal
- B Request Frame
- C Response Frame
- D iVu Plus TG Sensor

The following are some of the functionality available via the command channel:

- Get sensor information (such as version and sensor name)
- Control "discrete" I/O (such as trigger and teach)
- Get sensor results (such as sensor status)
- Change the running inspection

Command Channel Sample Application

The iVu Plus TG installation CD has a Command Channel sample application that provides an easy interface to execute commands. In a production environment, you will need to create your own application for bi-directional communication with the sensor.

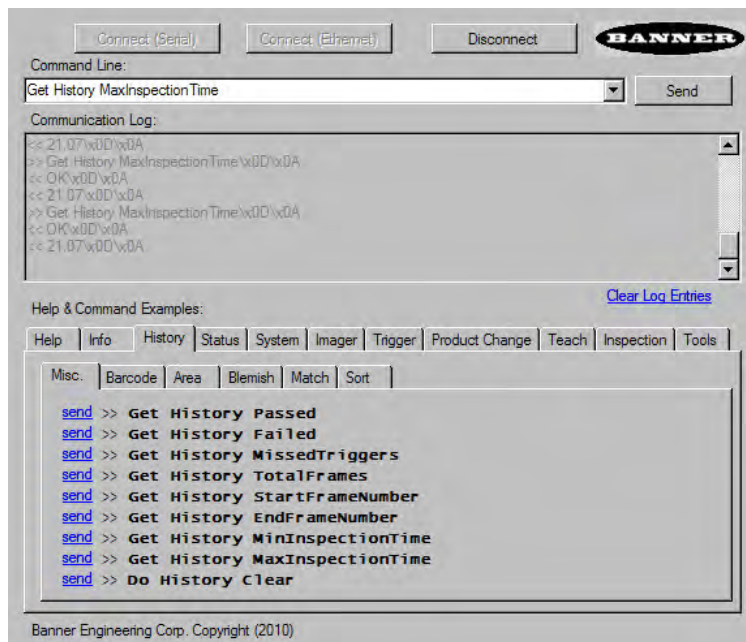

6.1.4 Data Export

The iVu Plus sensor provides for exporting user-selected inspection data via either Ethernet or the RS-232 serial interface. Inspection data that can be exported includes:

- Pass/Fail Output
- Inspection Name
- Sensor Result
 - Name

- Pass/Fail
- Sensor Result (see [Table 6](#) on page 75 for additional information)
- Inspection Time (ms)

Table 6: Sensor Results

Sensor Type	Data to Export
Area	Count
	Area Range
Blemish	Count
	Edge Length Range
Match	Count
	Percent Match
Sort	Count
	Percent Match
	All Found Pattern Numbers
	All Found Pattern Names

Data export settings apply to all inspections sensor-wide. If items are selected that are not part of the current inspection, those items are ignored.

Sample Application

The iVu Plus TG installation CD has a Data Export sample application that provides for viewing exported data while setting up the sensor, etc. In a production environment, you will need to create your own application to process data exported from the sensor.

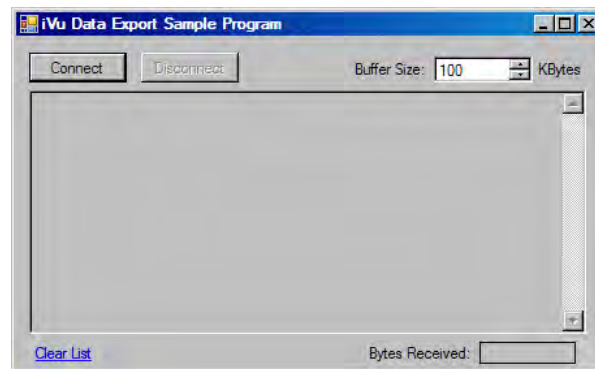

6.1.5 Image Export

Image export is only supported on Ethernet ports. Inspection images are a maximum 320×240 8-bits per pixel grayscale images in Windows BMP format that represent all the data in a full Field of View (FOV).

Each exported image is comprised of a header (64 bytes) followed by the image data (approximately 78K). All 16- and 32-bit numeric entries are little endian.

The header includes the following information:

Byte Offset	Field	Size in Bytes	Data Type	Description
0-15	Header Prefix	16	char	"IVU PLUS IMAGE"
16-19	Header Version	4	UInt32	1
20-23	Image Size	4	UInt32	Number of bytes (Windows BMP image)

Byte Offset	Field	Size in Bytes	Data Type	Description
24-27	Image Frame Number	4	UInt32	Most recently snapped image frame number
28-29	Image Width	2	UInt16	320 (max)
30-31	Image Height	2	UInt16	240 (max)
32-33	Image Format	2	UInt16	0: Bitmap, 1: JPEG
34-63	Reserved	32	byte	Reserved for future use



NOTE: If FOV's are adjusted so that they are smaller, the bitmaps will also be smaller.

Image Export Sample Application

The iVu Plus TG installation CD has a Image Export sample application that provides a way to save exported images. In a production environment, you will need to write your own application to process exported images, for example to display them on an HMI or to save them to disk.

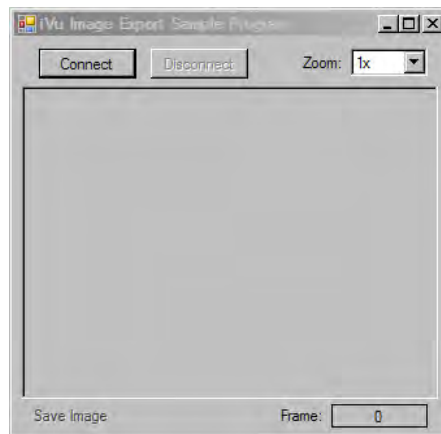

6.2 Enabling Communications

6.2.1 Setting Up Ethernet Communications

Configure both the PC and the sensor using the following instructions.

Windows XP

1. Open Network Properties on the PC (right-click on the Network Neighborhood icon).
2. On the Local Area Connection, right-click on Properties.
3. In the dialog, click on Internet Protocol (TCP/IP) and click the Properties button.

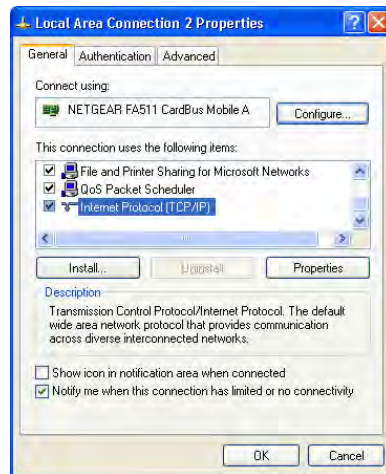

4. In the Internet Protocol (TCP/IP) Properties dialog, select Use the following IP address and make sure that the IP address is 192.168.0.2, and the subnet mask is 255.255.255.0.

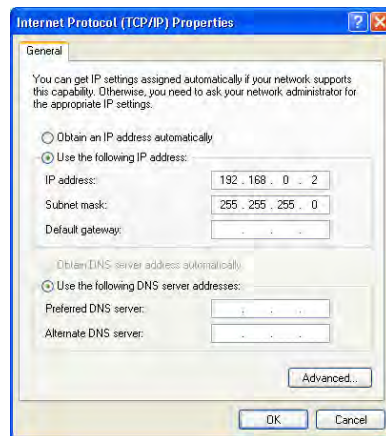

Windows 7

1. Open Network Connections by clicking on the Start button, then selecting the Control Panel followed by Network and Internet, and clicking Manage network connections.
2. Right-click the connection you want to change, then click Properties. If you are prompted for an administrator password or confirmation, type the password or provide confirmation.
3. In the Networking dialog, click on Internet Protocol Version 4 (TCP/IPv4) and click the Properties button.

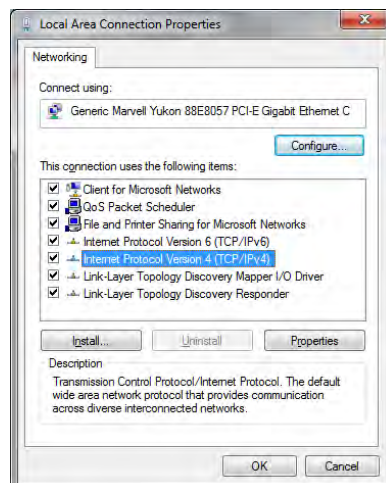

4. In the Internet Protocol (TCP/IPv4) Properties dialog, select Use the following IP address and make sure that the IP address is 192.168.0.2, and the subnet mask is 255.255.255.0.

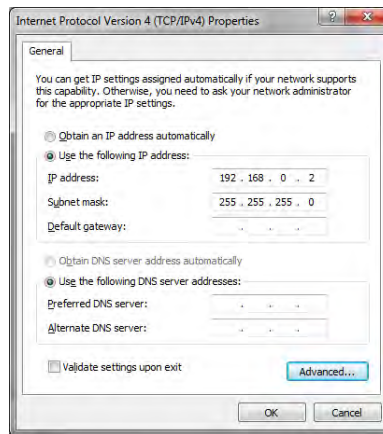

Sensor Setup for Ethernet Communications

1. Go to Main Menu > System > Communications > Ethernet I/O and make sure that the sensor is configured as shown below.

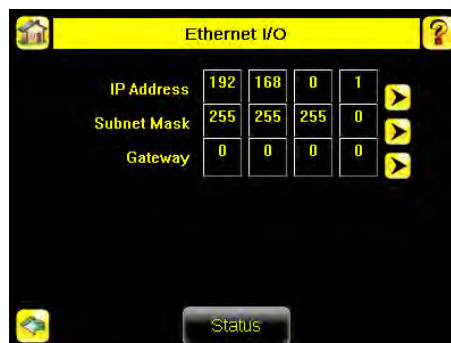

2. To enable the command channel over Ethernet:
 - a. Go to Main Menu > System > Communications > Command Channel > Connection, and select Ethernet [IP Port # 32000].

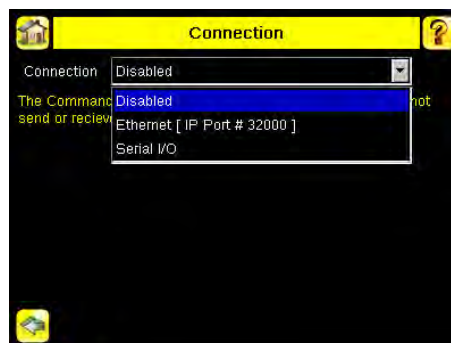

- b. Configure the field and end-of-frame delimiters. Go to Main Menu > System > Communications > Command Channel > Delimiters.

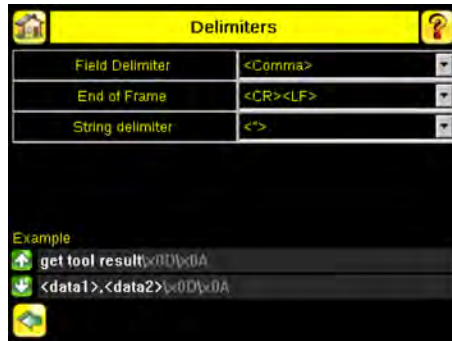

Valid end-of-frame delimiters are: <comma>, <colon>, <semicolon>, <CR>, <CR><LF>, <LF><CR>, or <ETX>.

- c. Verify that the iVu receives and transmits data correctly.
- 3. To enable Data Export over Ethernet:
 - a. Go to Main Menu > System > Communications > Data Export > Connection and select Serial I/O from the drop-down.

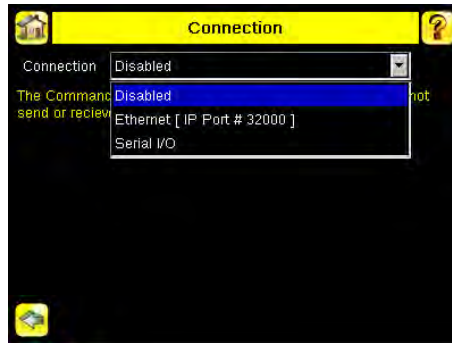

- b. Go to Main Menu > System > Communications > Data Export > Data To Export and select the inspection data to export.

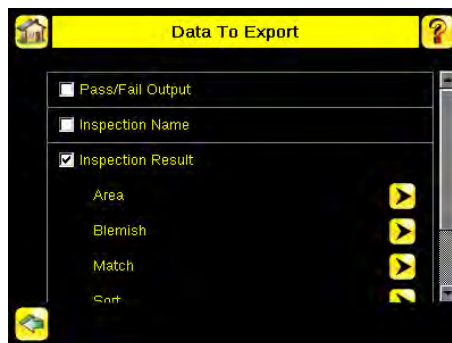

- c. Go to Main Menu > System > Communications > Data Export > Output Format and select the Start String, Delimiter, and End String.

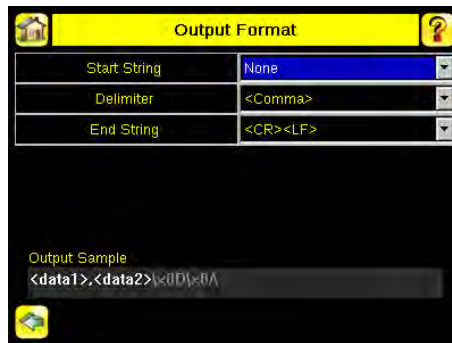

d. Go to Main Menu > System > Communications > Data Export > Advanced.



During the Data and Image export operation the sensor's output channels might become full. This can occur if the sensor is producing export data (frames) faster than the data can be exported from the device (due to bandwidth limitations) or faster than the client is reading the channel export data.

This setting affects how the sensor will behave in this situation.

- Select Hold READY to ensure that all frames are transmitted. In this case, the READY signal will remain inactive (sensor is busy) until the new frame has been added to the channel for transmission. Triggers might be missed during this time.
- Select Do not hold READY to cause the sensor to discard the new frame if the channel is full and thus activate the READY signal immediately after the current inspection is complete. In this case, the discarded frames will not be transmitted.

Communications Channel Ports

The following are the default Ethernet port settings for the communications channels:

- Command Channel — 32200
- Data Export — 32100
- Image Export — 32000

6.2.2 Setting Up Serial Communications

1. Electrically connect the control device and the iVu sensor. On the iVu, the pins/wire colors used for serial communications via RS-232 are shown in the table below.

Table 7: iVu RS-232 Connections

Pin #	Wire Color	Description
10	Light-Blue	TX
11	Black	Signal Ground
12	Violet	RX

2. Configure port settings (baud rate, data bits, parity, and stop bits) on the iVu to match the settings on the control device. Go to Main Menu > System > Communications > Serial I/O.

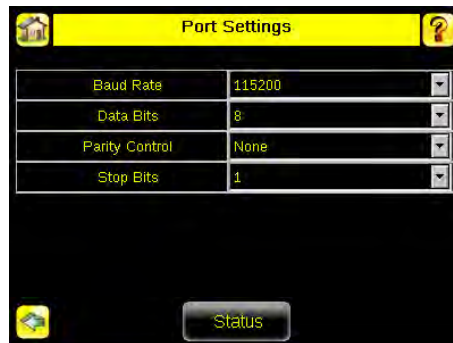

3. To enable the command channel over the serial connection:
 - a. Go to Main Menu > System > Communications > Command Channel > Connection and select Serial I/O.
 - b. Configure the field and end-of-frame delimiters. Go to Main Menu > System > Communications > Command Channel > Delimiters.

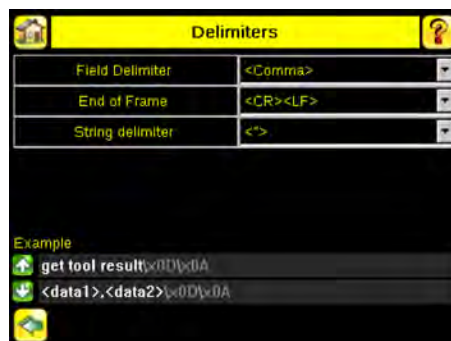

Valid end-of-frame delimiters are: <comma>, <colon>, <semicolon>, <CR>, <CR><LF>, <LF><CR>, or <ETX>.

- c. Optionally, if you want to trigger the iVu from the control device, set the trigger mode to Command (go to Main Menu > Imager > Trigger and select Command from the drop-down).

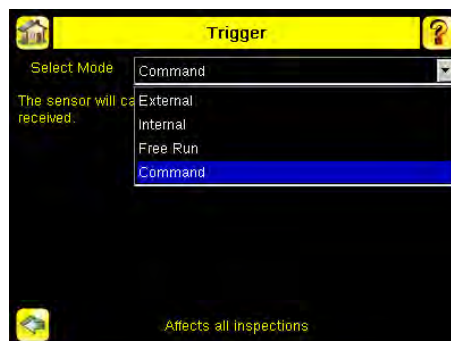

- d. Verify that the iVu receives and transmits data correctly.
4. To enable Data Export over the serial connection:
 - a. Go to Main Menu > System > Communications > Data Export > Connection and select Serial I/O from the drop-down.

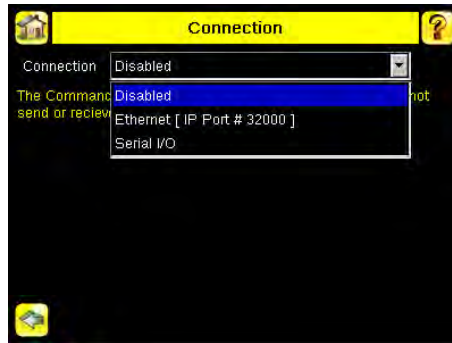

- b. Go to Main Menu > System > Communications > Data Export > Data To Export and select the inspection data to export.

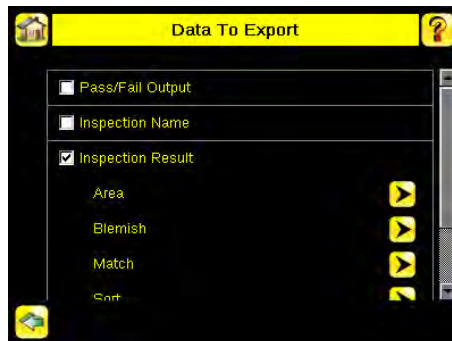
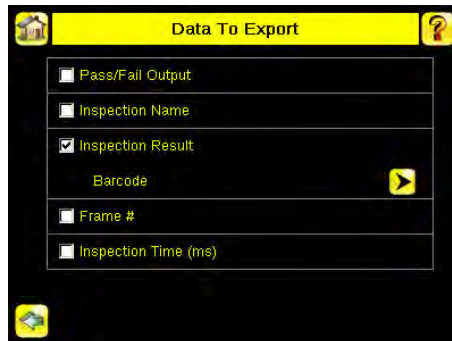

- c. Go to Main Menu > System > Communications > Data Export > Output Format and select the Start String, Delimiter, and End String.

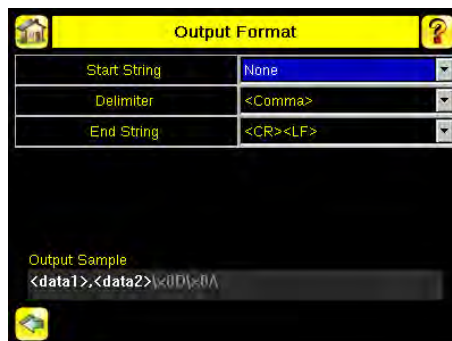

- d. Go to Main Menu > System > Communications > Data Export > Advanced.



During the Data and Image export operation the sensor's output channels might become full. This can occur if the sensor is producing export data (frames) faster than the data can be exported from the device (due to bandwidth limitations) or faster than the client is reading the channel export data.

This setting affects how the sensor will behave in this situation.

- Select Hold READY to ensure that all frames are transmitted. In this case, the READY signal will remain inactive (sensor is busy) until the new frame has been added to the channel for transmission. Triggers might be missed during this time.
- Select Do not hold READY to cause the sensor to discard the new frame if the channel is full and thus activate the READY signal immediately after the current inspection is complete. In this case, the discarded frames will not be transmitted.

6.3 Testing and Troubleshooting iVu Plus Communications

6.3.1 Understanding the Communication Log

The iVu Plus sensor includes the following Communication Logs:

- Command Channel Log that can be used to ensure that commands are properly formed (syntax is correct), and provides a history of commands issued along with responses to these commands. To access the Command Channel Log, go to Main Menu > Logs > Communication Logs > Command Channel
- Data Export and Image Output logs that are purely output logs (that is, there is no receive activity to log)







Some notes about the logs:

- To see an expanded view of each entry, click on the small right-triangle control on each entry
- To save the log, click the save icon. The saved communication log can be loaded into the emulator for troubleshooting offline

The table below describes the icons used in the Communication Log, the up-arrow indicates an incoming request to the iVu from the control device; the down-arrow indicates an outgoing response from the iVu to the control device.

Icon	Description
	Port opened.

Icon	Description
	Port closed.
	Indicates that the command has been processed without errors.
	Indicates that the incoming entry is stalled (no new bytes), or end-of-frame delimiter was not received, or client is not reading data on ethernet.
	If the response frame contains an error or is dropped, the log entry icons for the request and the response frames will be colored red, and the displayed error count will increment by one.
	If the command takes a long time to process, the last long entry will change to an hourglass (for example, during trigger of long inspections).

For Ethernet channels:

- The channel's log will show an Enabled entry that indicates which port is being listened to
- When a client connects, a log entry is added that indicates which IP address connected
- When a client closes the connection, a log entry indicates that the channel is no longer being listened to

6.3.2 Ethernet I/O

Ethernet I/O Status

The Ethernet I/O Status screen can be used to verify that the Ethernet wiring has been correctly set up. In addition to determining if the link has been established, incoming and outgoing traffic can be monitored.

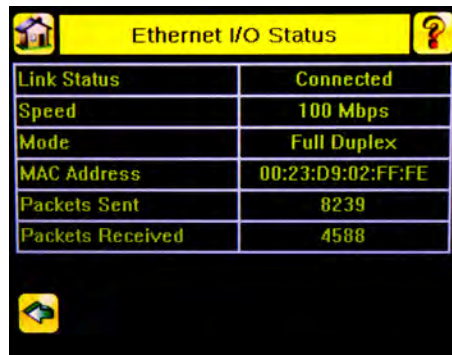

6.3.3 Serial I/O

Using the Port Status Screen for Testing RS-232 Communications

The Port Status screen can be used to ensure data is entering and exiting the sensor. This can be useful for debugging issues such as improper wiring, mismatched baud rates, or other serial I/O issues. To access the Port Status screen, go to Main Menu > System > Communications > Serial I/O and click on the Status button.

- The upper field shows the bytes received (request frame) on the iVu from the control device.
- The lower field shows the bytes sent (response frame) from the iVu to the control device.





3. If the byte count does not match, re-verify that the settings on both devices match exactly. If no bytes are received, re-check the wiring.

If the correct response frame is received, then basic electrical and port settings are correct.

6.4 Command Channel Primer

6.4.1 Command Channel Commands

All iVu command channel request command frames use the following syntax:

```
>> command group item value<EOF>
```

Notes

<EOF> is the end-of-frame delimiter. See below for a description.

All commands are in ASCII and are case-insensitive

command

An action to be performed on a particular iVu group; for example, get, set, do, login, or logout.

group

Identifies the iVu group that the command should act upon; for example, info, system, trigger, or bcr_input.

item

Further qualifies the action by specifying an item within the identified group; for example, comparedata or status.

value

For set commands, this identifies the data that must be set for the specified group item.

Note: Item is not used with get commands.

<EOF>

Identifies the end-of-frame for the command so that the iVu knows to begin processing. The iVu will return a response that includes the end-of-frame delimiter. The options for the <EOF> are set in the iVu Serial I/O menu, and are as follows:

- <comma>
- <colon>
- <semicolon>
- <CR>
- <CR><LF>
- <LF><CR>
- <ETX>



NOTE: When data is displayed on iVu screens such as the Port Status screen, printable delimiters are displayed as expected. Non-printable characters, such as <CR> are displayed in hex notation (\x0D).

Command Flow

The command flow should be such that a new command request should not be issued until the iVu command channel acknowledges the previous command request.

For example, the following is a series of command requests and responses. The first request sets the trigger mode to command and, once the sensor responds with an "OK," the next command request is issued to do (or execute) the trigger.

```
>> set trigger mode command\x0D\x0A
<< OK\x0D\x0A
>> do trigger\x0D\x0A
<< OK\x0D\x0A
```

String Delimiters and Escaping

By default setting, all strings used in commands are enclosed in quotation marks (""). All text in quotes is part of the command. Quotes (") or back-slashes (\) that are part of the string must be escaped with a back-slash. For example:

```
"abc\"def\"ghi\"jkl"
```

Set the String Delimiter parameters to 'None' if strings should not be enclosed in quotation marks.

Command Channel Command Synopsis

There are a number of general types of commands to do, set, and get sensor data.

Command Channel Response Frames

The iVu responds to all request frames with one or two responses depending on the type of command.

Do commands

All do commands are followed by one response that identifies the command status. For example:

```
>> do trigger\x0D\x0A
<< OK\x0D\x0A
```

Get commands

All get commands are followed by two responses: the first identifies the status of the command, and the second contains the retrieved information. For example:

```
>> get bcr_input comparedata\x0D\x0A
<< OK\x0D\x0A
<< "012345ABCDEF"\x0D\x0A
```

Set commands

All set commands are followed by one response that identifies the command status. For example:

```
>> set bcr_input comparedata "012345ABCDEF"\x0D\x0A
<< OK\x0D\x0A
```

Command Channel Command Status

The command status is either OK or ERROR. If OK, then the command has fully and successfully completed. If an error is returned it is in the form *ERROR nnnnn_ERROR_IDENTIFIER* (for example ERROR 10001_COMMAND_NOT_RECOGNIZED). Refer to [Command Channel Error Codes](#) on page 96 for a list of errors.

6.4.2 Conventions Used for Examples

There are a number of command channel examples included here, and the following are the conventions used in the examples:

- All examples use <CR><LF> for the end-of-frame delimiter, and this delimiter is always denoted in hex (\x0D\x0A) since that is what is displayed in the iVu logs and, for example, the Port Status screen.
- All commands are in bold text.
- For each example, a command request to the iVu sensor is prefaced with a >>, and a command response frame from the iVu sensor is prefaced by a << as shown below. These are only used to make the documentation clearer.

```
>> get info companyname\x0D\x0A
<< OK\x0D\x0A
<< "Banner Engineering Corp."\x0D\x0A
```

6.4.3 Examples

How to Trigger the Sensor and Retrieve Inspection Data using the Command Channel

This example is based on a sort inspection. To trigger the sensor and retrieve inspection data, do the following

1. Make sure that the Command Channel is enabled using either Ethernet or Serial I/O (Main Menu > System > Communications > Command Channel > Connection).
2. Set Trigger to Command. Go to the Main Menu > Imager > Trigger screen, and from the drop-down select Command.
3. Issue a trigger command as follows:

```
>> do trigger\x0D\x0A
<< OK\x0D\x0A
```

4. Check that the inspection passed.

```
>> get inspection status\x0D\x0A
<< OK\x0D\x0A
<< Pass\x0D\x0A
```

5. Get the pattern names that are stored in the iVu sensor.

```
>> get sort_result patternnames\x0D\x0A
<< OK\x0D\x0A
<< "pattern_1", "pattern_2"\x0D\x0A
```

How to Execute a Product Change Using the Command Channel

1. Make sure that the Command Channel is enabled using either Ethernet or Serial I/O (Main Menu > System > Communications > Command Channel > Connection).
2. Get all the stored inspection names.

```
>> get productchange inspectionnames\x0D\x0A
<< OK\x0D\x0A
<< "Inspection 1", "Inspection 2", "Inspection 3"\x0D\x0A
```

3. Execute a product change.

```
>> do productchange "inspection2"\x0D\x0A
<< OK\x0D\x0A
```

4. Check that the inspection passed.

```
>> get inspection status\x0D\x0A
<< OK\x0D\x0A
<< Pass\x0D\x0A
```

6.4.4 Command Channel Reference

Info Command Group

Command	Group	Item	Description
Get	Info	CompanyName	The company name as a string.
Get	Info	ModelNumber	The sensor model number as a string.
Get	Info	FirmwareVersion	The sensor firmware version as a string.
Get	Info	SerialNumber	The sensor serial number as a string.
Get	Info	Name	The sensor name as a string.
Get	Info	BootNumber	The number of sensor bootups.
Get	Info	UpTimer	The elapsed time the sensor has been running in the format hh:mm:ss:msec.
Get	Info	HourCount	The number of hours the sensor has been running.
Get	Info	RemoteConnected	The remote display connected status as a boolean value (true or false).

Command	Group	Item	Description
Get	Info	RemoteModelNumber	The model number of the remote display as a string.
Get	Info	RemoteSerialNumber	The serial number of the remote display as a string.

Examples

```
>> get info companyname\x0D\x0A
<< OK\x0D\x0A
<< "Banner Engineering Corp."\x0D\x0A
```

```
>> get info bootnumber\x0D\x0A
<< OK\x0D\x0A
<< 42\x0D\x0A
```

```
>> get info uptimer\x0D\x0A
<< OK\x0D\x0A
<< 4:42:42:324\x0D\x0A
```

System Command Group

Command	Group	Item	Description
Do	System	Reboot	Reboots the sensor. Pre-empts other commands except Save.
Do	System	Save	Saves inspection and configuration parameters. Blocks until finished. Should be used sparingly.
Get	Ethernet	IPAddress	Get the current active IP address of the sensor as a string.
Get	Ethernet	SubnetMask	Get the current active subnet mask of the sensor as a string.
Get	Ethernet	Gateway	Get the current active Gateway address of the sensor as a string.
Set	Ethernet	IPAddress	Set IP address of the sensor. A valid IP address must be supplied as a string (for example: 192.168.0.1). A 'Reboot' command from the command channel must follow in order to make the new IP address effective. You may also set new Subnet Mask and Gateway address as required before a 'Reboot' command is sent to the sensor.
Set	Ethernet	SubnetMask	Set new subnet mask. A 'Reboot' command is required to be sent from the command channel in order to make the new mask effective.
Set	Ethernet	Gateway	Set new Gateway IP address. A 'Reboot' command is required to be sent from the command channel to make the new address effective.

Examples

```
>> do system save\x0D\x0A
<< OK\x0D\x0A
```

Status Command Group

Command	Group	Item	Description
Get	Status	Ready	Flag indicating whether the system is ready to trigger (true) or busy (false).
Get	Status	SystemError	Flag indicating whether a system error is active (true) or cleared (false).
Do	Status	ClearSystemError	Clears the system error LED and sets the internal flag to false.

Examples

```
>> get status ready\x0D\x0A
<< OK\x0D\x0A
<< True\x0D\x0A
```

```
>> get status systemerror\x0D\x0A
<< OK\x0D\x0A
<< False\x0D\x0A
```

```
>> do status clearsystemerror\x0D\x0A
<< OK\x0D\x0A
```

Trigger Command Group

Command	Group	Item	Description
Get	Trigger	Mode	Sets trigger mode to one of the valid trigger modes for the sensor.
Set	Trigger	Mode	Sets trigger mode to one of the valid trigger modes for the sensor.
Do	Trigger		Initiates a single trigger. The sensor does not transmit a response until the sensor has completed the action.

Examples

```
>> set trigger mode command\x0D\x0A
<< OK\x0D\x0A
```

```
>> get trigger mode\x0D\x0A
<< OK\x0D\x0A
<< Command\x0D\x0A
```

```
>> do trigger\x0D\x0A
<< OK\x0D\x0A
```

Imager Command Group

Command	Group	Item	Description
Get	Imager	Gain	The sensor's value used to electronically brighten all image pixels. This value can be modified using the sensor's touchscreen. This remotely modified value is not persisted to the sensor's permanent memory. The 'Save' operation is required to persist this value.
Set	Imager	Gain	The sensor's value used to electronically brighten all image pixels. This value can be modified using the sensor's touchscreen. This remotely modified value is not persisted to the sensor's permanent memory. The 'Save' operation is required to persist this value.
Get	Imager	Exposure	The sensor's value used to control the amount of time the imager is allowed to gather light for the image. This value can be modified using the sensor's touchscreen. This remotely modified value is not persisted to the sensor's permanent memory. The 'Save' operation is required to persist this value.

Command	Group	Item	Description
Set	Imager	Exposure	The sensor's value used to control the amount of time the imager is allowed to gather light for the image. This value can be modified using the sensor's touchscreen. This remotely modified value is not persisted to the sensors permanent memory. The 'Save' operation is required to persist this value.

Examples

```
>> get imager exposure\x0D\x0A
<< OK\x0D\x0A
<< Command\x0D\x0A
```

```
>> set imager exposure"11900"\x0D\x0A
<< OK\x0D\x0A
```

Teach Command Group

Command	Group	Item	Description
Do	Teach	NextTrigger	This commands forces the sensor to perform the Remote Teach operation on the next trigger. This command can be performed using the sensor's touchscreen.

Examples

```
>> do teach\x0D\x0A
<< OK\x0D\x0A
```

ProductChange Command Group

Command	Group	Item	Description
Do	ProductChange	[Name]	Forces the sensor to switch to the specified inspection. The sensor does not transmit a response until the sensor has completed the action. Inspections results will be invalid until the next trigger.
Get	ProductChange	InspectionNames	List of all inspections stored in the sensor.

Examples

```
>> get productchange inspectionnames\x0D\x0A
<< OK\x0D\x0A
```

```
>> do productchange "inspection2"\x0D\x0A
<< OK\x0D\x0A
```

History Command Group

Command	Group	Item	Description
Get	History	Passed	The number of passed inspections.
Get	History	Failed	The number of failed inspections.
Get	History	MissedTriggers	The number of missed triggers.

Command	Group	Item	Description
Get	History	TotalFrames	The total number of inspections since the history was last cleared.
Get	History	MinInspectionTime	The minimum elapsed time (msec) of the inspection.
Get	History	MaxInspectionTime	The maximum elapsed time (msec) of the inspection.
Do	History	Clear	Clears all history fields (for example pass, fail, sensor history, etc.).

Examples

```
>> get history passed\x0D\x0A
<< OK\x0D\x0A
<< 13\x0D\x0A
```

```
>> get history startframenumbers\x0D\x0A
<< OK\x0D\x0A
<< 3\x0D\x0A
```

```
>> do history clear\x0D\x0A
<< OK\x0D\x0A
```

Inspection Command Group

Command	Group	Item	Description
Get	Inspection	Status	This status of the most recent inspection either Pass, Fail, or Idle (no triggers).
Get	Inspection	Name	The name of the active inspection.
Get	Inspection	FrameNumber	The most recent inspection frame number.
Get	Inspection	ExecutionTime	The most recent inspection execution time in msec.

Examples

```
>> get inspection status\x0D\x0A
<< OK\x0D\x0A
<< Fail\x0D\x0A
```

```
>> get inspection executiontime\x0D\x0A
<< OK\x0D\x0A
<< 37.739\x0D\x0A
```

AREA_RESULT Command Group

Command	Group	Item	Description
Get	AREA_RESULT	Count	The number of detected areas.
Get	AREA_RESULT	MinArea	The size of the smallest detected area.
Get	AREA_RESULT	MaxArea	The size of the largest detected area.

Examples

```
>> get area_result count\x0D\x0A
<< OK\x0D\x0A
<< 2\x0D\x0A
```

```
>> get area_result minarea\x0D\x0A
<< OK\x0D\x0A
<< 7665\x0D\x0A
```

AREA_HISTORY Command Group

Command	Group	Item	Description
Get	AREA_HISTORY	MinCount	The minimum number of detected areas, since history was last cleared.
Get	AREA_HISTORY	MaxCount	The maximum number of detected areas, since history was last cleared.
Get	AREA_HISTORY	MinArea	The minimum detected area value, since history was last cleared.
Get	AREA_HISTORY	MaxArea	The maximum detected area value, since history was last cleared.

Examples

```
>> get area_history mincount\x0D\x0A
<< OK\x0D\x0A
<< 1\x0D\x0A
```

```
>> get area_history minarea\x0D\x0A
<< OK\x0D\x0A
<< 7665\x0D\x0A
```

BLEMISH_RESULT Command Group

Command	Group	Item	Description
Get	BLEMISH_RESULT	Count	The number of detected blemishes.
Get	BLEMISH_RESULT	MinEdgeLength	The minimum detected blemish edge length.
Get	BLEMISH_RESULT	MaxEdgeLength	The maximum detected blemish edge length.

Examples

```
>> get blemish_result count\x0D\x0A
<< OK\x0D\x0A
<< 4\x0D\x0A
```

```
>> get blemish_result minedgelenlength\x0D\x0A
<< OK\x0D\x0A
<< 22\x0D\x0A
```

BLEMISH_HISTORY Command Group

Command	Group	Item	Description
Get	BLEMISH_HISTORY	MinCount	The minimum number of detected blemishes, since history was last cleared.

Command	Group	Item	Description
Get	BLEMISH_HISTORY	MaxCount	The maximum number of detected blemishes, since history was last cleared.
Get	BLEMISH_HISTORY	MinEdgeLength	The minimum detected blemish edge length, since history was last cleared.
Get	BLEMISH_HISTORY	MaxEdgeLength	The maximum detected blemish edge length, since history was last cleared.

Examples

```
>> get blemish_history count\x0D\x0A
<< OK\x0D\x0A
<< 1\x0D\x0A
```

```
>> get blemish_history maxcount\x0D\x0A
<< OK\x0D\x0A
<< 6\x0D\x0A
```

MATCH_RESULT Command Group

Command	Group	Item	Description
Get	MATCH_RESULT	Count	The number of detected matches.
Get	MATCH_RESULT	MinPercentMatch	The minimum detected match percentage.
Get	MATCH_RESULT	MaxPercentMatch	The maximum detected match percentage.

Examples

```
>> get match_result count\x0D\x0A
<< OK\x0D\x0A
<< 1\x0D\x0A
```

```
>> get match_result maxpercentmatch\x0D\x0A
<< OK\x0D\x0A
<< 6\x0D\x0A
```

MATCH_HISTORY Command Group

Command	Group	Item	Description
Get	MATCH_HISTORY	MinCount	The minimum number of detected matches, since history was last cleared.
Get	MATCH_HISTORY	MaxCount	The maximum number of detected matches, since history was last cleared.
Get	MATCH_HISTORY	MinPercent	The minimum detected match percentage, since history was last cleared.
Get	MATCH_HISTORY	MaxPercent	The maximum detected match percentage, since history was last cleared.

Examples

```
>> get match_history count\x0D\x0A
<< OK\x0D\x0A
<< 1\x0D\x0A
```

```
>> get match_history maxcount\x0D\x0A
<< OK\x0D\x0A
<< 6\x0D\x0A
```

SORT_RESULT Command Group

Command	Group	Item	Description
Get	SORT_RESULT	Count	The number of detected sort patterns.
Get	SORT_RESULT	MinPercentMatch	The minimum detected sort pattern match percentage.
Get	SORT_RESULT	MaxPercentMatch	The maximum detected sort pattern match percentage.
Get	SORT_RESULT	PatternNumbers	Listing of detected patterns by pattern number.
Get	SORT_RESULT	PatternNames	Listing of detected patterns by pattern name.

SORT_HISTORY Command Group

Command	Group	Item	Description
Get	SORT_HISTORY	MinCount	The minimum number of detected sort patterns, since history was last cleared.
Get	SORT_HISTORY	MaxCount	The maximum number of detected sort patterns, since history was last cleared.
Get	SORT_HISTORY	MinPercent	The minimum detected sort pattern match percentage, since history was last cleared.
Get	SORT_HISTORY	MaxPercent	The maximum detected sort pattern match percentage, since history was last cleared.

Examples

```
>> get sort_history mincount\x0D\x0A
<< OK\x0D\x0A
<< 1\x0D\x0A
```

```
>> get sort_history maxcount\x0D\x0A
<< OK\x0D\x0A
<< 6\x0D\x0A
```

6.4.5 Multiple Sensors Inspection

When having more than one sensor in the inspection, all `SensorType_Result` and `SensorType_History` related commands must include the *Sensor Name* in "< >" brackets.

Examples

```
>> get area_result <Area1> count\x0D\x0A
<< OK\x0D\x0A
<< 7665\x0D\x0A
```

Notice that <Area1> is the sensor name of an Area Sensor Type in the current inspection.

```
>> get blemish_history <Blemish1> minedgelenlength\x0D\x0A
<< OK\x0D\x0A
<< 22\x0D\x0A
```

Notice that <Blemish1> is the sensor name of a Blemish Sensor Type in the current inspection.

6.4.6 Command Channel Command Status Register

The command status is a verification of the command type.

Command Status	Value (16-bit integer)
Unknown	0
Read	1
Write	2
Execute	3

6.4.7 Command Channel Error Codes

Table 8: Plus TG Command Channel Error Codes

Numeric ID	Text ID	Description
00000	SUCCESS	Command processed successfully
10000	EMPTY_FRAME_RECEIVED	Indicates that the request was empty. The command channel requires a command, any arguments, and an end-of-frame delimiter.
10001	COMMAND_NOT_RECOGNIZED	The command specified is not recognized
10100	GROUP_MISSING	A Group ID must be specified immediately after the command
10101	GROUP_NOT_FOUND	The specified Group ID is invalid / unknown
10102	GROUP_ITEM_MISSING	A Group Item ID must be specified immediately after the Group ID
10103	GROUP_ITEM_NOT_FOUND	The specified Group Item ID is invalid / unknown
10152	NOT_READABLE	Attempt to get a value that is not readable
10153	NOT_WRITEABLE	Attempt to set a value that is not writeable
10250	NOT_A_METHOD	Method ID specified is not a method
10251	WRONG_ARGUMENT_COUNT	Total method arguments specified do not match method
10252	COMMAND_NOT_FINISHED	Attempt to issue command when a previous command has not finished
10300	INVALID_ARGUMENT_TYPE	Item ID specified must be a item (not a group or method)
10301	DATA_VALUE_MISSING	Command missing item's data value
10350	ARGUMENTS_DETECTED	Get command received with unneeded arguments
10351	INVALID_ARGUMENT_TYPE	Item ID specified must be a item (not a group or method)
10340	MINIMUM_VALUE_EXCEEDED	New item value is below the minimum
10341	MAXIMUM_VALUE_EXCEEDED	New items value is above the maximum
10500	DATA_SET_EMPTY	Data export operation returned no results.
10900	SENSOR_NOT_READY	Command specified requires sensor to be in the READY state.
10920	SENSOR_TYPE_NOT_ACTIVE	Command specified belongs to a different sensor type.
15000	VALUE_INVALID	Text value is invalid / unknown
15050	VALUE_INVALID	Text value is invalid - expecting True or False

Numeric ID	Text ID	Description
15100	STRING_TOO_LONG	String value specified exceeds maximum allowable length
20200	NO_AREAS_FOUND	Attempt to obtain value when no areas were found.
20600	NO_MATCHES_FOUND	Attempt to obtain value when no matches were found.
20800	NO_MATCHES_FOUND	Attempt to obtain value when no sort patterns were found.
80000	REMOTE_DISPLAY_NOT_CONNECTED	Remote Display must be connected to obtain this value
80001	REMOTE_DISPLAY_NOT_SUPPORTED	This sensor does not have Remote Display capability
80100	COMMAND_MODE_EXPECTED	The Trigger Mode must be set to "Command" perform this operation
80101	COMMAND_TIMED_OUT	The command timed out before finishing
80102	TRIGGER_REQUIRED	Access to the specified data requires a triggered inspection
80150	COMMAND_TIMED_OUT	The command timed out before finishing
80200	SYSTEM_ERROR_NOT_ACTIVE	The System Error must be active to execute this command
80300	TEACH_SENSOR_TYPE_INVALID	Teach requires Match Sensor type.
80350	MULTIPLE_INSPECTIONS_DISABLED	Requires multiple inspections to be enabled
80351	MULTIPLE_INSPECTIONS_EMPTY	No inspections are available in multiple inspection mode.
80400	PRODUCT_CHANGE_WHEN_NOT_READY	Sensor must be in the READY state to perform a product change.
80401	PRODUCT_CHANGE_INVALID_INSPECTION	Attempt to product change to a unknown or invalid inspection.
80402	PRODUCT_CHANGE_TIMEOUT	The Product Change operation timed out.
80403	PRODUCT_CHANGE_TO_SAME_INSPECTION	Attempt to product change to the same inspection.
80404	SENSOR_NAME_NOT_FOUND	Attempt to use a command without a sensor name in a multi-sensor inspection

7 Industrial Ethernet Overview

7.1 Device Setup

7.1.1 Set IP Address

When shipped, the device is assigned a default IP address - 192.168.0.1, a default Subnet Mask - 255.255.255.0, and a default gateway - 0.0.0.0. To change these defaults, click on Main Menu > System > Communications > Ethernet I/O.

7.1.2 Set Industrial Ethernet Protocol (EIP/Modbus/TCP/PCCC)

The Industrial Ethernet communication channel is disabled by default. In order to enable this channel, click on Main Menu > System > Communications > Industrial Ethernet > Connection. Select the channel of interest (EIP, Modbus/TCP or PCCC). Only one type of connection can be established at any given time.

Information about an established connection can be obtained from Main Menu > System > Communications > Industrial Ethernet > Status screen. Click on the connection of interest to view details.

This device provides extensive logging for the communication that occurs over the Industrial Ethernet connection. Logs can either be viewed from Main Menu > System > Communications > Industrial Ethernet > View Logs, or Main Menu > Logs > Communication Logs > Industrial Ethernet.

7.1.3 Set Trigger Mode

The sensor can be triggered using either the hardware trigger or through over the Industrial EtherNet. In order to only accept triggers generated through the Industrial EtherNet communication channel, click on the Main Menu > Imager > Trigger, and select Industrial EtherNet Only from the drop-down menu.

7.2 Supported Functions

The iVu Plus Series sensor is controlled over EtherNet/IP and Modbus/TCP using the input and output data it makes available as a slave device for those protocols.

Here are some of the Sensor operations that can be performed using input and output values:

- Product Change
- Teach Enable
- Trigger the sensor
- Read output indicators (pass/fail/ready/error)
- Read counters (pass, fail, system error, missed trigger, frame count, iteration count)
- Read iVu sensor results
- On Barcode, change compare string and its mask

7.2.1 iVu Input Values

The operation of the iVu Plus Series sensor can be controlled through input bits and commands.

Register/Input Coil Bits

The following commands can only be executed using bits:

Input Coil Bit	Command	Description
0	Product Change	Execute a product change (inspection number specified in the "Product Change Number" 32-bit integer register).
1	Teach Latch	Latch a teach flag. Teach is executed on next trigger.
2	Trigger	Causes system to trigger an inspection if ready.
3	Gated Trigger	Causes system to start looking for requested barcodes (BCR products only)
5	Set BCR String	Sets barcode compare string (BCR products only)
6	Set BCR Mask	Sets masks for barcode compare string (BCR products only)
15	Command	Set this bit to 1 to execute the command entered in the Command ID Register.

7.2.2 iVu Output Values

Using output values, the following information can be obtained:

- ACK bits (acknowledgement bits) for input commands, including error codes
- System indicators (Ready, Pass/Fail, Read/No Read, Output signals, Command Error, etc.)
- Inspection History (Iteration Count, Pass Count, Fail Count, etc.)
- Current Inspection Results (data of the sensor type contained in the inspection)
- Command Responses

Refer to the sections on protocols for more information.

ACK Flags

For each of the Command Flags there is a corresponding ACK flag. The Vision Sensor sets the ACK flag when the corresponding action is complete. Command flags cause actions to occur on the low-to-high transition of that flag. You must clear the command flag after the corresponding ACK flag has been observed to be high.

As an example, to use the Trigger ACK flag, the programming steps for triggering an inspection would be:

1. Wait for ready.
2. Set Trigger command flag to 1.
3. Wait for Trigger ACK to go to 1.
4. Set Trigger command flag to 0.

Command Responses

iVu Plus Series Command Channel commands executed using command IDs may have a response value. Depending on the Data Type, the response value will be contained in one or multiple registers. Refer to iVu Command Channel Commands section of this document and the iVu Plus Communication's Users Guide for more information about the iVu Command Channel.

7.3 Sensor Operation

Any Industrial Ethernet protocol can be used to trigger inspections, remote teach and perform command functions. On iVuPlus BCR models, compare strings can also be set.

7.3.1 General Command Execution

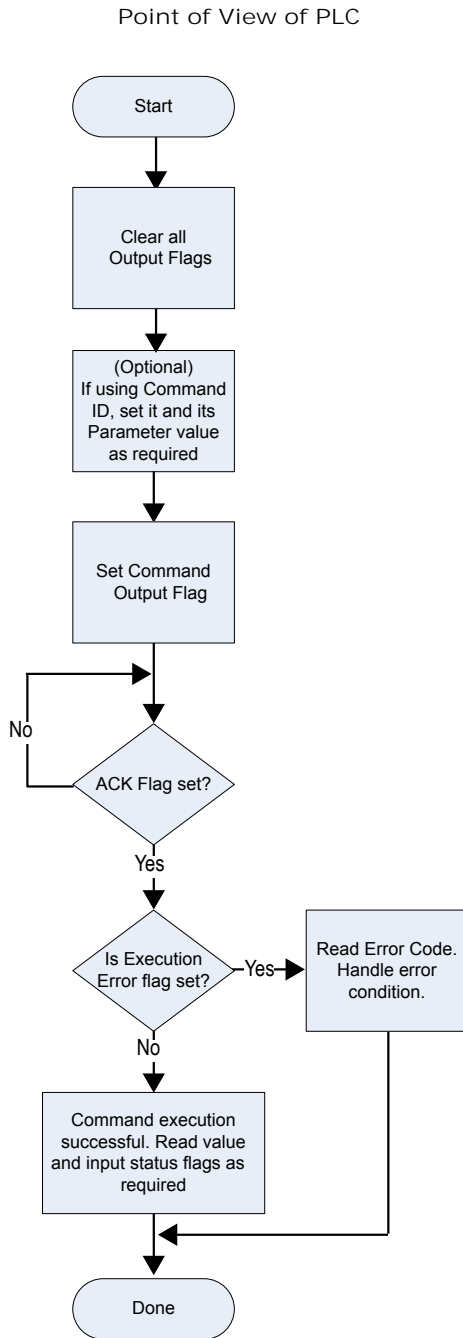

Following rules apply for the usage of input bit commands:

- Only one output bit can be set at a time.
- Corresponding ACK bits are only set high on completion of the command (if output bit is still high).
- Corresponding ACK bits are cleared when the output bit is cleared.
- When multiple output bits are set simultaneously, the Execution Error input bit is set and an Error Code value is reported on the input register.
- The Execution Error input bit is cleared when all ACK bits get cleared, or a new valid command is received.

7.4 EtherNet/IP

The iVu Plus device is controlled by a ControlLogix PLC using assembly objects. From the point-of-view of a PLC, there are three input assemblies and two output assemblies.

7.4.1 RSLogix5000 Configuration

To create an implicit Class 1 configuration to the iVu Plus using EIP when using a ControlLogix family PLC, configure the iVu Plus as a "Generic Ethernet Module" under the ENET_MODULE. The following is a sample setup of Banner sensor:

1. Add a generic Ethernet module to the PLC's Ethernet card.

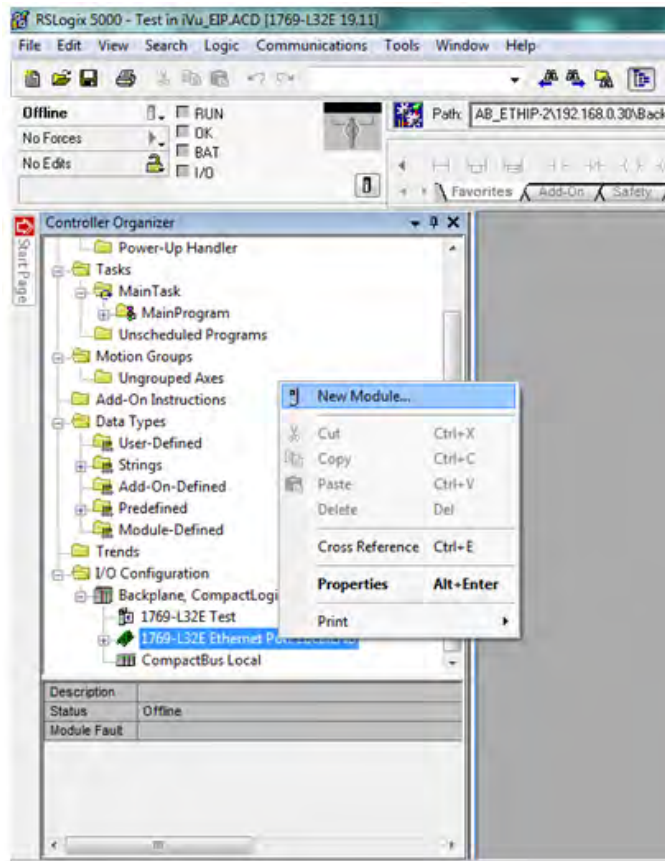

2. Select Module.

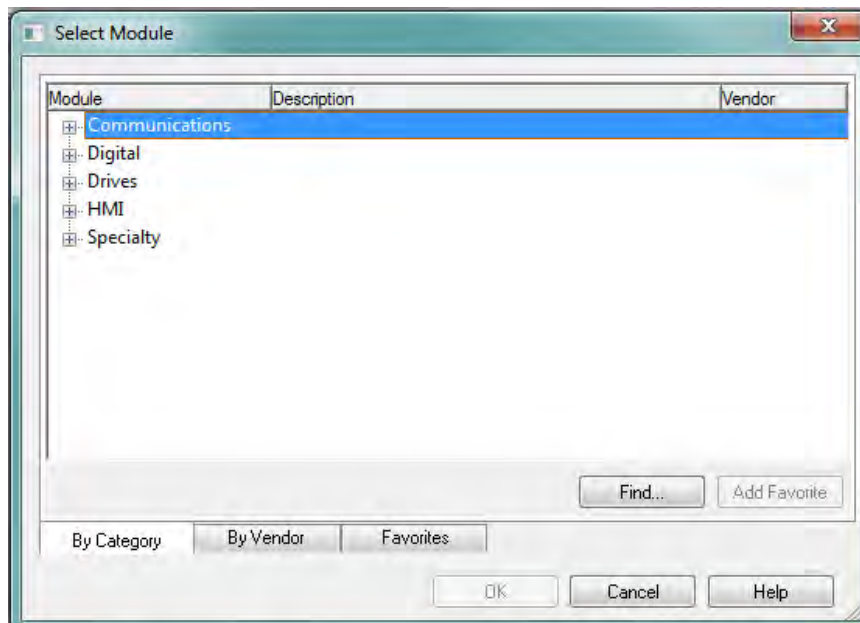

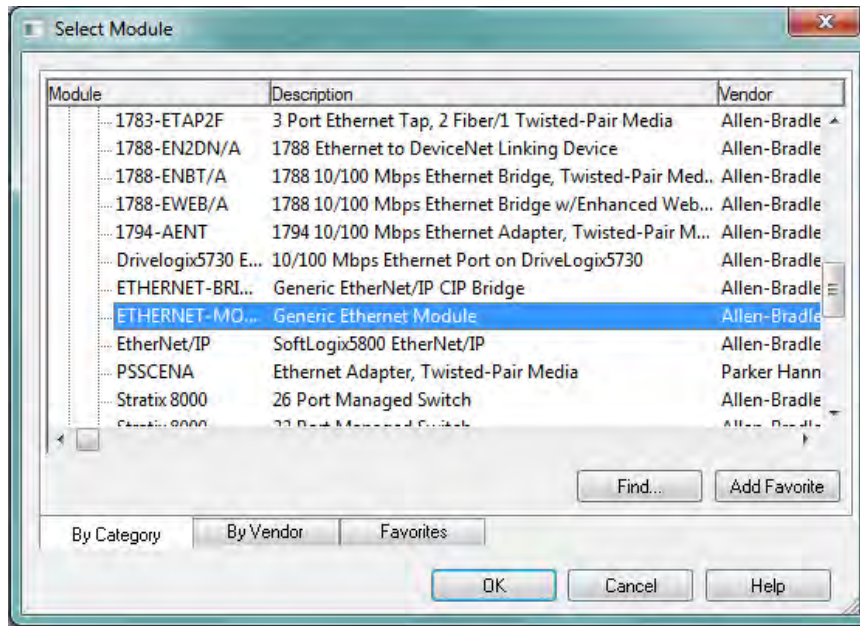

3. Configure Module Properties.



NOTE: The data type in the Comm Format must be changed to an INT.

See [Inputs to iVu \(Outputs from PLC\)](#) on page 106 and [Outputs from the iVu \(Inputs to the PLC\)](#) on page 107 for more information on each specific assembly instance.

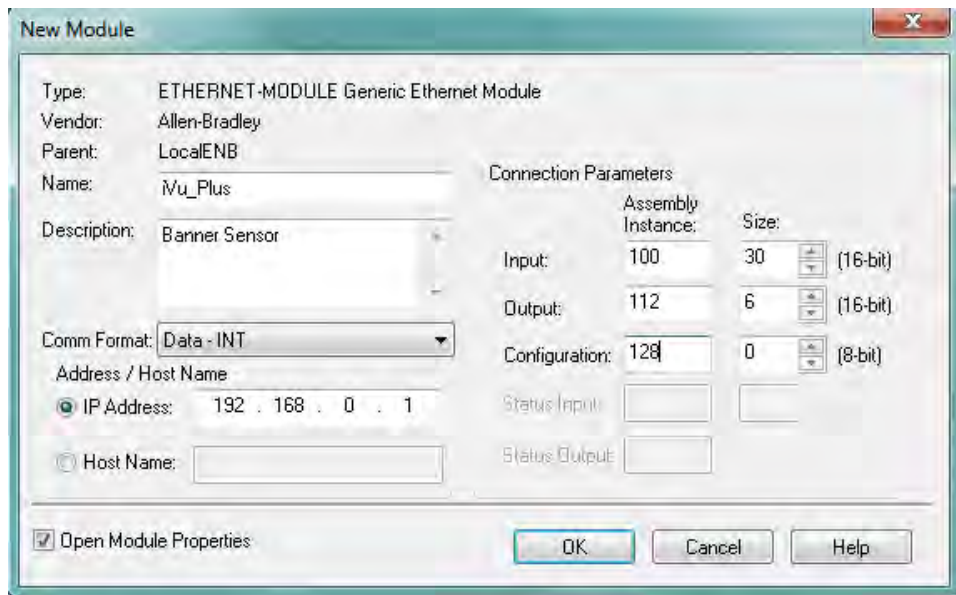

Figure 6. PLC Input Assembly (100), PLC Output Assembly (112)

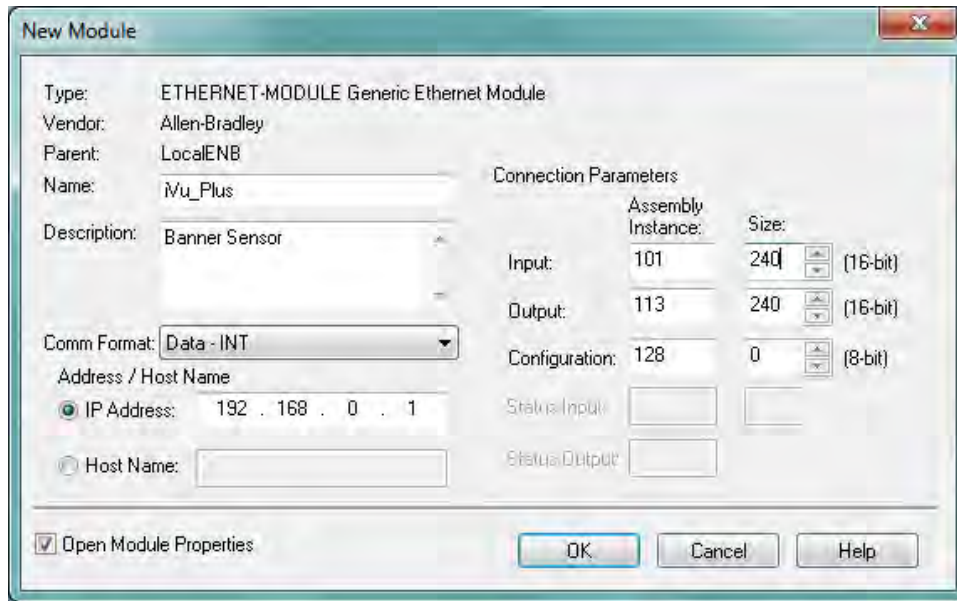

Figure 7. PLC Input Assembly (101), PLC Output Assembly (113)

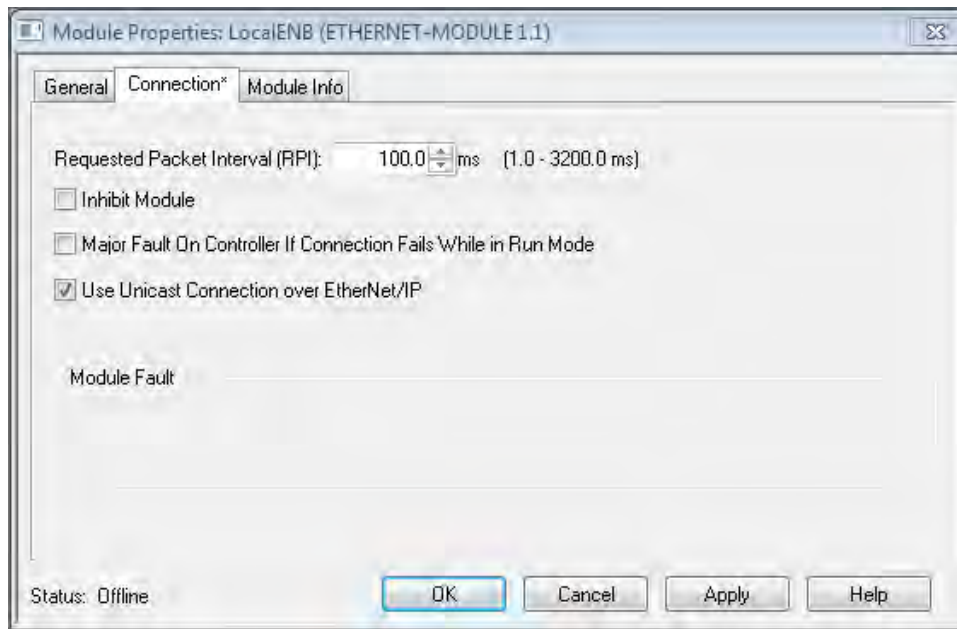
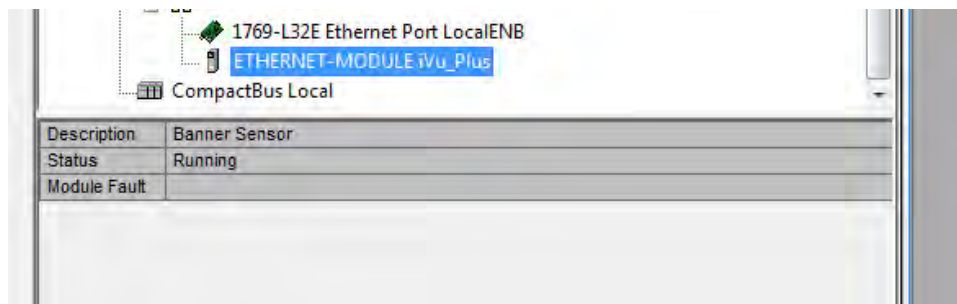

Figure 8. Select or deselect Unicast Connection as desired



NOTE: The minimum allowed RPI is 50 ms.

4. If the module configuration was successful, the following information should be displayed:



If the module configuration was not successful, the RSLogix 5000 software will indicate errors similar to the ones displayed below:

- ERROR: Assembly Instance number and/or size incorrect.

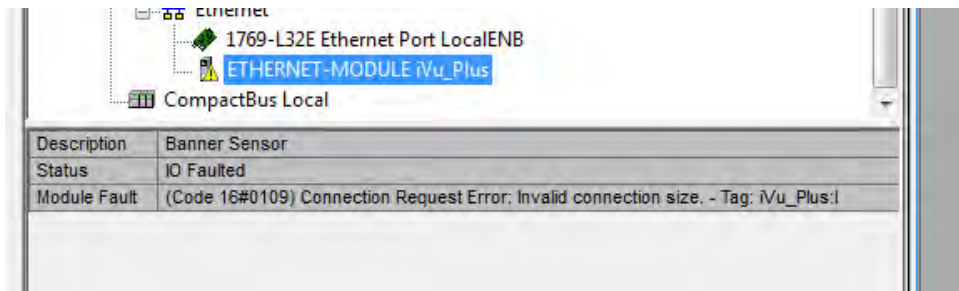

- ERROR: iVu Plus not powered up or EtherNet cable not attached.

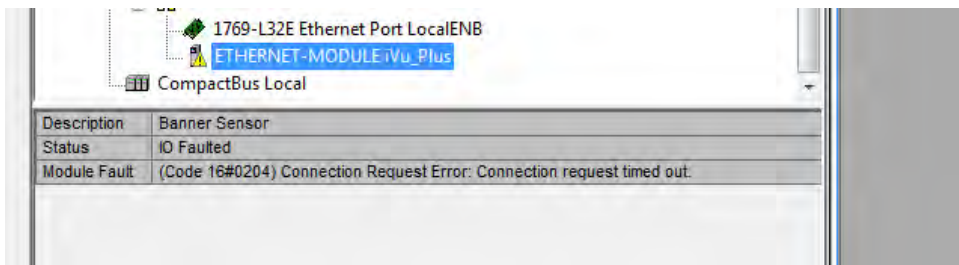

5. Locate the memory map setup from Banner module to PLC memory map.

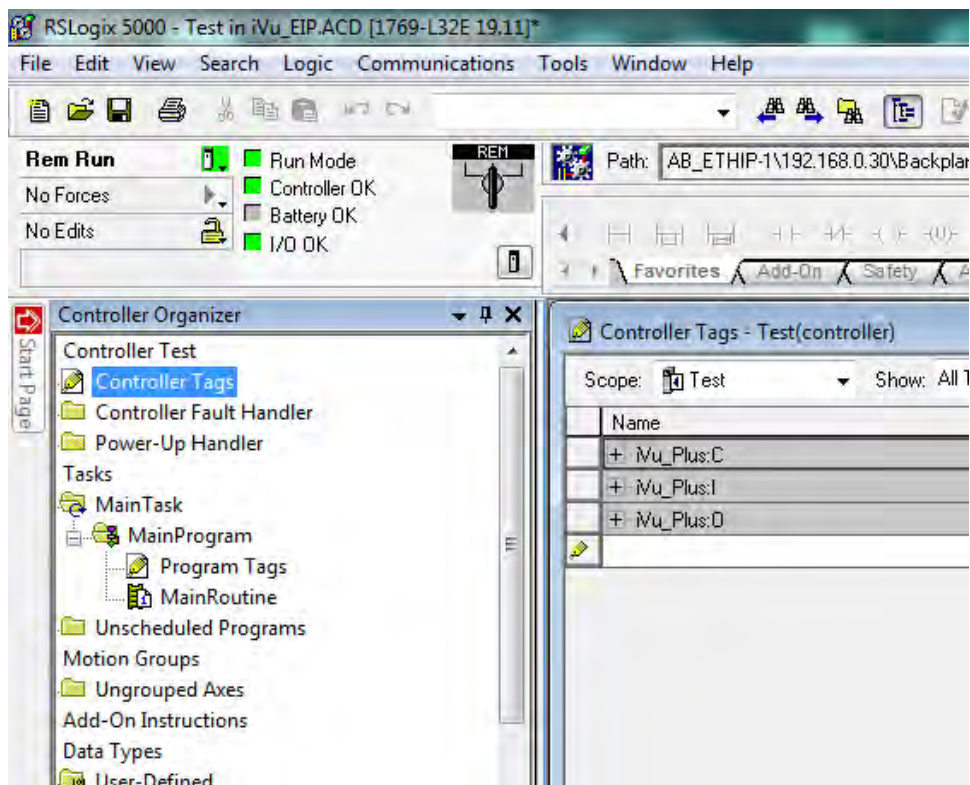

C = Configuration (not used)
 I = Inputs to PLC (outputs from iVu Plus)
 O = Outputs from PLC (inputs to iVu Plus)

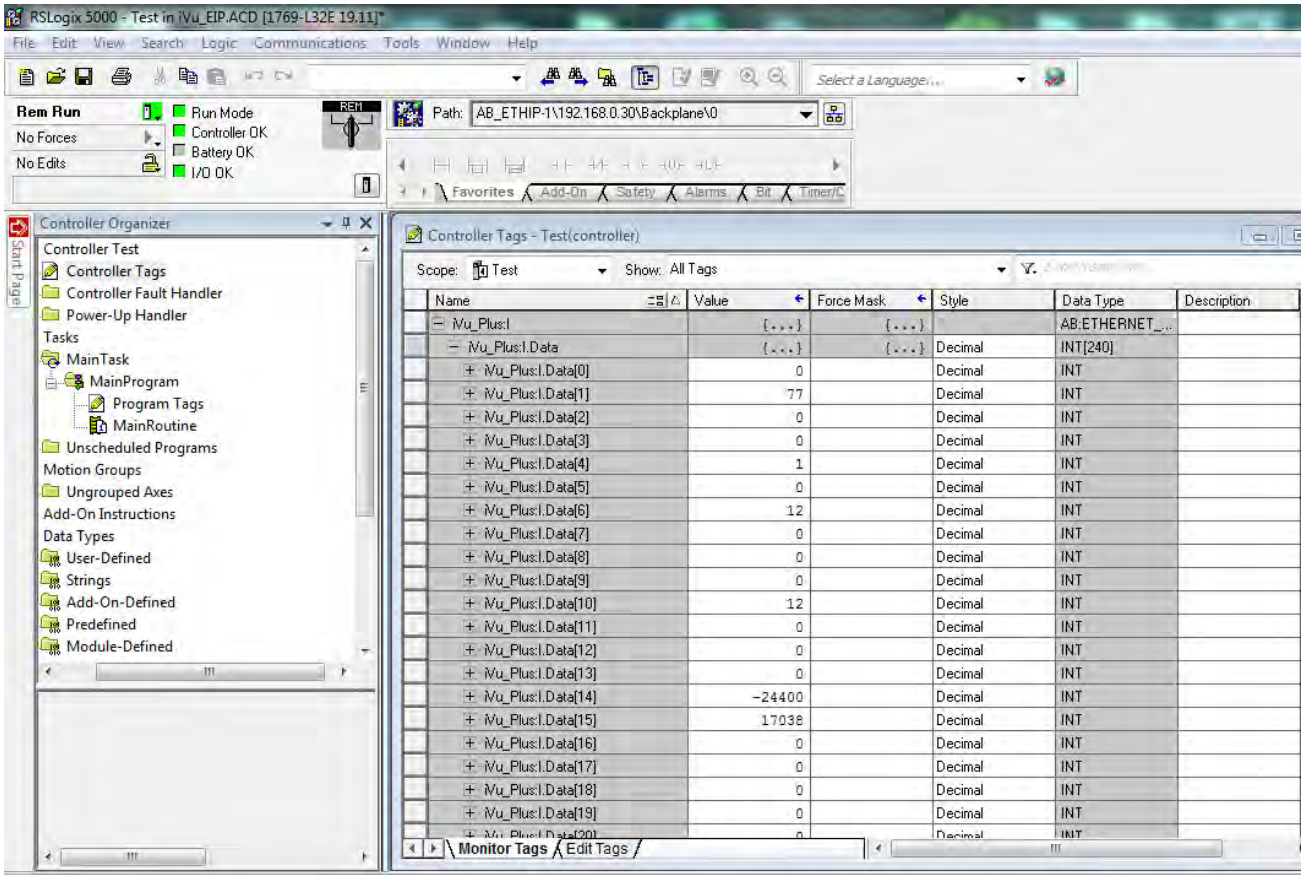

The iVu Plus memory map expanded. I = Inputs to PLC (outputs from iVu Plus).

Sample map demonstrating string values:

Name	Value	Force Mask	Style	Data Type	Description
+ iVu_Plus:I.Data[55]	1		Decimal	INT	
+ iVu_Plus:I.Data[56]	1		Decimal	INT	
+ iVu_Plus:I.Data[57]	1		Decimal	INT	
+ iVu_Plus:I.Data[58]	20		Decimal	INT	
+ iVu_Plus:I.Data[59]	20		Decimal	INT	
+ iVu_Plus:I.Data[60]	0		Decimal	INT	
+ iVu_Plus:I.Data[61]	22121		Decimal	INT	
+ iVu_Plus:I.Data[62]	20597		Decimal	INT	
+ iVu_Plus:I.Data[63]	30060		Decimal	INT	
+ iVu_Plus:I.Data[64]	8307		Decimal	INT	
+ iVu_Plus:I.Data[65]	27977		Decimal	INT	
+ iVu_Plus:I.Data[66]	26465		Decimal	INT	
+ iVu_Plus:I.Data[67]	8293		Decimal	INT	
+ iVu_Plus:I.Data[68]	25939		Decimal	INT	
+ iVu_Plus:I.Data[69]	29550		Decimal	INT	
+ iVu_Plus:I.Data[70]	29295		Decimal	INT	

Figure 9. Memory Map: Default



NOTE: ControlLogix string format. "iVu Plus Image Sensor"

+ iVu_Plus:I.Data[55]	1	Decimal	INT
+ iVu_Plus:I.Data[56]	1	Decimal	INT
+ iVu_Plus:I.Data[57]	1	Decimal	INT
+ iVu_Plus:I.Data[58]	20	Decimal	INT
+ iVu_Plus:I.Data[59]	20	Decimal	INT
+ iVu_Plus:I.Data[60]	0	Decimal	INT
+ iVu_Plus:I.Data[61]	'Vi'	ASCII	INT
+ iVu_Plus:I.Data[62]	'Pu'	ASCII	INT
+ iVu_Plus:I.Data[63]	'u1'	ASCII	INT
+ iVu_Plus:I.Data[64]	's'	ASCII	INT
+ iVu_Plus:I.Data[65]	'mI'	ASCII	INT
+ iVu_Plus:I.Data[66]	'ga'	ASCII	INT
+ iVu_Plus:I.Data[67]	'e'	ASCII	INT
+ iVu_Plus:I.Data[68]	'eS'	ASCII	INT
+ iVu_Plus:I.Data[69]	'sn'	ASCII	INT
+ iVu_Plus:I.Data[70]	'zo'	ASCII	INT

All data is initially transferred as "INT" data type. An ASCII string looks like gibberish in this format. Changing the "style" to ASCII instead of "Decimal" reveals the correct string data.

Figure 10. Memory Map: "Style" changed to ASCII

7.4.2 Inputs to iVu (Outputs from PLC)

PLC Assembly Instance 0x70 (112) - 6 Registers (iVu Inputs/PLC Outputs)

WORD #	WORD NAME	DATA TYPE
0	Input Bits Register (see Input and Output Flags Bits on page 115)	16-bit integer
1-2	Product Change Number	32-bit integer
3-5	<i>reserved</i>	

PLC Assembly Instance 0x71 (113) - 240 Registers (iVu Inputs/PLC Outputs)

WORD #	WORD NAME	DATA TYPE
0	Inputs Bit Register (see Input and Output Flags Bits on page 115)	16-bit integer
1-2	Product Change Number	32-bit integer
3-49	<i>reserved</i>	32-bit integer
50	Command ID	16-bit integer
51	Command Parameter Int16	16-bit integer
52-53	Command Parameter Int32	32-bit integer
54-55	Command Parameter Float	Float
56-57	String Length	32-bit integer
58-107	String Parameter	100 Byte Array
108	<i>reserved</i>	16-bit integer
109-110	Barcode String/Mask Length	32-bit integer
111-210	Barcode String/Mask	200 Byte Array
211-239	<i>reserved</i>	

7.4.3 Outputs from the iVu (Inputs to the PLC)

PLC Assembly Instance 0x64 (100) - 30 Registers (iVu Outputs/PLC Inputs)

WORD #	WORD NAME	DATA TYPE
0	Input Bits ACK Register (see Input and Output Flags Bits on page 115)	16-bit integer
1	Output Bits Register (see Input and Output Flags Bits on page 115)	16-bit integer
2-3	Error Code	32-bit integer
4-5	Inspection Number	32-bit integer
6-7	Iteration Count	32-bit integer
8-9	Pass Count	32-bit integer
10-11	Fail Count	32-bit integer
12-13	Missed Triggers	32-bit integer
14-15	Current Inspection Time	Float
16	Sensor P/F Coil	
17-29	<i>reserved</i>	

PLC Assembly Instance 0x65 (101) - 240 Registers (iVu Outputs/PLC Inputs)

Table 9: Sensor Type - Area (iVu Plus TG)

WORD #	WORD NAME	DATA TYPE
0	Input Bits ACK Register (see Input and Output Flags Bits on page 115)	16-bit integer
1	Output Bits Register (see Input and Output Flags Bits on page 115)	16-bit integer
2-3	Error Code	32-bit integer
4-5	Inspection Number	32-bit integer
6-7	Iteration Count	32-bit integer
8-9	Pass Count	32-bit integer
10-11	Fail Count	32-bit integer
12-13	Missed Triggers	32-bit integer
14-15	Current Inspection Time	Float
16	Sensor Pass/Fail Coil	
17-29	<i>reserved</i>	
30-52	Inspection Name	2-Word Length + 20-unicode chars
53-54	Frame Number	32-bit integer
55	Sensor Type ID	16-bit integer
56-57	Area Count	32-bit integer
58-59	Area Range Min	32-bit integer
60-61	Area Range Max	32-bit integer
62-170	<i>reserved</i>	
171	Command Status	16-bit integer
172	Command Response Int16	16-bit integer
173-174	Command Response Int32	32-bit integer
175-176	Command Response Float	Float
177-178	Command Response Length	32-bit integer
179-228	Command Response Data	100 Byte Array
229-239	<i>reserved</i>	

Table 10: Sensor Type - Blemish (iVu Plus TG)

WORD #	WORD NAME	DATA TYPE
0	Input Bits ACK Register (see Input and Output Flags Bits on page 115)	16-bit integer
1	Output Bits Register (see Input and Output Flags Bits on page 115)	16-bit integer
2-3	Error Code	32-bit integer
4-5	Inspection Number	32-bit integer
6-7	Iteration Count	32-bit integer
8-9	Pass Count	32-bit integer
10-11	Fail Count	32-bit integer
12-13	Missed Triggers	32-bit integer
14-15	Current Inspection Time	Float
16	Sensor Pass/Fail Coil	
17-29	<i>reserved</i>	
30-52	Inspection Name	2-Word Length + 20-unicode chars
53-54	Frame Number	32-bit integer
55	Sensor Type ID	16-bit integer
56-57	Blemish Count	32-bit integer
58-59	Blemish Min Edge Length	32-bit integer
60-61	Blemish Max Edge Length	32-bit integer
62-170	<i>reserved</i>	
171	Command Status	16-bit integer
172	Command Response Int16	16-bit integer
173-174	Command Response Int32	32-bit integer
175-176	Command Response Float	Float
177-178	Command Response Length	32-bit integer
179-228	Command Response Data	100 Byte Array
229-239	<i>reserved</i>	

Table 11: Sensor Type - Match (iVu Plus TG)

WORD #	WORD NAME	DATA TYPE
0	Input Bits ACK Register (see Input and Output Flags Bits on page 115)	16-bit integer
1	Output Bits Register (see Input and Output Flags Bits on page 115)	16-bit integer
2-3	Error Code	32-bit integer
4-5	Inspection Number	32-bit integer
6-7	Iteration Count	32-bit integer
8-9	Pass Count	32-bit integer
10-11	Fail Count	32-bit integer
12-13	Missed Triggers	32-bit integer
14-15	Current Inspection Time	Float
16	Sensor Pass/Fail Coil	
17-29	<i>reserved</i>	
30-52	Inspection Name	2-Word Length + 20-unicode chars
53-54	Frame Number	32-bit integer
55	Sensor Type ID	16-bit integer
56-57	Match Count	32-bit integer
58	Match Min Percent Match	16-bit integer
59	Match Max Percent Match	16-bit integer
60-170	<i>reserved</i>	
171	Command Status	16-bit integer
172	Command Response Int16	16-bit integer
173-174	Command Response Int32	32-bit integer
175-176	Command Response Float	Float
177-178	Command Response Length	32-bit integer
179-228	Command Response Data	100 Byte Array
229-239	<i>reserved</i>	

Table 12: Sensor Type - Sort (iVu Plus TG)

WORD #	WORD NAME	DATA TYPE
0	Input Bits ACK Register (see Input and Output Flags Bits on page 115)	16-bit integer
1	Output Bits Register (see Input and Output Flags Bits on page 115)	16-bit integer
2-3	Error Code	32-bit integer
4-5	Inspection Number	32-bit integer
6-7	Iteration Count	32-bit integer
8-9	Pass Count	32-bit integer
10-11	Fail Count	32-bit integer
12-13	Missed Triggers	32-bit integer
14-15	Current Inspection Time	Float
16	Sensor Pass/Fail Coil	
17-29	<i>reserved</i>	
30-52	Inspection Name	2-Word Length + 20-unicode chars
53-54	Frame Number	32-bit integer
55	Sensor Type ID	16-bit integer
56	Sort Pattern Map	16-bit integer
57	Sort Pattern Count	16-bit integer
58	Sort Pattern 1 Count	16-bit integer
59	Sort Pattern 2 Count	16-bit integer
60	Sort Pattern 3 Count	16-bit integer
61	Sort Pattern 4 Count	16-bit integer
62	Sort Pattern 5 Count	16-bit integer
63	Sort Pattern 6 Count	16-bit integer
64	Sort Pattern 7 Count	16-bit integer
65	Sort Pattern 8 Count	16-bit integer
66	Sort Pattern 9 Count	16-bit integer
67	Sort Pattern 10 Count	16-bit integer
68	Sort Min Percent Match	16-bit integer
69	Sort Max Percent Match	16-bit integer
70-170	<i>reserved</i>	
171	Command Status	16-bit integer
172	Command Response Int16	16-bit integer
173-174	Command Response Int32	32-bit integer
175-176	Command Response Float	Float
177-178	Command Response Length	32-bit integer
179-228	Command Response Data	100 Byte Array
229-239	<i>reserved</i>	

7.4.4 Multiple Sensors Mapping Options

When using an iVu Plus TG with multiple sensors in an inspection, there are two mapping options: Default and Custom.

Default Map

Main Menu > System > Communications > Industrial EtherNet > Map > Default

Automatically maps sensor data for each inspection. Recommended when execution order of sensor types is the same across inspections. When inspection has multiple sensors, the first 5 sensor results will be shown starting at offset 55. Each sensor result will occupy 20 words.

The following is a table of EIP assembly 0x65 when using Default Map setting.

WORD #	WORD NAME	Data Type
0	Input Bits ACK Register	16-bit integer
1	Output Bits Register	16-bit integer
2-3	Error Code	32-bit integer
4-5	Inspection Number	32-bit integer
6-7	Iteration Count	32-bit integer
8-9	Pass Count	32-bit integer
10-11	Fail Count	32-bit integer
12-13	Missed Triggers	32-bit integer
14-15	Current Inspection Time	Float
16	Sensor Pass/Fail Coil	16-bit integer
17-29	reserved	
30-52	Inspection Name	2-Word Length + 20-Unicode chars
53-54	Frame Number	32-bit integer
55	Sensor Type ID (Sensor 1)	16-bit integer
56-74	Sensor 1 Specific Data	16-bit integer
75	Sensor Type ID (Sensor 2)	16-bit integer
76-89	Sensor 2 Specific Data	16-bit integer
95	Sensor Type ID (Sensor 3)	16-bit integer
95-114	Sensor 3 Specific Data	16-bit integer
115	Sensor Type ID (Sensor 4)	16-bit integer
116-134	Sensor 4 Specific Data	16-bit integer
135	Sensor Type ID (Sensor 5)	16-bit integer
136-154	Sensor 5 Specific Data	16-bit integer
155-170	reserved	
171	Command Status	16-bit integer
172	Command Response Int16	16-bit integer
173-174	Command Response Int32	32-bit integer
175-176	Command Response Float	Float
177-178	Command Response Length	32-bit integer
179-228	Command Response Data	100 Byte Array
229-239	reserved	

If the inspection contains more than 5 sensors, the sensor(s) after the 5th one will not be on the map.

Table 13: Area Sensor Type ID = 2

Sensor Specific Data	Data Size
Area Count	32- bit integer
Area Range Min	32- bit integer
Area Range Max	32- bit integer

Table 14: Blemish Sensor Type ID = 3

Sensor Specific Data	Sensor Location
Blemish Count	32- bit integer
Blemish Min Edge Length	32- bit integer
Blemish Min Edge Length	32- bit integer

Table 15: Match Sensor Type ID = 4

Sensor Specific Data	Sensor Location
Match Count	32- bit integer
Match Min Percent	16- bit integer
Match Max Percent	16- bit integer

Table 16: Sort Sensor Type ID = 5

Sensor Specific Data	Sensor Location
Sort Pattern Map	16-bit integer
Sort Pattern Count	16-bit integer
Sort Pattern 1 Count	16-bit integer
Sort Pattern 2 Count	16-bit integer
Sort Pattern 3 Count	16-bit integer
Sort Pattern 4 Count	16-bit integer
Sort Pattern 5 Count	16-bit integer
Sort Pattern 6 Count	16-bit integer
Sort Pattern 7 Count	16-bit integer
Sort Pattern 8 Count	16-bit integer
Sort Pattern 9 Count	16-bit integer
Sort Pattern 10 Count	16-bit integer
Sort Min Percent Match	16-bit integer
Sort Max Percent Match	16-bit integer

Custom Map

Main Menu > System > Communications > Industrial EtherNet > Map > Custom

Allows customization of fix sensor data on the map. Select data items of interest for each sensor type. Recommended when execution order of sensor types vary across inspections or when using more than 5 sensors.

A System level custom map is supported for additional flexibility. When Custom Map is selected, a customizable space is used in the offset range (55 to 166) on EIP assembly 0x65 registers.

The following is a table of EIP assembly 0x65 registers when using Custom Map setting.

WORD #	WORD NAME	Data Type
0	Input Bits ACK Register	16-bit integer
1	Output Bits Register	16-bit integer
2-3	Error Code	32-bit integer
4-5	Inspection Number	32-bit integer
6-7	Iteration Count	32-bit integer
8-9	Pass Count	32-bit integer
10-11	Fail Count	32-bit integer
12-13	Missed Triggers	32-bit integer
14-15	Current Inspection Time	Float
16	Sensor Pass/Fail Coil	16-bit integer
17-29	<i>reserved</i>	
30-52	Inspection Name	2-Word Length + 20-unicode chars
53-54	Frame Number	32-bit integer
55-166	Customizable Space (112 reg)	
167-170	<i>reserved</i>	
171	Command Status	16-bit integer
172	Command Response Int16	16-bit integer
173-174	Command Response Int32	32-bit integer
175-176	Command Response Float	Float
177-178	Command Response Length	32-bit integer
179-228	Command Response Data	100 Byte Array
229-239	<i>reserved</i>	

Configure Custom Map

Enable Custom Map by selecting Custom on the drop down list.



Click on the yellow arrow button to Custom IE Map screen. Custom IE Map screen allows choosing sensor result data that will appear on the customizable space.



The bottom of the screen shows the word usage on the customizable space. In the screenshot above, seven words have been used for one Area sensor "Area (1)". Use the yellow arrow button next to the Area sensor row to go to the "Area Sensor Data" in the following graphic.



On the "Area Sensor Data" screen above, "Area Count", "Area Range Min" and "Area Range Max" are available to add into the customizable space. The number to the right of each item shows how many words are required to display the data. The bottom reservation count shows the number of Area Sensors that will be reserved on the customizable space.

Since only one Area Sensor's worth of data is reserved on the screenshot above, the selected data will be collected from the first Area sensor in the current inspection. When multiple Area Sensors have been reserved, the data will be arranged in the sequential manner of the sensor type in the current inspection.

Use the green arrow icon (Back) button to go back to the custom map summary screen.



User may continue to add more data from any sensor type as required or reserve more sensors into the customizable space.

"Sensor Name" and "Sensor Type ID" are global settings that are part of any individual sensor reservation. When they are checked, they will be inserted into each sensor reservation.

Here is an example of multiple sensors inspection and its output location on the customizable space.

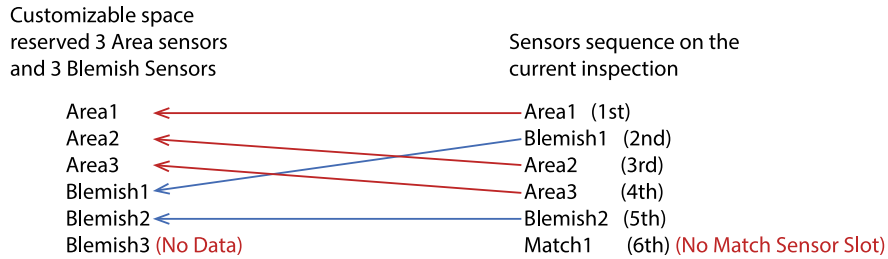

There are only 2 Blemish sensors on the current inspection; Blemish3 location will be all zero on the customizable space. The customizable space had not reserved a Match sensor, Match1 from the inspection will not be outputted on the customizable space.

7.4.5 Input and Output Flags Bits

Inputs Bits Register (Command Flag Bits)

Bit Position

15	14	13	12	11	10	9	8	7	6	5	4	3	2	1	0
Command									Set BCR Mask	Set BCR String		Gated Trigger	Trigger	Teach Latch	Product Change

Input Bits ACK Register (ACK Flag Bits)

Bit Position

15	14	13	12	11	10	9	8	7	6	5	4	3	2	1	0
Command ACK									Set BCR Mask ACK	Set BCR String ACK		Gated Trigger ACK	Trigger ACK	Teach Latch ACK	Product Change ACK

Output Bits Register (iVu Status Flag Bits)

Bit Position

15	14	13	12	11	10	9	8	7	6	5	4	3	2	1	0
Execution Error	System Error	Teach Error	Missed Trigger					Output 3	Output 2	Output 1		Ready Latch	Read/No Read	Pass/Fail	Ready

7.4.6 Configuration Assembly Object

The iVuPlus EIP implementation does not support an assembly object configuration instance. However, one is required for creation of implicit Class 1 connections on a ControlLogix family PLC. Therefore, a configuration instance is defined as instance number 0x80 (128 decimal). Its size is zero.

7.4.7 Data Formats

The iVuPlus EIP implementation supports 32-bit Integers in LSW_MSW data format. The least significant word is stored first, then the most significant word. This format is used for Allen-Bradley ControlLogix PLCs.

The string format is compatible with the Allen-Bradley ControlLogix built-in string data type. This format is a 32 bit (DINT) length followed by character bytes (SINT). This results in the following string format as viewed from the iVu Plus:

Word	0	1	2		3		4			
	Length LSW	Length MSW	byte 1	byte 0	byte 3	byte 2	byte 5	byte 4

7.4.8 Minimum Requested Packet Interval (RPI) Value

iVuPlus devices can operate with input and output Requested Packet Intervals (RPIs) as low as 50 milliseconds. The device may not operate reliably if a lower RPI value is selected.

7.5 Modbus/TCP

The Modbus/TCP protocol provides device control using register and coil banks defined by the slave device. This section defines the iVu Plus Modbus/TCP register and coil banks. From the point of view of the slave device (PLC), there is one output coil registers and two Input Coil registers. The bits in the Output Coil Registers cause actions to occur. The corresponding ACK bits in the Input Coil register get set when the action is complete. The Status Coil register provides status of certain system states. By specification, Modbus/TCP uses TCP port 502.

Note that the output coils correspond to the Output and ACK Flags, and the input coils correspond to the Input Flags.

Modbus Function Codes Supported:

- 01: Read Coil Status
- 02: Read Input Status
- 03: Read Holding Registers
- 04: Read Input Registers
- 05: Force Single Coil
- 06: Preset Single Register
- 07: Read Exception Status
- 15: Write Multiple Coils
- 16: Preset Multiple Registers

7.5.1 Holding Registers

The Holding registers are used by the PLC to push values to the iVu Plus sensor. These values are accessed in the register address range of 40001 - 40240. To write, use Function Codes 6/16 (Preset Single/Multiple Registers). Also available in this range of registers are the registers containing output data. These outputs are available using the address range of 41001 - 41480. To read these output into the PLC use Function Code 03 (Read Holding Registers).

Table 17: Modbus/TCP iVu Input Registers Map

REGISTER	WORD NAME	DATA TYPE
40001	Input Coil Bits (see Input and Output Coils on page 126)	16-bit integer
40002-3	Product Change Number	32-bit integer
40004-50	<i>reserved</i>	32-bit integer
40051	Command ID	16-bit integer
40052	Command Parameter Int16	16-bit integer
40053-54	Command Parameter Int 32	32-bit integer
40055-56	Command Parameter	Float
40057-58	Command Parameter String Length	32-bit integer
40059-108	Command Parameter String	100 Byte Array
40109	<i>reserved</i>	16-bit integer
40110-111	BCR String/Mask Length	32-bit integer
40112-211	BCR String/Mask	200 Byte Array
40212-240	<i>reserved</i>	

7.5.2 Output Registers

The Output registers are used to send output values from the iVu Plus to the PLC. Note that some devices (such as Modicon family PLCs) cannot access data using the 30000 range of register addresses. For these devices, the output values are also available using the 40000 range of addresses (at offset 41000). To access the Modbus/TCP Output Registers use Function Code 04 (Read Input Registers).

Output Registers Map

Table 18: Sensor Type - Area (iVu Plus TG)

REGISTER	WORD NAME	DATA TYPE
30001	Input Coil ACK Bits (see Input and Output Coils on page 126)	16-bit integer
30002	Status Coil Bits (see Input and Output Coils on page 126)	16-bit integer
30003-4	Error Code	32-bit integer
30005-6	Inspection Number	32-bit integer
30007-8	Iteration Count	32-bit integer
30009-10	Pass Count	32-bit integer
30011-12	Fail Count	32-bit integer
30013-14	Missed Triggers	32-bit integer
30015-16	Current Inspection Time	Float
30017	Sensor Pass/Fail Coil	
30018-30	<i>reserved</i>	
30031-53	Inspection Name	2-Word Length + 20-unicode chars
30054-55	Frame Number	32-bit integer
30056	Sensor Type ID	16-bit integer
30057-58	Area Count	32-bit integer
30059-60	Area Range Min	32-bit integer
30061-62	Area Range Max	32-bit integer
30063-171	<i>reserved</i>	
30172	Command Status	16-bit integer
30173	Command Response Int16	16-bit integer
30174-75	Command Response Int32	32-bit integer
30176-77	Command Response	Float
30178-79	Command Response Length	16-bit integer
30180-229	Command Response Data	100 Byte Array
30230-240	<i>reserved</i>	

Table 19: Sensor Type - Blemish (iVu Plus TG)

REGISTER	WORD NAME	DATA TYPE
30001	Input Coil ACK Bits (see Input and Output Coils on page 126)	16-bit integer
30002	Status Coil Bits (see Input and Output Coils on page 126)	16-bit integer
30003-4	Error Code	32-bit integer
30005-6	Inspection Number	32-bit integer
30007-8	Iteration Count	32-bit integer
30009-10	Pass Count	32-bit integer
30011-12	Fail Count	32-bit integer
30013-14	Missed Triggers	32-bit integer
30015-16	Current Inspection Time	Float
30017	Sensor Pass/Fail Coil	
30018-30	<i>reserved</i>	
30031-53	Inspection Name	2-Word Length + 20-unicode chars
30054-55	Frame Number	32-bit integer
30056	Sensor Type ID	16-bit integer
30057-58	Blemish Count	32-bit integer
30059-60	Blemish Min Edge Length	32-bit integer
30061-62	Blemish Max Edge Length	32-bit integer
30063-171	<i>reserved</i>	
30172	Command Status	16-bit integer
30173	Command Response Int16	16-bit integer
30174-75	Command Response Int32	32-bit integer
30176-77	Command Response	Float
30178-79	Command Response Length	32-bit integer
30180-229	Command Response Data	100 Byte Array
30230-240	<i>reserved</i>	

Table 20: Sensor Type - Match (iVu Plus TG)

REGISTER	WORD NAME	DATA TYPE
30001	Input Coil ACK Bits (see Input and Output Coils on page 126)	16-bit integer
30002	Status Coil Bits (see Input and Output Coils on page 126)	16-bit integer
30003-4	Error Code	32-bit integer
30005-6	Inspection Number	32-bit integer
30007-8	Iteration Count	32-bit integer
30009-10	Pass Count	32-bit integer
30011-12	Fail Count	32-bit integer
30013-14	Missed Triggers	32-bit integer
30015-16	Current Inspection Time	Float
30017	Sensor Pass/Fail Coil	
30018-30	<i>reserved</i>	
30031-53	Inspection Name	2-Word Length + 20-unicode chars
30054-55	Frame Number	32-bit integer
30056	Sensor Type ID	16-bit integer
30057-58	Match Count	32-bit integer
30059	Match Min Percent Match	16-bit integer
30060	Match Max Percent Match	16-bit integer
30061-171	<i>reserved</i>	
30172	Command Status	16-bit integer
30173	Command Response Int16	16-bit integer
30174-75	Command Response Int32	32-bit integer
30176-77	Command Response	Float
30178-79	Command Response Length	32-bit integer
30180-229	Command Response Data	100 Byte Array
30230-240	<i>reserved</i>	

Table 21: Sensor Type - Sort (iVu Plus TG)

REGISTER	WORD NAME	DATA TYPE
30001	Input Coil ACK Bits (see Input and Output Coils on page 126)	16-bit integer
30002	Status Coil Bits (see Input and Output Coils on page 126)	16-bit integer
30003-4	Error Code	32-bit integer
30005-6	Inspection Number	32-bit integer
30007-8	Iteration Count	32-bit integer
30009-10	Pass Count	32-bit integer
30011-12	Fail Count	32-bit integer
30013-14	Missed Triggers	32-bit integer
30015-16	Current Inspection Time	Float
30017	Sensor Pass/Fail Coil	
30018-30	<i>reserved</i>	
30031-53	Inspection Name	2-Word Length + 20-unicode chars
30054-55	Frame Number	32-bit integer
30056	Sensor Type ID	16-bit integer
30057	Sort Pattern Map	16-bit integer
30058	Sort Pattern Count	16-bit integer
30059	Sort Pattern 1 Count	16-bit integer
30060	Sort Pattern 2 Count	16-bit integer
30061	Sort Pattern 3 Count	16-bit integer
30062	Sort Pattern 4 Count	16-bit integer
30063	Sort Pattern 5 Count	16-bit integer
30064	Sort Pattern 6 Count	16-bit integer
30065	Sort Pattern 7 Count	16-bit integer
30066	Sort Pattern 8 Count	16-bit integer
30067	Sort Pattern 9 Count	16-bit integer
30068	Sort Pattern 10 Count	16-bit integer
30069	Sort Min Percent Match	16-bit integer
30070	Sort Max Percent Match	16-bit integer
30071-171	<i>reserved</i>	
30172	Command Status	16-bit integer
30173	Command Response Int16	16-bit integer
30174-75	Command Response Int32	32-bit integer
30176-77	Command Response	Float
30178-79	Command Response Length	32-bit integer

REGISTER	WORD NAME	DATA TYPE
30180-229	Command Response Data	100 Byte Array
30230-240	<i>reserved</i>	

7.5.3 Multiple Sensors Mapping Options

When using an iVu Plus TG with multiple sensors in an inspection, there are two mapping options: Default and Custom.

Default Map

Main Menu > System > Communications > Industrial EtherNet > Map > Default

Automatically maps sensor data for each inspection. Recommended when execution order of sensor types is the same across inspections. When inspection has multiple sensors, the first 5 sensor results will be shown starting at offset 55. Each sensor result will occupy 20 words.

The following is a table of MODBUS/TCP registers at 30001 - 30240 when using Default Map setting.

WORD #	WORD NAME	Data Type
30001	Input Coil ACK Bits	16-bit integer
30002	Status Coil Bits	16-bit integer
30003-4	Error Code	32-bit integer
30005-6	Inspection Number	32-bit integer
30007-8	Iteration Count	32-bit integer
30009-10	Pass Count	32-bit integer
30011-12	Fail Count	32-bit integer
30013-14	Missed Triggers	32-bit integer
30015-16	Current Inspection Time	Float
30017	Sensor Pass/Fail Coil	16-bit integer
30018-30	<i>reserved</i>	
30031-53	Inspection Name	2-Word Length + 20-Unicode chars
30054-55	Frame Number	32-bit integer
30056	Sensor Type ID (Sensor 1)	16-bit integer
30057-30075	Sensor 1 Specific Data	16-bit integer
30076	Sensor Type ID (Sensor 2)	16-bit integer
30077-90	Sensor 2 Specific Data	16-bit integer
30096	Sensor Type ID (Sensor 3)	16-bit integer
30097-30115	Sensor 3 Specific Data	16-bit integer
30116	Sensor Type ID (Sensor 4)	16-bit integer
30117-135	Sensor 4 Specific Data	16-bit integer
30136	Sensor Type ID (Sensor 5)	16-bit integer
30137-155	Sensor 5 Specific Data	16-bit integer
30156-171	<i>reserved</i>	
30172	Command Status	16-bit integer
30173	Command Response Int16	16-bit integer
30174-175	Command Response Int32	32-bit integer
30176-177	Command Response Float	Float
30178-179	Command Response Length	32-bit integer
30180-229	Command Response Data	100 Byte Array

WORD #	WORD NAME	Data Type
30230-240	reserved	

If the inspection contains more than 5 sensors, the sensor(s) after the 5th one will not be on the map.

Table 22: Area Sensor Type ID = 2

Sensor Specific Data	Data Size
Area Count	32- bit integer
Area Range Min	32- bit integer
Area Range Max	32- bit integer

Table 23: Blemish Sensor Type ID = 3

Sensor Specific Data	Sensor Location
Blemish Count	32- bit integer
Blemish Min Edge Length	32- bit integer
Blemish Min Edge Length	32- bit integer

Table 24: Match Sensor Type ID = 4

Sensor Specific Data	Sensor Location
Match Count	32- bit integer
Match Min Percent	16- bit integer
Match Max Percent	16- bit integer

Table 25: Sort Sensor Type ID = 5

Sensor Specific Data	Sensor Location
Sort Pattern Map	16-bit integer
Sort Pattern Count	16-bit integer
Sort Pattern 1 Count	16-bit integer
Sort Pattern 2 Count	16-bit integer
Sort Pattern 3 Count	16-bit integer
Sort Pattern 4 Count	16-bit integer
Sort Pattern 5 Count	16-bit integer
Sort Pattern 6 Count	16-bit integer
Sort Pattern 7 Count	16-bit integer
Sort Pattern 8 Count	16-bit integer
Sort Pattern 9 Count	16-bit integer
Sort Pattern 10 Count	16-bit integer
Sort Min Percent Match	16-bit integer
Sort Max Percent Match	16-bit integer

Custom Map

Main Menu > System > Communications > Industrial EtherNet > Map > Custom

Allows customization of fix sensor data on the map. Select data items of interest for each sensor type. Recommended when execution order of sensor types vary across inspections or when using more than 5 sensors.

A System level custom map is supported for additional flexibility. When Custom Map is selected, a customizable space is used in the offset range (30056 to 30167) MODBUS/TCP registers.

The following is a table of MODBUS/TCP registers 30001 to 30240 when using Custom Map setting.

WORD #	WORD NAME	Data Type
30001	Inputs Bits ACK Register	16-bit integer
30002	Output Bits Register	16-bit integer
30003-4	Error Code	32-bit integer
30005-6	Inspection Number	32-bit integer
30007-8	Iteration Count	32-bit integer
30009-10	Pass Count	32-bit integer
30011-12	Fail Count	32-bit integer
30013-14	Missed Triggers	32-bit integer
30015-16	Current Inspection Time	Float
30017	Sensor Pass/Fail Coil	16-bit integer
30018-30	<i>reserved</i>	
30031-53	Inspection Name	2-Word Length + 20-unicode chars
30054-55	Frame Number	32-bit integer
30056-67	Customizable Space (112 reg)	
30168-171	<i>reserved</i>	
30172	Command Status	16-bit integer
30173	Command Response Int16	16-bit integer
30174-175	Command Response Int32	32-bit integer
30176-177	Command Response Float	Float
30178-179	Command Response Length	32-bit integer
30180-229	Command Response Data	100 Byte Array
30230-240	<i>reserved</i>	

Configure Custom Map

Enable Custom Map by selecting Custom on the drop down list.

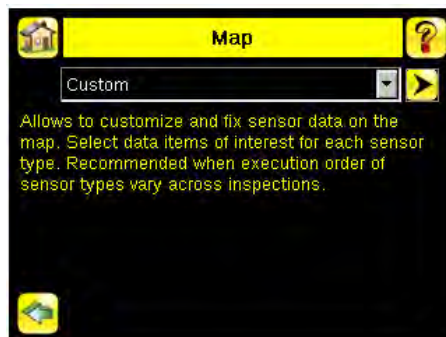

Click on the yellow arrow button to Custom IE Map screen. Custom IE Map screen allows choosing sensor result data that will appear on the customizable space.



The bottom of the screen shows the word usage on the customizable space. In the screenshot above, seven words have been used for one Area sensor "Area (1)". Use the yellow arrow button next to the Area sensor row to go to the "Area Sensor Data" in the following graphic.

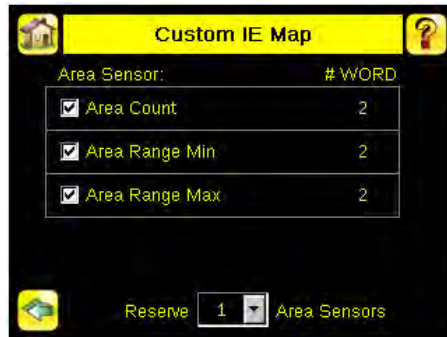

On the "Area Sensor Data" screen above, "Area Count", "Area Range Min" and "Area Range Max" are available to add into the customizable space. The number to the right of each item shows how many words are required to display the data. The bottom reservation count shows the number of Area Sensors that will be reserved on the customizable space.

Since only one Area Sensor's worth of data is reserved on the screenshot above, the selected data will be collected from the first Area sensor in the current inspection. When multiple Area Sensors have been reserved, the data will be arranged in the sequential manner of the sensor type in the current inspection.

Use the green arrow icon (Back) button to go back to the custom map summary screen.



User may continue to add more data from any sensor type as required or reserve more sensors into the customizable space.

"Sensor Name" and "Sensor Type ID" are global settings that are part of any individual sensor reservation. When they are checked, they will be inserted into each sensor reservation.

Here is an example of multiple sensors inspection and its output location on the customizable space.

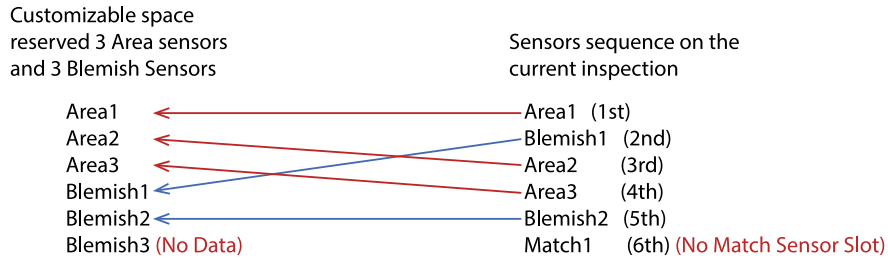

There are only 2 Blemish sensors on the current inspection; Blemish3 location will be all zero on the customizable space. The customizable space had not reserved a Match sensor, Match1 from the inspection will not be outputted on the customizable space.

7.5.4 Input and Output Coils

The Modbus/TCP Input Coil Bits are used to push single bit commands from the PLC/HMI to the iVu Plus sensor. To access the Modbus/TCP Coil ACK Bits (reg. 30001) and Status Coil Bits (reg. 30002) use Function Code 02 (Read Input Status).

Input Coil Bits

Bit Position

15	14	13	12	11	10	9	8	7	6	5	4	3	2	1	0
Command									Set BCR Mask	Set BCR String		Gated Trigger	Trigger	Teach Latch	Product Change

Input Coil ACK Bits

Bit Position

15	14	13	12	11	10	9	8	7	6	5	4	3	2	1	0
Command ACK									Set BCR Mask ACK	Set BCR String ACK		Gated Trigger ACK	Trigger ACK	Teach Latch ACK	Product Change ACK

Status Coil Bits

Bit Position

15	14	13	12	11	10	9	8	7	6	5	4	3	2	1	0
Execution Error	System Error	Teach Error	Missed Trigger					Output 3	Output 2	Output 1		Ready Latch	Read/No Read	Pass/Fail	Ready

7.6 PLC5 and SLC 5 (PCCC)

Allen-Bradley's PLC5 and SLC 500 family of devices use PCCC communications protocol. iVu Plus supports these PLCs using input and output register arrays. The Output Flags, ACK Flags and Input Flags bit definitions are the same as defined in the EIP Assembly Objects section. The terms "Input" and "Output" are from the point of view of the PLC.

7.6.1 Configuration

The images below represent a typical configuration:

1. Read. Message command_reading from N7 tabe on iVu Plus

The screenshot shows the configuration window for a message object named "MSG - N20:0: (51 Elements)". The window is divided into several sections:

- General:** MultiHop
- This Controller:**
 - Communication Command: PLC5 Read
 - Data Table Address: N7:0
 - Size in Elements: 100
 - Channel: 1
- Target Device:**
 - Message Timeout: 23
 - Data Table Address: N7:0
 - Local / Remote: Local
 - MultiHop: Yes
- Control Bits:**
 - Ignore if timed out (TO): 0
 - To be retried (NR): 0
 - Awaiting Execution (EW): 0
 - Continuous Run (CO): 0
 - Error (ER): 0
 - Message done (DN): 0
 - Message Transmitting (ST): 1
 - Message Enabled (EN): 1
 - Waiting for Queue Space: 0
- Error:**
 - Error Code(Hex): 0
- Error Description:**
 - No errors

2. Read. IP Address of the iVu Plus is entered here.

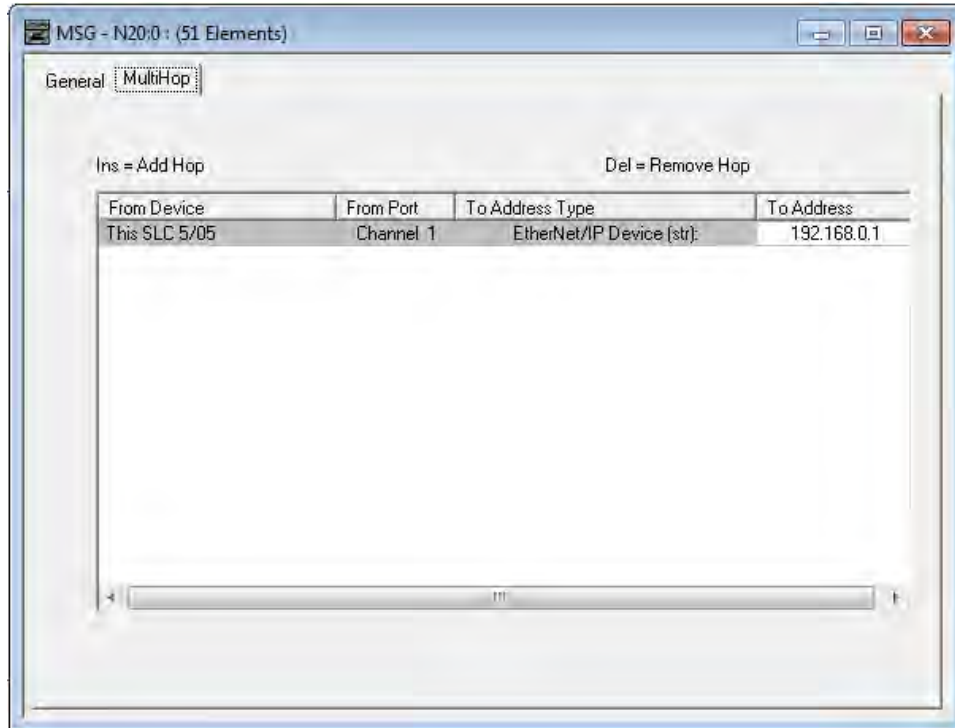

3. Write. Message command_writing to N14 table on iVu Plus

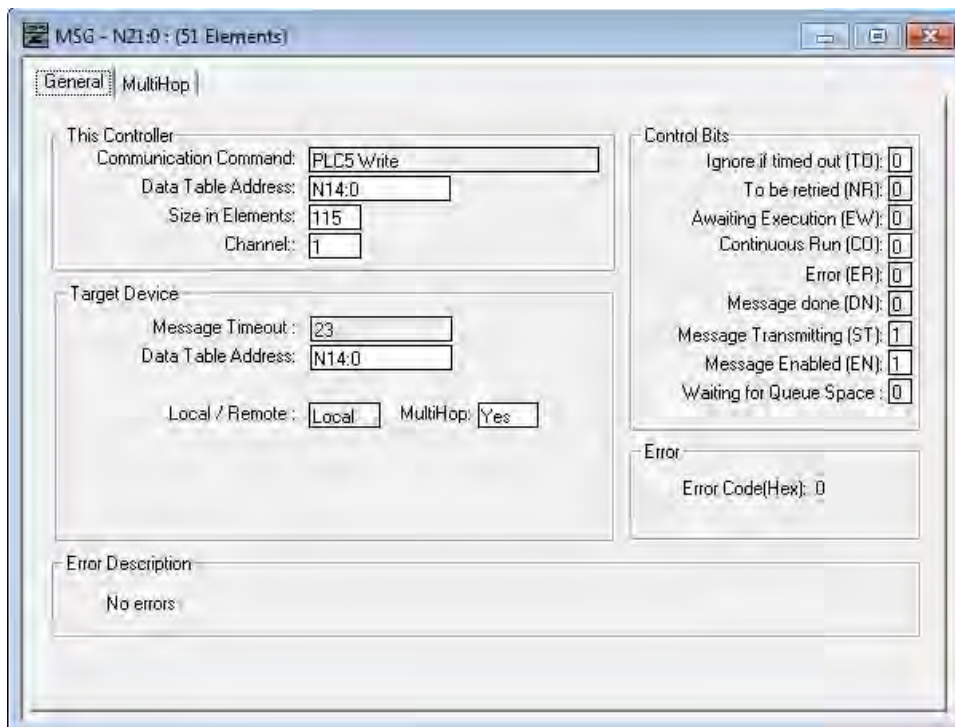

4. Write. IP Address of the iVu Plus is entered here.

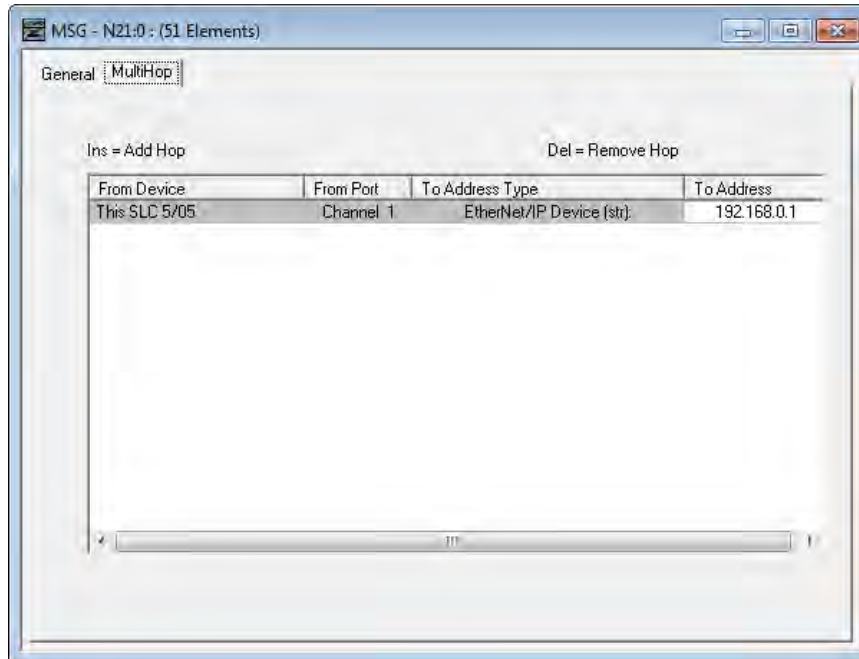

7.6.2 Inputs to iVu (Outputs from PLC)

The Input registers are used by the PLC to push values to the iVu Plus sensor. MSG (message) commands are used to Read (N7) and Write (N14) to the sensor.

Table 26: PLC Output Registers Map (N14) (iVu Inputs)

WORD #	WORD NAME	DATA TYPE
0	Input Bits Register (see Input and Output Flags on page 138)	16-bit integer
1-2	Product Change Number	32-bit integer
3-49	<i>reserved</i>	32-bit integer
50	Command ID	16-bit integer
51	Command Parameter Int16	16-bit integer
52-53	Command Parameter Int 32	32-bit integer
54-55	Command Parameter	Float
56-57	Command Parameter String Length	32-bit integer
58-107	Command Parameter String	100 Byte Array
108	<i>reserved</i>	16-bit integer
109-110	BCR String/Mask Length	32-bit integer
111-120	BCR String/Mask	200 Byte Array
211-239	<i>reserved</i>	

7.6.3 Outputs from iVu (Inputs to PLC)

The Output registers are used to push output values from the iVu Plus to the PLC. MSG (message) commands are used to Read (N7) and Write (N14) to the sensor.

PLC Input Registers Map (N7) (iVu Outputs)

Table 27: Sensor Type - Area (iVu Plus TG)

WORD #	WORD NAME	DATA TYPE
0	Input Bits ACK Register (see Input and Output Flags on page 138)	16-bit integer
1	Output Bits Register (see Input and Output Flags on page 138)	16-bit integer
2-3	Error Code	32-bit integer
4-5	Inspection Number	32-bit integer
6-7	Iteration Count	32-bit integer
8-9	Pass Count	32-bit integer
10-11	Fail Count	32-bit integer
12-13	Missed Triggers	32-bit integer
14-15	Current Inspection Time	Float
16	Sensor Pass/Fail Coil	
17-29	<i>reserved</i>	
30-52	Inspection Name	2-Word Length + 20-unicode chars
53-54	Frame Number	32-bit integer
55	Sensor Type ID	16-bit integer
56-57	Area Count	32-bit integer
58-59	Area Range Min	32-bit integer
60-61	Area Range Max	32-bit integer
62-170	<i>reserved</i>	
171	Command Status	16-bit integer
172	Command Response Int16	16-bit integer
173-174	Command Response Int32	32-bit integer
175-176	Command Response	Float
177-178	Command Response Length	32-bit integer
179-228	Command Response Data	100 Byte Array
229-239	<i>reserved</i>	

Table 28: Sensor Type - Blemish (iVu Plus TG)

WORD #	WORD NAME	DATA TYPE
0	Input Bits ACK Register (see Input and Output Flags on page 138)	16-bit integer
1	Output Bits Register (see Input and Output Flags on page 138)	16-bit integer
2-3	Error Code	32-bit integer
4-5	Inspection Number	32-bit integer
6-7	Iteration Count	32-bit integer
8-9	Pass Count	32-bit integer
10-11	Fail Count	32-bit integer
12-13	Missed Triggers	32-bit integer
14-15	Current Inspection Time	Float
16	Sensor Pass/Fail Coil	
17-29	<i>reserved</i>	
30-52	Inspection Name	2-Word Length + 20-unicode chars
53-54	Frame Number	32-bit integer
55	Sensor Type ID	16-bit integer
56-57	Blemish Count	32-bit integer
58-59	Blemish Min Edge Length	32-bit integer
60-61	Blemish Max Edge Length	32-bit integer
62-170	<i>reserved</i>	
171	Command Status	16-bit integer
172	Command Response Int16	16-bit integer
173-174	Command Response Int32	32-bit integer
175-176	Command Response	Float
177-178	Command Response Length	32-bit integer
179-228	Command Response Data	100 Byte Array
229-239	<i>reserved</i>	

Table 29: Sensor Type - Match (iVu Plus TG)

WORD #	WORD NAME	DATA TYPE
0	Input Bits ACK Register (see Input and Output Flags on page 138)	16-bit integer
1	Output Bits Register (see Input and Output Flags on page 138)	16-bit integer
2-3	Error Code	32-bit integer
4-5	Inspection Number	32-bit integer
6-7	Iteration Count	32-bit integer
8-9	Pass Count	32-bit integer
10-11	Fail Count	32-bit integer
12-13	Missed Triggers	32-bit integer
14-15	Current Inspection Time	Float
16	Sensor Pass/Fail Coil	
17-29	<i>reserved</i>	
30-52	Inspection Name	2-Word Length + 20-unicode chars
53-54	Frame Number	32-bit integer
55	Sensor Type ID	16-bit integer
56-57	Match Count	32-bit integer
58	Match Min Percent Match	16-bit integer
59	Match Max Percent Match	16-bit integer
60-170	<i>reserved</i>	
171	Command Status	16-bit integer
172	Command Response Int16	16-bit integer
173-174	Command Response Int32	32-bit integer
175-176	Command Response	Float
177-178	Command Response Length	32-bit integer
179-228	Command Response Data	100 Byte Array
229-239	<i>reserved</i>	

Table 30: Sensor Type - Sort (iVu Plus TG)

WORD #	WORD NAME	DATA TYPE
0	Input Bits ACK Register (see Input and Output Flags on page 138)	16-bit integer
1	Output Bits Register (see Input and Output Flags on page 138)	16-bit integer
2-3	Error Code	32-bit integer
4-5	Inspection Number	32-bit integer
6-7	Iteration Count	32-bit integer
8-9	Pass Count	32-bit integer
10-11	Fail Count	32-bit integer
12-13	Missed Triggers	32-bit integer
14-15	Current Inspection Time	Float
16	Sensor Pass/Fail Coil	
17-29	<i>reserved</i>	
30-52	Inspection Name	2-Word Length + 20-unicode chars
53-54	Frame Number	32-bit integer
55	Sensor Type ID	16-bit integer
56	Sort Pattern Map	16-bit integer
57	Sort Pattern Count	16-bit integer
58	Sort Pattern 1 Count	16-bit integer
59	Sort Pattern 2 Count	16-bit integer
60	Sort Pattern 3 Count	16-bit integer
61	Sort Pattern 4 Count	16-bit integer
62	Sort Pattern 5 Count	16-bit integer
63	Sort Pattern 6 Count	16-bit integer
64	Sort Pattern 7 Count	16-bit integer
65	Sort Pattern 8 Count	16-bit integer
66	Sort Pattern 9 Count	16-bit integer
67	Sort Pattern 10 Count	16-bit integer
68	Sort Min Percent Match	16-bit integer
69	Sort Max Percent Match	16-bit integer
70-170	<i>reserved</i>	
171	Command Status	16-bit integer
172	Command Response Int16	16-bit integer
173-174	Command Response Int32	32-bit integer
175-176	Command Response	Float
177-178	Command Response Length	32-bit integer
179-228	Command Response Data	100 Byte Array
229-239	<i>reserved</i>	

7.6.4 Multiple Sensors Mapping Options

When using an iVu Plus TG with multiple sensors in an inspection, there are two mapping options: Default and Custom.

Default Map

Main Menu > System > Communications > Industrial EtherNet > Map > Default

Automatically maps sensor data for each inspection. Recommended when execution order of sensor types is the same across inspections. When inspection has multiple sensors, the first 5 sensor results will be shown starting at offset 55. Each sensor result will occupy 20 words.

The following is a table of PCCC PLC Input Registers Map (N7) when using Default Map setting.

WORD #	WORD NAME	Data Type
0	Input Bits ACK Register	16-bit integer
1	Output Bits Register	16-bit integer
2-3	Error Code	32-bit integer
4-5	Inspection Number	32-bit integer
6-7	Iteration Count	32-bit integer
8-9	Pass Count	32-bit integer
10-11	Fail Count	32-bit integer
12-13	Missed Triggers	32-bit integer
14-15	Current Inspection Time	Float
16	Sensor Pass/Fail Coil	16-bit integer
17-29	reserved	
30-52	Inspection Name	2-Word Length + 20-Unicode chars
53-54	Frame Number	32-bit integer
55	Sensor Type ID (Sensor 1)	16-bit integer
56-74	Sensor 1 Specific Data	16-bit integer
75	Sensor Type ID (Sensor 2)	16-bit integer
76-89	Sensor 2 Specific Data	16-bit integer
95	Sensor Type ID (Sensor 3)	16-bit integer
95-114	Sensor 3 Specific Data	16-bit integer
115	Sensor Type ID (Sensor 4)	16-bit integer
116-134	Sensor 4 Specific Data	16-bit integer
135	Sensor Type ID (Sensor 5)	16-bit integer
136-154	Sensor 5 Specific Data	16-bit integer
155-170	reserved	
171	Command Status	16-bit integer
172	Command Response Int16	16-bit integer
173-174	Command Response Int32	32-bit integer
175-176	Command Response Float	Float
177-178	Command Response Length	32-bit integer
179-228	Command Response Data	100 Byte Array
229-239	reserved	

If the inspection contains more than 5 sensors, the sensor(s) after the 5th one will not be on the map.

Table 31: Area Sensor Type ID = 2

Sensor Specific Data	Data Size
Area Count	32-bit integer

Sensor Specific Data	Data Size
Area Range Min	32- bit integer
Area Range Max	32- bit integer

Table 32: Blemish Sensor Type ID = 3

Sensor Specific Data	Sensor Location
Blemish Count	32- bit integer
Blemish Min Edge Length	32- bit integer
Blemish Min Edge Length	32- bit integer

Table 33: Match Sensor Type ID = 4

Sensor Specific Data	Sensor Location
Match Count	32- bit integer
Match Min Percent	16- bit integer
Match Max Percent	16- bit integer

Table 34: Sort Sensor Type ID = 5

Sensor Specific Data	Sensor Location
Sort Pattern Map	16-bit integer
Sort Pattern Count	16-bit integer
Sort Pattern 1 Count	16-bit integer
Sort Pattern 2 Count	16-bit integer
Sort Pattern 3 Count	16-bit integer
Sort Pattern 4 Count	16-bit integer
Sort Pattern 5 Count	16-bit integer
Sort Pattern 6 Count	16-bit integer
Sort Pattern 7 Count	16-bit integer
Sort Pattern 8 Count	16-bit integer
Sort Pattern 9 Count	16-bit integer
Sort Pattern 10 Count	16-bit integer
Sort Min Percent Match	16-bit integer
Sort Max Percent Match	16-bit integer

Custom Map

Main Menu > System > Communications > Industrial EtherNet > Map > Custom

Allows customization of fix sensor data on the map. Select data items of interest for each sensor type. Recommended when execution order of sensor types vary across inspections or when using more than 5 sensors.

A System level custom map is supported for additional flexibility. When Custom Map is selected, a customizable space is used in the offset range (55 to 166) on PCCC registers.

The following is a table of PCCC PLC Input Registers Map (N7) when using Custom Map setting.

WORD #	WORD NAME	Data Type
0	Input Bits ACK Register	16-bit integer
1	Output Bits Register	16-bit integer
2-3	Error Code	32-bit integer

WORD #	WORD NAME	Data Type
4-5	Inspection Number	32-bit integer
6-7	Iteration Count	32-bit integer
8-9	Pass Count	32-bit integer
10-11	Fail Count	32-bit integer
12-13	Missed Triggers	32-bit integer
14-15	Current Inspection Time	Float
16	Sensor Pass/Fail Coil	16-bit integer
17-29	<i>reserved</i>	
30-52	Inspection Name	2-Word Length + 20-unicode chars
53-54	Frame Number	32-bit integer
55-166	Customizable Space (112 reg)	
167-170	<i>reserved</i>	
171	Command Status	16-bit integer
172	Command Response Int16	16-bit integer
173-174	Command Response Int32	32-bit integer
175-176	Command Response Float	Float
177-178	Command Response Length	32-bit integer
179-228	Command Response Data	100 Byte Array
229-239	<i>reserved</i>	

Configure Custom Map

Enable Custom Map by selecting Custom on the drop down list.

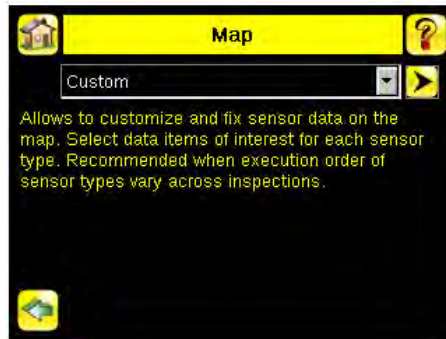

Click on the yellow arrow button to Custom IE Map screen. Custom IE Map screen allows choosing sensor result data that will appear on the customizable space.



The bottom of the screen shows the word usage on the customizable space. In the screenshot above, seven words have been used for one Area sensor "Area (1)". Use the yellow arrow button next to the Area sensor row to go to the "Area Sensor Data" in the following graphic.

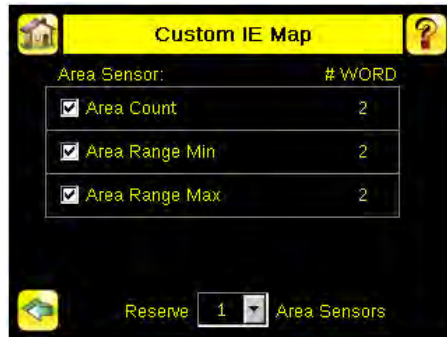

On the "Area Sensor Data" screen above, "Area Count", "Area Range Min" and "Area Range Max" are available to add into the customizable space. The number to the right of each item shows how many words are required to display the data. The bottom reservation count shows the number of Area Sensors that will be reserved on the customizable space.

Since only one Area Sensor's worth of data is reserved on the screenshot above, the selected data will be collected from the first Area sensor in the current inspection. When multiple Area Sensors have been reserved, the data will be arranged in the sequential manner of the sensor type in the current inspection.

Use the green arrow icon (Back) button to go back to the custom map summary screen.



User may continue to add more data from any sensor type as required or reserve more sensors into the customizable space.

"Sensor Name" and "Sensor Type ID" are global settings that are part of any individual sensor reservation. When they are checked, they will be inserted into each sensor reservation.

Here is an example of multiple sensors inspection and its output location on the customizable space.

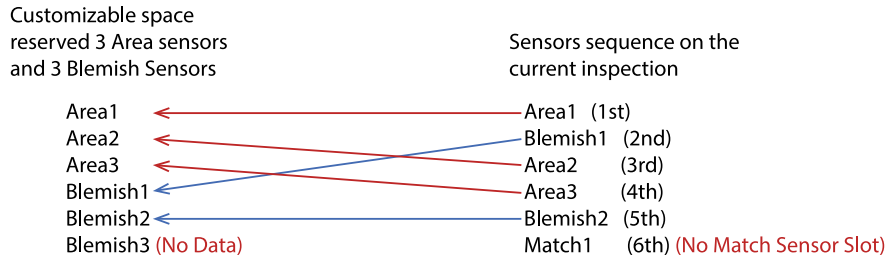

There are only 2 Blemish sensors on the current inspection; Blemish3 location will be all zero on the customizable space. The customizable space had not reserved a Match sensor, Match1 from the inspection will not be outputted on the customizable space.

7.6.5 Input and Output Flags

The Input Bits are used to command execution of basic functions. The Output Bits are used to push single bit outputs from the iVu Sensor to the PLC. The 32 bits of iVu output can also be accessed using the bits of the first two Output Registers (Input Bits ACK Register(word 0) and Output Bits Register (word1)).

Input Bits Register

Bit Position

15	14	13	12	11	10	9	8	7	6	5	4	3	2	1	0
Command									Set BCR Mask	Set BCR String		Gated Trigger	Trigger	Teach Latch	Product Change

Input Bits ACK Register

Bit Position

15	14	13	12	11	10	9	8	7	6	5	4	3	2	1	0
Command ACK									Set BCR Mask ACK	Set BCR String ACK		Gated Trigger ACK	Trigger ACK	Teach Latch ACK	Product Change ACK

Output Bits Register

Bit Position

15	14	13	12	11	10	9	8	7	6	5	4	3	2	1	0
Execution Error	System Error	Teach Error	Missed Trigger					Output 3	Output 2	Output 1		Ready Latch	Read/No Read	Pass/Fail	Ready

7.7 Sample Timing Diagram

X, Y, Z: Represent snapshot in time

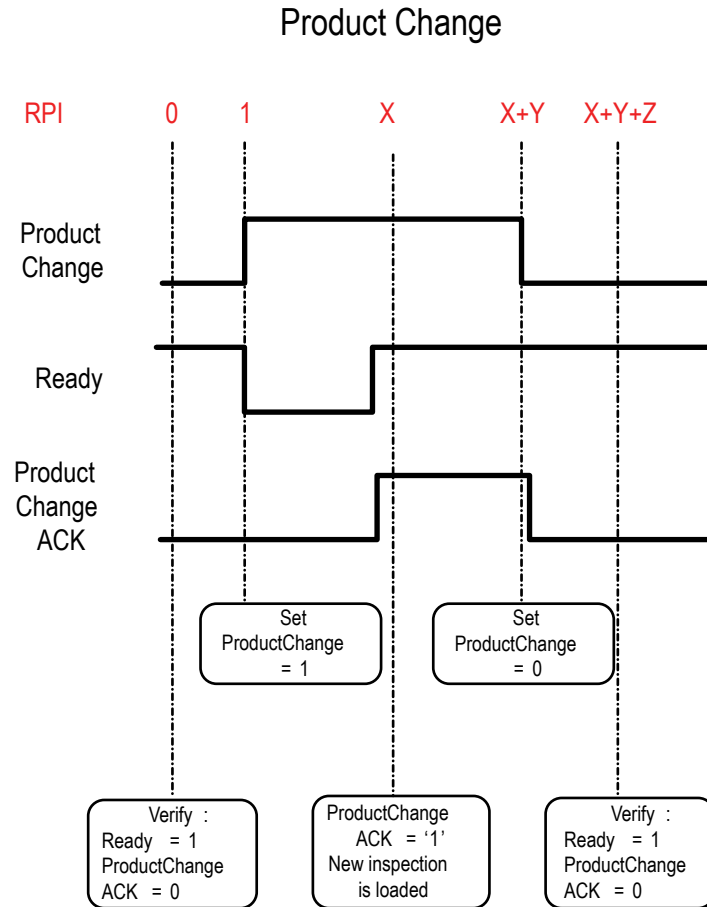

Teach Latch

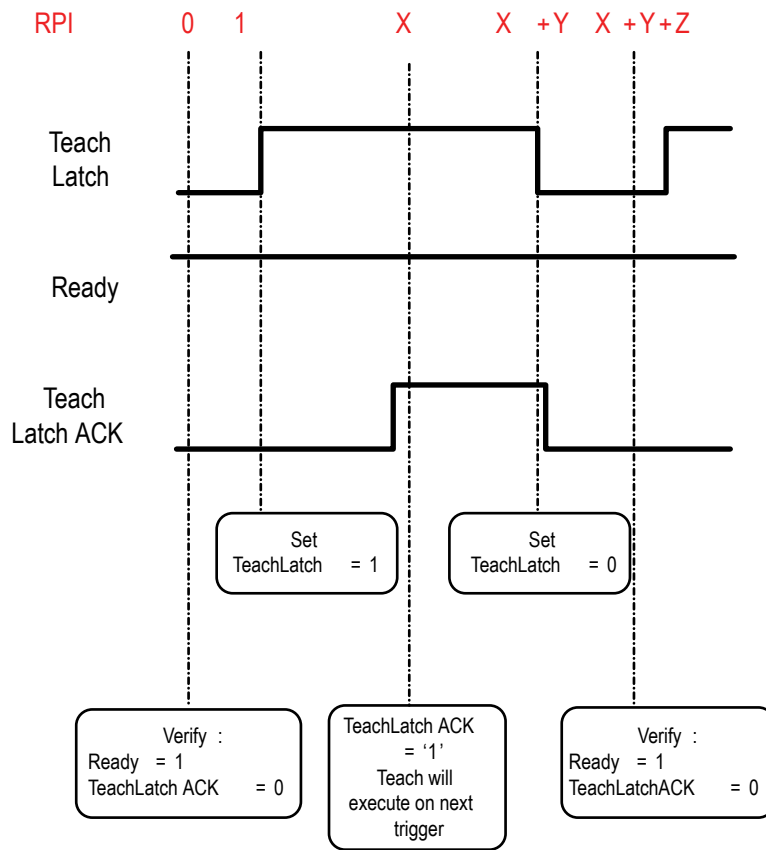

Trigger

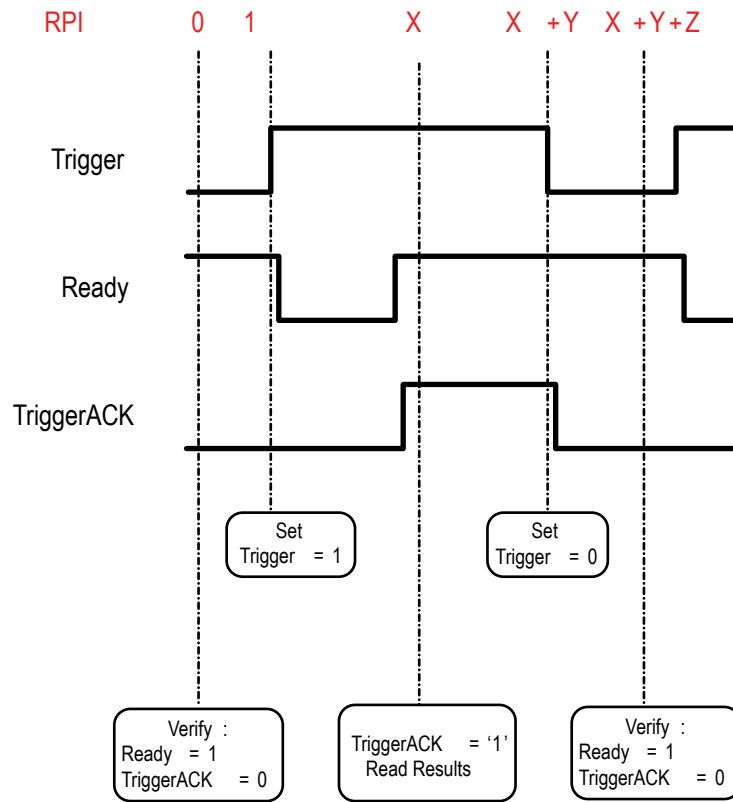

Gated Trigger

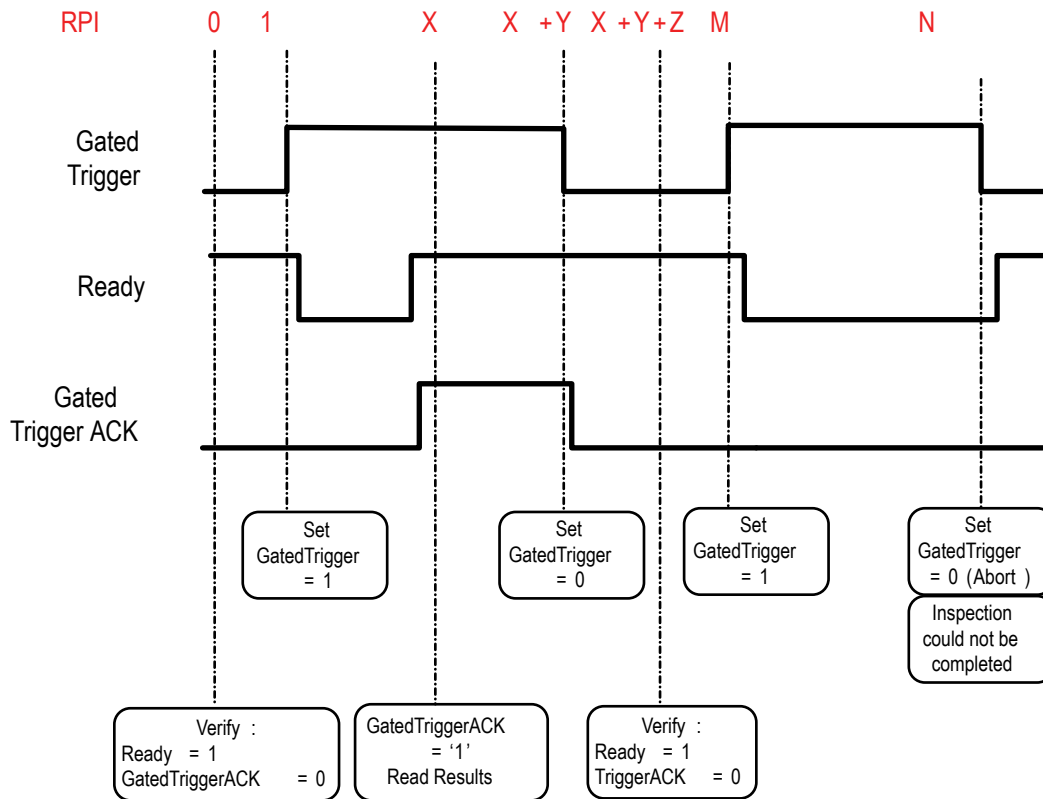

7.8 Command Channel Command Status Register

The command status is a verification of the command type.

Command Status	Value (16-bit integer)
Unknown	0
Read	1
Write	2
Execute	3

7.9 Diagnostic Guide

iVu Plus sensors provide several methods to help diagnose communication issues when using Ethernet communications.

7.9.1 Ethernet Diagnostics

To verify Ethernet connectivity, follow these steps:

1. Verify that all the cables are connected and properly seated.

- Examine the small orange Ethernet link light located on the top of camera body, between the Pass/Fail and System Status LEDs. The light should be either on or blinking.
- Go to the System > Logs > System Log page, and verify that the log entry indicates that the Ethernet link is up:



- Go to the System > Communications > Ethernet I/O page, and press on the Status button. Verify that the Ethernet Link Status is "Connected", and that the link parameters, such as baud rate and duplex are as expected. For example:

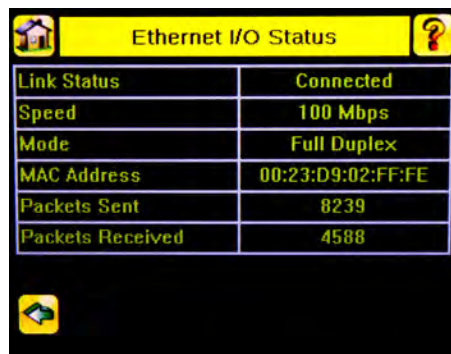

- If the Link Status indicates that there is no link, please inspect the wiring, and verify that your Ethernet switch is powered up.
- If the link parameters are not as expected (wrong baud rate or duplex) try the following:
 - Log into your managed switch and verify that the port to which iVu camera is connected is correctly configured. Alternatively, consult with your IT person to perform this verification.
 - Verify that your cable is of the right type, and is properly connected to the switch and to the camera.

7.9.2 Networking and TCP/IP Diagnostics

To verify networking and TCP/IP connectivity, follow these steps:

- Verify that the Ethernet link has been established.
- Visit the System > Communications > Ethernet I/O page, and examine the sensor IP address, subnet mask, and the Gateway address:

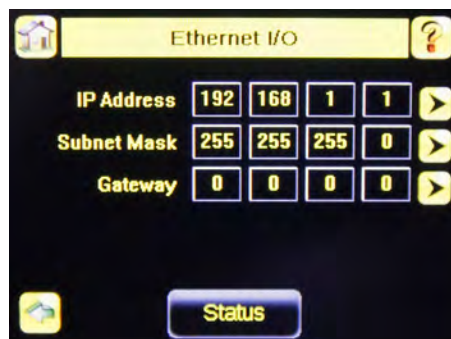

- Verify with your IT person that these settings are correct.
 - If necessary, make the required modifications and reboot the sensor

4. Press the Status button on the same page, and go to the Ethernet I/O Status page:

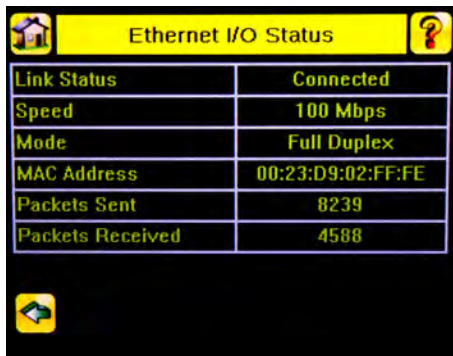

5. On the PC attached to your LAN, open the Command window. To do this, press Start > Run, and then type in `cmd` and press the OK button.
6. A command window will display:



7. Type in a ping command, specifying the sensor IP address as an argument. You should see a series of responses from the camera:

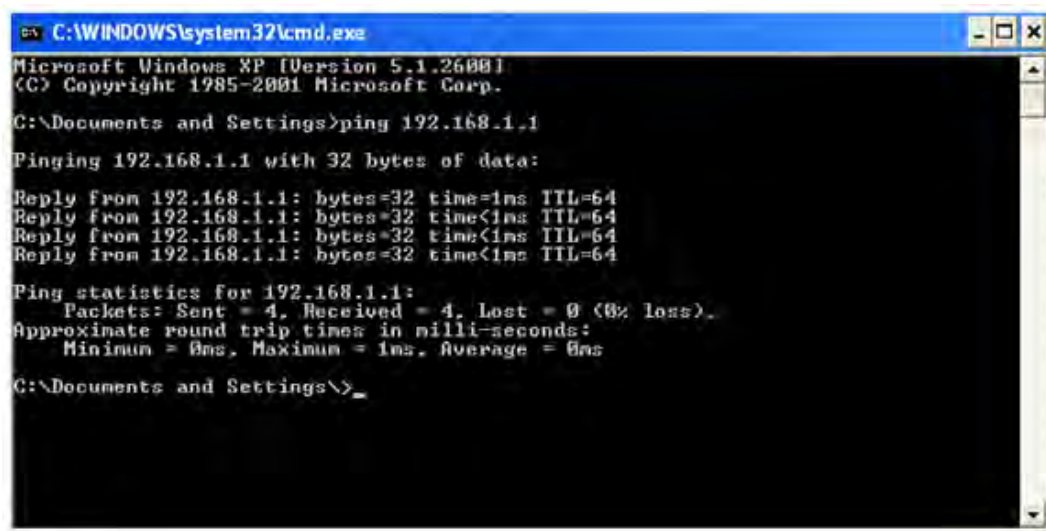

8. You should also see the Packets Received and Packets Sent count on the Ethernet I/O Status page in the camera increment by at least 4.
9. If the output of the ping command shows request timeouts, try the following:
 - Verify that the camera is located on the correct subnet, has the correct IP address, and is connected to the correct switch or router.
 - If you are running several overlapping subnets, you may want to consult your IT person to ensure that the routing for the network is configured correctly.
 - If you are trying to access the camera through a gateway or a VPN router, please verify that these devices are configured such that they allow traffic from iVu camera to reach the destination device.

7.9.3 Industrial Protocols Troubleshooting

Modbus/TCP Protocol

Modbus/TCP protocol relies on the fundamental TCP/IP connectivity to establish connections and transport data. Once you have verified Networking and TCP/IP connectivity, you should have little or no problems establishing a Modbus/TCP connection.

iVu supports one Modbus/TCP connection from a single client, and will reject additional connection requests.

Prior to attempting to establish the Modbus/TCP connection, you will have to configure your device, and teach it about the iVu sensor. You will have to tell it the IP address of the iVu sensor that you have previously configured. Configurations steps vary for each device, so you will have to consult the appropriate manual for these steps.

If your device has user-configurable Modbus/TCP port, please verify that it is set to port number 502. iVu will not accept connections on any other port.

Once you have established a Modbus/TCP connection, you can verify that iVu has accepted it by going to the System > Communications > Industrial Ethernet > Status page, and viewing the connection status:

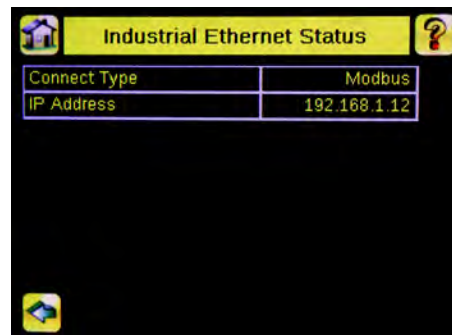

If you experience issues accessing data, please consult the relevant sections of the manual for the Modbus/TCP register maps supported by the sensor, and consult the Industrial Protocols Log. The log, when configured to Detailed Logging mode, provides record of individual register access sequence, and records any errors:

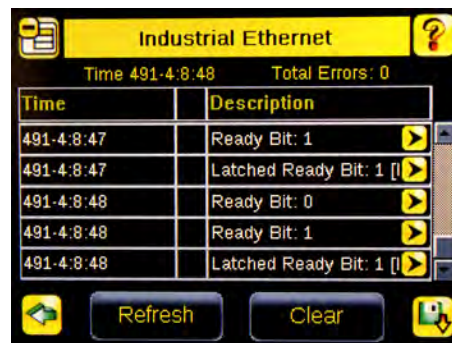

EtherNet/IP and PCCC Protocols

EtherNet/IP and PCCC protocols rely on CIP protocol to establish communications and exchange data. CIP protocol, in turn, utilizes TCP/IP.

In addition, EtherNet/IP implements I/O messaging. I/O messaging allows two devices, iVu sensor and the PLC, to continuously synchronize data sets between each other. These data sets are called Input and Output Assemblies. iVu device consumes PLC output assemblies, and produces PLC input assemblies. This exchange occurs continuously, and the rate specified by the RPI (requested Packet Interval) value.

I/O messaging is based on UDP/IP, and utilizes Multicast addressing when sending PLC input assemblies. It is the default mode of operation for I/O messages in PLCs. Newer PLCs also support Unicast (direct) addressing for PLC input assemblies, but need to be specially configured.

Because I/O messaging uses IDP/IP and Multicast, it requires special, managed switches, and customized switch configuration. Managed switches, when properly configured, prevent multicast devices from flooding the network with data. Please consult your IT person to make sure that you have the correct switch type, and that these switches have IGMP snooping enabled, to allow them to manage multicast groups.

In addition, some switches with built-in firewalls block UDP traffic by default. If this is the case, and if the path between your devices involves several switches or routers, it is possible that some of them might block the UDP traffic necessary for I/O messages. Please consult your IT person to verify that your network is configured correctly. Also consult Rockwell publications ENET-AP001D-EN-P, *EtherNet/IP Performance*, and ENET-SO001A-EN-E, *EtherNet Design Considerations for Control System Networks* for further information on how to configure your EtherNet network for EtherNet/IP.

Establishing CIP and EtherNet/IP I/O communications is a complicated process. There are a number of steps during which an error can occur. Industrial Protocols log contains a detail description of the communications process, and should be consulted if any errors are suspected.



A great level of detail is also provided in the log when the I/O connection is established:

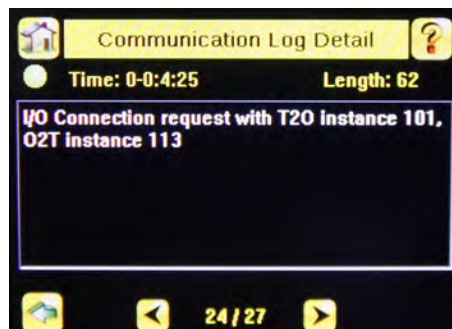
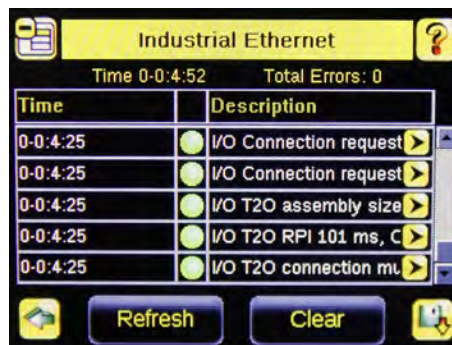

After the CIP and I/O connections are established, the Industrial Protocols Status page will show the details of the connection:

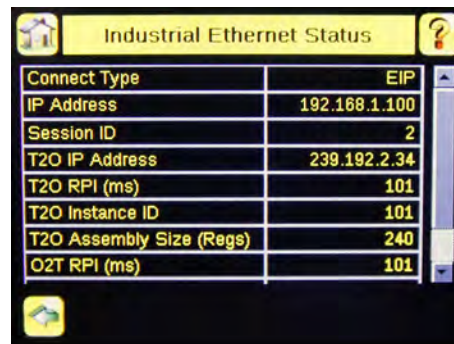

Industrial Ethernet Status	
Connect Type	EIP
IP Address	192.168.1.100
Session ID	2
T2O IP Address	239.192.2.34
T2O RPI (ms)	101
T2O Instance ID	101
T2O Assembly Size (Regs)	240
O2T RPI (ms)	101

Most of the errors in establishing the CIP and I/O connections have to do with specifying the proper Input and Output assembly IDs and sizes. Please refer to the appropriate sections of this manual for this information.

7.10 Additional Information

7.10.1 iVu Command Channel Commands (iVu Command Channel over Industrial EtherNet)

This section describes how to use the iVu Command Channel over Industrial EtherNet. Please see the iVu Plus Communications User's Guide for more information on the iVu Command Channel protocol. The following commands need to be executed using the Command ID register and the Command Input bit/Input Coil bit.

Command	Command ID			Description	Data Type
	Do	Set	Get		
Trigger					
Trigger Mode		1	10001	The sensor's triggering mode. This value must match the modes supported by the sensor	Int16
Product Change					
Product Change By Name	21			This command forces the sensor to switch to the specified inspection. The sensor does not transmit a response until the sensor has completed the action. Inspections results immediately after a product change will be invalid until a new trigger is received.	Byte Array
Imager					
Gain		51	10051	The sensor's value used to electronically brighten all image pixels	Int32
Exposure		52	10052	The sensor's value used to control the amount of time the imager is allowed to gather light for the image.	Int32
Status					
Clear System Error	81			This command clears the system error LED and resets the internal system error flag to false.	N/A
System					
Reboot Sensor	101			This command reboots the sensor. If sensor configuration data is being currently being saved, this command will block until that operation completes	N/A
Save Configuration	102			This command saves all modified inspection and configuration parameters. This command blocks until all values have been persisted	N/A

Command	Command ID			Description	Data Type
	Do	Set	Get		
Info					
Sensor Name			10151	Sensor user assignable name.	Byte Array
Model Number			10152	Sensor model number	Byte Array
Serial Number			10153	Sensor serial number	Byte Array
Firmware Version			10154	Sensor firmware (software) version	Byte Array
Hour Counter			10155	The total number of hours the sensor has been energized.	Byte Array
History					
Clear History	301			This command clears all history fields for the active inspection. History values include pass count, fail count, execution times and sensor specific history values.	N/A
Inspection					
Inspection Name			10501	The name of the active inspection.	Byte Array
BCR inputs					
Compare String			11001	The Barcode inspection compare data string. This string must start and end with the double quote character	Byte Array
Compare Mask			11002	The Barcode inspection compare string mask in binary format; that is, masked characters are indicated by a "1" and unmasked characters are "0." Note that the mask character string must match the length of the compare string	Byte Array

Trigger Mode	1000	Description
External	1	Inspections will be initiated via the electrical trigger wire
Internal	2	Inspections will run continuously at the specified period (electrical trigger inputs are ignored)
FreeRun	3	Inspections will run continuously (electrical trigger inputs are ignored)
ExternalGated	4	Gated barcode inspection will be started and/or aborted via the electrical trigger wire
ContinuousScan	5	Inspections will run continuously (electrical trigger inputs are ignored)
IndustrialEtherNet	10	Inspections will only be triggered by Industrial Ethernet coils and commands.
Command	20	Inspections will only be triggered by the Command Channel trigger commands.

Error Codes

The iVu Plus sensor provides error codes in cases when commands failed to execute successfully. If such an error occurs, the Execution Error flag is set in the Output Bits/Status Register. When this bit is set, read the Error Code register to know the reason of failure. Below is the list of error codes:

Numeric ID	Text ID	Description
0	SUCCESS	Command processed successfully.
500	IE_TRIGGER_MODE_EXPECTED	The Trigger Mode must be set to 'Industrial Ethernet' to perform this operation.
510	IE_COMMAND_NOT_FOUND	The numeric Command ID specified was not found.
520	IE_COIL_ACTION_FAILED	The coil action resulted in a failure.
521	IE_COIL_ALREADY_BUSY	The coil was asserted before previous execution completed.

Numeric ID	Text ID	Description
522	IE_COIL_NOT_FINISHED	The coil was de-asserted prior to execution completing.
523	IE_COIL_ANOTHER_ACTION_PENDING	The coil was asserted prior to another coil execution completing.
524	IE_COIL_MULTIPLES_DETECTED	Multiple coils were asserted simultaneously.
525	IE_COIL_ACK_INHIBITED	The coil action's output ACK was inhibited because the input coil was no longer set.
00000	SUCCESS	Command processed successfully
10000	EMPTY_FRAME_RECEIVED	Indicates that the request was empty. The command channel requires a command, any arguments, and an end-of-frame delimiter.
10001	COMMAND_NOT_RECOGNIZED	The command specified is not recognized
10100	GROUP_MISSING	A Group ID must be specified immediately after the command
10101	GROUP_NOT_FOUND	The specified Group ID is invalid / unknown
10102	GROUP_ITEM_MISSING	A Group Item ID must be specified immediately after the Group ID
10103	GROUP_ITEM_NOT_FOUND	The specified Group Item ID is invalid / unknown
10152	NOT_READABLE	Attempt to get a value that is not readable
10153	NOT_WRITEABLE	Attempt to set a value that is not writeable
10250	NOT_A_METHOD	Method ID specified is not a method
10251	WRONG_ARGUMENT_COUNT	Total method arguments specified do not match method
10252	COMMAND_NOT_FINISHED	Attempt to issue command when a previous command has not finished
10300	INVALID_ARGUMENT_TYPE	Item ID specified must be a item (not a group or method)
10301	DATA_VALUE_MISSING	Command missing item's data value
10340	MINIMUM_VALUE_EXCEEDED	New item value is below the minimum
10341	MAXIMUM_VALUE_EXCEEDED	New items value is above the maximum
10350	ARGUMENTS_DETECTED	Get command received with unneeded arguments
10351	INVALID_ARGUMENT_TYPE	Item ID specified must be a item (not a group or method)
10500	DATA_SET_EMPTY	Data export operation returned no results.
10900	SENSOR_NOT_READY	Command specified requires sensor to be in the READY state.
10920	SENSOR_TYPE_NOT_ACTIVE	Command specified belongs to a different sensor type.
10950	DEVICE_TYPE_INVALID	Command not supported on this device type.
15000	VALUE_INVALID	Text value is invalid / unknown
15050	VALUE_INVALID	Text value is invalid - expecting True or False
15100	STRING_TOO_LONG	String value specified exceeds maximum allowable length
20002	COMPARE_DATA_DISABLED	Operation requires Barcode compare to be enabled
20003	COMPARE_MASK_INVALID	Compare mask invalid. Expecting string of 1's and 0's with length equal to compare data string
20004	NUMBER_TO_FIND_NOT_ONE	Barcode number to find must be set to one for this operation.
20005	COMPARE_MASK_DISABLED	Operation requires Barcode compare mask to be enabled.
20200	NO_AREAS_FOUND	Attempt to obtain value when no areas were found.
20600	NO_MATCHES_FOUND	Attempt to obtain value when no matches were found.
20800	NO_MATCHES_FOUND	Attempt to obtain value when no sort patterns were found.
80000	REMOTE_DISPLAY_NOT_CONNECTED	Remote Display must be connected to obtain this value
80001	REMOTE_DISPLAY_NOT_SUPPORTED	This sensor does not have Remote Display capability
80100	COMMAND_MODE_EXPECTED	The Trigger Mode must be set to "Command" perform this operation

Numeric ID	Text ID	Description
80101	COMMAND_TIMED_OUT	The command timed out before finishing
80102	TRIGGER_REQUIRED	Access to the specified data requires a triggered inspection
80150	COMMAND_TIMED_OUT	The command timed out before finishing
80200	SYSTEM_ERROR_NOT_ACTIVE	The System Error must be active to execute this command
80300	TEACH_SENSOR_TYPE_INVALID	Teach requires Match Sensor type.
80350	MULTIPLE_INSPECTIONS_DISABLED	Requires multiple inspections to be enabled
80351	MULTIPLE_INSPECTIONS_EMPTY	No inspections are available in multiple inspection mode.
80400	PRODUCT_CHANGE_WHEN_NOT_READY	Sensor must be in the READY state to perform a product change.
80401	PRODUCT_CHANGE_INVALID_INSPECTION	Attempt to product change to a unknown or invalid inspection.
80402	PRODUCT_CHANGE_TIMEOUT	The Product Change operation timed out.
80403	PRODUCT_CHANGE_TO_SAME_INSPECTION	Attempt to product change to the same inspection.
80404	SENSOR_NAME_NOT_FOUND	Attempt to use a command without a sensor name in a multi-sensor inspection

Examples of Operation

The following examples show how the iVu Command Channel can be utilized via the Industrial Ethernet connection.

Clear System Error

1. Write the number 81 as a 16-bit integer into the Command ID register.
2. Toggle the Command bit from 0 to 1 (bit 15 in the Input Bits/Input Coil Bits register).
3. Wait for the Command ACK flag to go from 0 to 1 (bit 15 in the Input Bits ACK/Input Coil Bits ACK register).
4. Verify that the Execution Error flag is not set (i.e. value should be 0). This is bit 15 in the Output Bits/Status Coil Bits register. If the value is 1, read the Error Code register for more information.
5. Task Complete. Toggle the Command bit back to 0 (bit 15 in the Input Bits/Input Coil Bits register).

Get/Set Trigger Mode

Get the current Trigger Mode from the iVu Plus.

1. Write the number 10001 as a 16-bit integer into the Command ID register.
2. Toggle the Command bit from 0 to 1 (bit 15 in the Input Bits/Input Coil Bits register).
3. Wait for the Command ACK flag to go from 0 to 1 (bit 15 in the Input Bits ACK/Input Coil Bits ACK register).
4. Verify that the Execution Error flag is not set (i.e. value should be 0). This is bit 15 in the Output Bits/Status Coil Bits register. If the value is 1, read the Error Code register for more information.
5. Task Complete. Toggle the Command bit back to 0 (bit 15 in the Input Bits/Input Coil Bits register). Read the current Trigger Mode value in the Command Response Int16 register.

iVu model	Trigger Mode	Int16 value
TG, BCR	External	1
TG	Internal	2
TG	Free Run	3
TG, BCR	Industrial EtherNet Only	10
TG, BCR	Command	20
BCR	Continuous Scan	5
BCR	External Gated	4

Set the desired Trigger Mode for the iVu Plus:

1. Write the number 1 as a 16-bit integer into the Command ID register.
2. Write the desired Trigger Mode's Int16 value from the above table into the Command Parameter Int16 register.
3. Toggle the Command bit from 0 to 1 (bit 15 in the Input Bits/Input Coil Bits register).

4. Wait for the Command ACK flag to go from 0 to 1 (bit 15 in the Input Bits ACK/Input Coil Bits ACK register).
5. Verify that the Execution Error flag is not set (i.e. value should be 0). This is bit 15 in the Output Bits/Status Coil Bits register. If the value is 1, read the Error Code register for more information.
6. Task Complete. Toggle the Command bit back to 0 (bit 15 in the Input Bits/Input Coil Bits register).

Get/Set Exposure Time

Get the current Exposure Time from the iVu Plus.

1. Write the number 10052 as a 16-bit integer into the Command ID register.
2. Toggle the Command bit from 0 to 1 (bit 15 in the Input Bits/Input Coil Bits register).
3. Wait for the Command ACK flag to go from 0 to 1 (bit 15 in the Input Bits ACK/Input Coil Bits ACK register).
4. Verify that the Execution Error flag is not set (i.e. value should be 0). This is bit 15 in the Output Bits/Status Coil Bits register. If the value is 1, read the Error Code register for more information.
5. Task Complete. Toggle the Command bit back to 0 (bit 15 in the Input Bits/Input Coil Bits register). Read the current Exposure Time value (in microseconds) in the Command Response Int32 register.

Set the desired Exposure Time for the iVu Plus.

1. Write the number 52 as a 16-bit integer into the Command ID register.
2. Write the desired Exposure Time (in microseconds) as a 32-bit integer value into the Command Parameter Int32 register. The minimum acceptable value is 117 usec and the maximum value is 1,000,000 usec.
3. Toggle the Command bit from 0 to 1 (bit 15 in the Input Bits/Input Coil Bits register).
4. Wait for the Command ACK flag to go from 0 to 1 (bit 15 in the Input Bits ACK/Input Coil Bits ACK register).
5. Verify that the Execution Error flag is not set (i.e. value should be 0). This is bit 15 in the Output Bits/Status Coil Bits register. If the value is 1, read the Error Code register for more information.
6. Task Complete. Toggle the Command bit back to 0 (bit 15 in the Input Bits/Input Coil Bits register). The new exposure time will be used for the next inspection. Please note that this value is not saved to the iVu's permanent memory unless the Save Configuration task is completed.

Save iVu Configuration

This command saves all modified inspection and configuration parameters to the iVu Plus, including Command Channel changes to exposure time and gain, trigger mode, barcode compare string and/or mask, and Remote Teach sessions.

1. Write the number 102 as a 16-bit integer into the Command ID register.
2. Toggle the Command bit from 0 to 1 (bit 15 in the Input Bits/Input Coil Bits register).
3. Wait for the Command ACK flag to go from 0 to 1 (bit 15 in the Input Bits ACK/Input Coil Bits ACK register).
4. Verify that the Execution Error flag is not set (i.e. value should be 0). This is bit 15 in the Output Bits/Status Coil Bits register. If the value is 1, read the Error Code register for more information.
5. Task Complete. Toggle the Command bit back to 0 (bit 15 in the Input Bits/Input Coil Bits register).

8 Debugging Inspections

8.1 iVu Emulator

The iVu Emulator is a Windows application that allows you to operate in a Windows environment exactly as you would on the iVu Series sensor itself. In general, the Emulator is an inspection debugging tool where you can:

1. Import stored inspections and configuration from an iVu Plus TG sensor.
2. Modify inspection parameters on the emulator.
3. Restore the updated configuration back to the sensor.

8.2 How to Round-Trip Debug Using the Emulator

The iVu Emulator is a Windows application that allows you to operate in a Windows environment exactly as you would on the sensor itself. In general, the Emulator is an inspection debugging tool: you can import stored inspections and configuration from an iVu sensor, then modify its parameters on the emulator, and restore the updated configuration back to the sensor. When you install the iVu Emulator, by default, it is installed in the following folder:

C:\Program Files\Banner Engineering\iVu Series

You can run the Emulator from this folder, but you will need to move files between the USB drive and PC. To avoid moving files, you can copy the Emulator executable to the USB drive, and run the Emulator directly from the USB drive.

This "how-to" describes the procedures for doing round-trip debugging either using the iVu Emulator installed on a PC or using it directly from the USB Thumb Drive.



NOTE: This document refers to saving configuration and inspection logs in folders based on the sensor name. If you have not yet named the sensor, then folders will be named using the first 8-characters of the sensor serial number.

8.2.1 How to Debug Using the Emulator from a PC

1. Plug a USB Thumb Drive into the sensor.
2. Save Inspection Logs to the Thumb Drive.
 - a. On the Main Menu > Inspection Logs > View Logs screen, click the Save icon to save the inspection logs.
 - b. When prompted, select Yes to save sensor configuration along with the Inspection Logs. The location of these files on the USB Thumb Drive will be displayed after the operation is completed. The Inspection Logs are saved in <USB>:\BANNER\<SENSOR_NAME>\InspLog and the sensor configuration is saved in <USB>:\BANNER\<SENSOR_NAME>. For example, if the sensor name is myName:
 - Configuration File (CONFIG.CFG) path: <USB>:\BANNER\myName
 - Inspection Logs path: <USB>:\BANNER\myName\InspLog



NOTE: If the sensor has no name, then the folder is the first 8-characters of the serial number.

3. Remove the USB drive from the sensor and insert it into an available USB port on a Windows PC that has the iVu Emulator installed.



Important: Make sure the iVu Emulator is NOT running before going to the next step.

4. Copy the Sensor Configuration from the USB Thumb Drive to the folder where the Emulator is installed on the PC. For example, if the sensor name is myName and the iVu Emulator is installed in the default location on the PC, copy the file <USB>:\BANNER\myName\CONFIG.CFG to C:\Program Files\Banner Engineering\iVu Series.
5. Copy the Inspection Logs from the USB Thumb Drive (for example, <USB>:\BANNER\myName\InspLog) to the InspLog folder on the PC (for example, C:\Program Files\Banner Engineering\iVu Series\InspLogs).
6. Start the emulator.
7. Set the Trigger option to Internal—
 - a. Go to Main Menu > Imager > Trigger, and select Internal.
 - b. Set the Trigger Interval as desired.

The iVu Emulator will run with the saved configuration from Step 6 using the saved Inspection Logs from Step 7 as images.

8. Make the desired adjustments.

9. Close the iVu Emulator program. All configuration changes will be saved to the CONFIG.CFG file.
10. Copy the sensor configuration (that is, CONFIG.CFG) from the PC working directory to the USB Thumb Drive (for example <USB>:\BANNER\myName\CONFIG.CFG).
11. Remove the USB Thumb Drive from the PC, and connect to the sensor.
12. Restore the configuration to the sensor.
 - a. Go to Main Menu > System > Configuration > Load Configuration.
 - b. Select the Configuration to restore.
 - c. Click the Load button to start the restore sensor configuration.

You will need to reboot the sensor when the restore is complete.

8.2.2 How to Debug Using the Emulator from the USB Flash Drive

1. Plug a USB Thumb Drive into the sensor.
2. Save Inspection Logs to the sensor.
 - a. On the Main Menu > Inspection Logs > View Logs screen, click the Save icon to save the inspection logs.
 - b. When prompted, select Yes to save sensor configuration along with the Inspection Logs. The location of these files on the USB Thumb Drive will be displayed after the operation is completed—the Inspection Logs are saved in <USB>:\BANNER\<<SENSOR_NAME>\InspLog and the sensor configuration is saved in <USB>:\BANNER\<<SENSOR_NAME>. For example, if the sensor name is myName:
 - Configuration File (CONFIG.CFG) path: <USB>:\BANNER\myName
 - Inspection Logs path: <USB>:\BANNER\myName\InspLog



NOTE: If the sensor has no name, the folder name is the first 8-characters of the serial number.

3. Remove the USB drive from the sensor and insert it into an available USB port on a Windows PC that has the iVu Emulator installed.
4. Copy the iVuEmulator.exe program file to the USB Thumb Drive in the same location as the CONFIG.CFG file (for example, <USB>:\BANNER\myName).
5. Launch the <USB>:\BANNER\myName\iVuEmulator.exe program.
6. Set the Trigger option to Internal—
 - a. Go to Main Menu > Imager > Trigger, and select Internal.
 - b. Set the Trigger Interval as desired.

The iVu Emulator will run with the saved configuration using the saved Inspection Logs as images.

7. Make the desired adjustments.
8. Close the iVu Emulator program. All configuration changes will be saved to the CONFIG.CFG file.
9. Remove the USB Thumb Drive from the PC, and connect to the sensor.
10. Restore the configuration to the sensor.
 - a. Go to Main Menu > System > Configuration > Load Configuration.
 - b. Select the Configuration to restore.
 - c. Click the Load button to start the restore sensor configuration.

You will need to reboot the sensor when the restore is complete.

9 Updating the Sensor

9.1 Update Process

Banner Engineering may release new versions of the sensor firmware in the future. New firmware releases can be downloaded from Banner's website or can be obtained by ordering the latest Product CD. The following steps will guide you through the process of updating the iVu firmware.

Step 1: Copy firmware of desired product to USB Thumb Drive.

1. Launch the iVu Series software

From Product CD:

- Place the latest Product CD into your CD ROM drive. The iVu Series Software will automatically start.
- If your computer is not set for Auto-Play, you may start the iVu Series Software by browsing to the CD drive from My Computer screen and double-clicking on 'iVuSeries.exe'.

From Banner Website:

- Visit Banner's Website: <http://www.bannerengineering.com>
- Browse to Vision Products page and select the iVu product you are using.
- Click on the Software tab to view software releases.
- Determine which version you want to download (Current Version recommended, for example "iVu Series Software Version 2010R4").
- Click on the circular Download button. This will initiate the download process. Depending on your browser settings, you may be asked to confirm or provide a location to save the file. Choose to download on your desktop. Note the file name.
- Double-click the file to start extracting the files and run the iVu Series Software.

2. Select the product you are using and browse to Firmware Update page.

3. Click on 'Run Firmware Update Wizard' and program will start.

4. Follow on-screen instructions. Clicking on 'Copy firmware to USB' will copy the selected firmware to the USB Thumb Drive.

Step 2: Install firmware on iVu

1. Remove the USB Thumb Drive from the PC, and plug it into the sensor.

2. On the sensor, select System -> Firmware Update. The name of the firmware file you copied on the USB Thumb Drive will be displayed.

3. Choose correct file and click on the 'Load' button.

4. Follow the steps on the screen to update the firmware.

9.2 How to Set or Modify a Device Name

You can set a Device Name for your iVu Series sensor or modify an existing name on the sensor using the software keypad. You can also change the device name this using the iVu Emulator as described below.



NOTE: If you are in a language other than English, you cannot modify the device name using the software keypad. Use the procedure described below.



NOTE: If you have not set the device name previously, then folders will be named using the first 8-characters of the device serial number.

1. Plug a USB Thumb Drive into the device.
2. Save Device Configuration to the USB Thumb Drive (Main Menu > System > Configuration > Save to USB). The location of these files on the USB Thumb Drive will be displayed after the operation is complete—the device configuration is saved in <USB>:\BANNER\<DEVICE_NAME>. For example, if the device name is myName:, the path will be <USB>:\BANNER\myName).
3. Remove the USB drive from the device and insert it into an available USB drive on a Windows PC.
4. If running the Emulator from the USB, launch the iVuEmulator.exe program. If running the Emulator installed on a PC, make sure the Emulator is not running, and copy the Device Configuration from the USB Thumb Drive to the folder where the Emulator is installed on the PC. For example, if the device name is myName and the iVu Emulator

is installed in the default location on the PC, copy the file <USB>:\BANNER\myName\CONFIG.CFG to C:\Program Files\Banner Engineering\iVu Series.

5. Launch the iVuEmulator.exe program.
6. Go to the Information screen (Main Menu > System > Information).
7. Click the white box next to the Device Name label, and enter the desired Device Name.
8. Click the Back button on the lower-left corner of the screen to save the Device Name.
9. Close the Emulator program and the Device Name will be saved to the CONFIG.CFG file.
10. If running the Emulator on the PC, copy the CONFIG.CFG file back to the original folder on the USB drive—<USB>:\BANNER\<DEVICE_NAME> (for example <USB>:\BANNER\myName).



NOTE: The device will look in the original folder (for example, myName) for the CONFIG.CFG file.

11. Remove the USB Thumb Drive from the PC, and connect to the device.
12. Restore the configuration to the device.
 - a. Go to Main Menu > System > Configuration > Load from USB.
 - b. Select the Configuration to restore.
 - c. Click the Load button to start the restore device configuration.



NOTE: Once the new device name is restored in the device, all files saved to USB will now reside in the folder corresponding to the new device name.

You will need to reboot the device when the restore is complete.



NOTE: If a Device Configuration from one device is loaded onto another device, the Device Name from the Device Configuration will not be stored in the device.

9.3 How to Reset the Sensor Password

If you forget the password for your sensor, you can remove the current password using a reset key that is generated by the Password Reset Utility, which is located on the Product CD. The following steps will guide you through the specific steps to reset the password:

1. On your iVu Series sensor, click the Forgot? button located on the bottom of the Enter Current Password screen.
2. Write down the 6-digit Device Key.
3. On a Windows PC, insert the iVu product CD into the CD ROM drive.
4. From the product CD menu (started upon inserting the CD), launch the Password Reset Utility.
5. Enter the Device Key into the text box in the Utility—identified as Step 1 in the Password Reset Utility.
6. Click the Generate Reset Key button.
7. Write down the four-digit Password Reset Key—identified as Step 2 in the Password Reset Utility.
8. On the iVu Series sensor, check the Next button on the Password Reset screen.
9. Enter the 4-digit reset key on the Enter Reset Key screen.
10. Click Apply.

The password is now cleared.

9.4 How to Use Bitmap Image Files with the iVu Emulator

You can use bitmap (.bmp) image files with the iVu Emulator for developing and simulating iVu inspections. The iVu Emulator only accepts image files in .bmp format. If you have other image file formats, use an image viewer/editor program, such as PhotoShop, Gimp, or Paint, to convert the files to 8-bit grayscale .bmp format.



NOTE: Images smaller than 640 × 480 will be black-filled starting in the upper-right. Images larger than 640 × 480 will be cropped starting in the upper-left.

1. Copy the .bmp files into the InspLog folder in the iVu Emulator install folder.

For example, copy .bmp files into the C:\Program Files\Banner Engineering\iVu Series\InspLog folder.



NOTE: Remove any existing .bmp or Log files in that folder to avoid confusion because the Emulator automatically runs all .bmp/Log files sequentially according to filename.

2. Launch the iVu Emulator program.
3. Select Internal Trigger on the Trigger Selection screen (Main Menu > Image > Trigger) and select Internal.
4. Set the Trigger Interval as desired.

The iVu Emulator will be running using the .bmp files from Step 1.



NOTE: Banner does not recommend setting up inspections using these 8-bit grayscale images because you will always end up modifying the configuration after loading it on the sensor on the line. A better choice would be to set up the inspection on the emulator using Inspection Logs from the sensor.

10 LED Indicator Troubleshooting

In normal operation, the Power LED is steady green, and the Pass/Fail is green or red depending on the triggered inspection. The Ethernet I/O LED will be lit or off depending on connection status.



1	Power LED	Green: Power Red: Error
2	Pass/Fail LED	Green: Pass Red: Fail
3	Ethernet I/O LED	Green: Connected No Light: Disconnected

The iVu also indicates abnormal conditions as described below.

10.1 Errors

Problem Indicator	Solution
The Pass/Fail LED is blinking green a number of times, separated by an LED red blink, and the sensor repeats this pattern over and over. This indicates that no inspections are occurring.	Reboot the sensor.
The Power LED is lit steady red. These type of errors are reported in the System log and appear highlighted in red.	Do the following: <ol style="list-style-type: none"> 1. Look in the System Log to see the error. 2. Clear the LED; that is, go to the Main Menu > Logs > System Logs and press the Clear System Error button at the bottom of the screen (a sensor reboot is not required). 3. If the error occurs again, you can try rebooting the sensor to see if that fixes the problem. If the problem persists, contact Banner customer support.

10.2 Warnings

Warnings are atypical conditions that the sensor detects and fixes. Warning are highlighted in yellow in the System Log, and can typically be ignored.

11 Product Support and Maintenance

This section provides general Banner resources and specific documentation for installers and operators of this iVu Plus TG Vision Sensor.



WARNING: Not To Be Used for Personnel Protection

Never use this device as a sensing device for personnel protection. Doing so could lead to serious injury or death. This device does not include the self-checking redundant circuitry necessary to allow its use in personnel safety applications. A sensor failure or malfunction can cause either an energized or de-energized sensor output condition.

11.1 Product Support

Banner provides the following resources for quickly setting up and operating the device.

Documentation

Online Help

When setting up or monitoring inspections using the iVu sensor's integrated display, you can get online help on any screen by clicking the Help icon in the upper-right of the screen.

PDF Documentation

The product documentation is available in a convenient printable format (PDF) on the installation CD or at www.bannerengineering.com.

Banner Website

The most current product information, documentation, and software updates are available on the Banner website: www.bannerengineering.com.

Warranty Service

Contact Banner Engineering for troubleshooting of this device. Do not attempt any repairs to this Banner device; it contains no field-replaceable components. If the device or a device component is determined to be defective by a Banner Applications Engineer, they will advise you of Banner's RMA (Return Merchandise Authorization) procedure.



Important: If instructed to return the device, pack it with care. Damage that occurs in return shipping is not covered by warranty.

Factory Support

To help Banner better assist you, be ready to provide the following information:

- iVu firmware version (to find the version number, click Main Menu > System > Sensor Information)
- Device Model Number and Date Code, which are found on the bottom of the device.
- Exact wording of any messages that appeared on your screen
- A description of what you were doing and what happened
- A description of how you tried to solve the problem
- Error Codes (see [LED Indicator Troubleshooting](#) on page 157)

11.2 Maintenance

Maintenance tasks include keeping the hardware free of dust and dirt and possibly updating the iVu firmware as new versions become available.

Cleaning the Sensor

Regularly remove any dust or dirt from the device using a soft cloth. If needed, slightly dampen the cloth with a weak solution of neutral detergent. Avoid getting dirt on the imager (the area behind the lens). If the imager is dirty, use anti-static compressed air to blow off the dust.

Updating the iVu firmware

The current version of iVu firmware is available for download from the Banner website. See the Banner Website for the firmware download link.

11.3 Banner Engineering Corp Limited Warranty

Banner Engineering Corp. warrants its products to be free from defects in material and workmanship for one year following the date of shipment. Banner Engineering Corp. will repair or replace, free of charge, any product of its manufacture which, at the time it is returned to the factory, is found to have been defective during the warranty period. This warranty does not cover damage or liability for misuse, abuse, or the improper application or installation of the Banner product.

THIS LIMITED WARRANTY IS EXCLUSIVE AND IN LIEU OF ALL OTHER WARRANTIES WHETHER EXPRESS OR IMPLIED (INCLUDING, WITHOUT LIMITATION, ANY WARRANTY OF MERCHANTABILITY OR FITNESS FOR A PARTICULAR PURPOSE), AND WHETHER ARISING UNDER COURSE OF PERFORMANCE, COURSE OF DEALING OR TRADE USAGE.

This Warranty is exclusive and limited to repair or, at the discretion of Banner Engineering Corp., replacement. IN NO EVENT SHALL BANNER ENGINEERING CORP. BE LIABLE TO BUYER OR ANY OTHER PERSON OR ENTITY FOR ANY EXTRA COSTS, EXPENSES, LOSSES, LOSS OF PROFITS, OR ANY INCIDENTAL, CONSEQUENTIAL OR SPECIAL DAMAGES RESULTING FROM ANY PRODUCT DEFECT OR FROM THE USE OR INABILITY TO USE THE PRODUCT, WHETHER ARISING IN CONTRACT OR WARRANTY, STATUTE, TORT, STRICT LIABILITY, NEGLIGENCE, OR OTHERWISE.

Banner Engineering Corp. reserves the right to change, modify or improve the design of the product without assuming any obligations or liabilities relating to any product previously manufactured by Banner Engineering Corp.

Index

A

Advanced 49
area parameters
 area range 24, 60
 intensity range 24
area range 24, 60
area sensor 23
area_history command group 93
area_result command group 92
auto exposure 30

B

blemish sensor 24
blemish_history command group 93
blemish_result command group 93

C

command channel
 image export 75
command channel log 83
command channel sample
 application 74
command group
 area_history 93
 area_result 92
 blemish_history 93
 blemish_result 93, 94
 history 91
 info 88
 inspection 92
 match_history 94
 productchange 91
 sort_history 95
 sort_result 95
 status 89
 system 89
 trigger 90
communication channel
 command channel 16, 73
 data export 16, 73
 image export 16, 73
 Industrial Ethernet 16, 73
Communication Logs 52
communications channels 16, 73
Configuration menu 35

D

data export 16, 73
data export log 83
data export sample application 75
debugging 152
Display Settings menu 49

E

emulator 152
Ethernet 16, 73
ethernet communications 76
exposure 31
external strobe 33

F

fail hold time 49

field of view 34
firmware update 50
focus number 32

G

gain 31

H

history command group 91
home screen 18

I

image export 16, 73, 75
image export sample application 76
imager
 auto exposure 30
 exposure 31
 gain 31
 trigger 31
imager menu 30
Industrial Ethernet 16, 73
info command group 88
Information 36
inspection command group 92
Inspection Logs 50
inspection menu
 properties menu 28
Inspection Menu
 Sort Menu 26
inspection name 28
intensity range 24
internal strobe 33
iVu emulator 152

L

LCD Timeout 49
Load from USB 36
lock sensor 36
logs
 command channel 83
 data export 83
 communication 52
 inspection 50
 system 52

M

match parameters
 percent match 26, 27, 66
 rotation range 26, 67
 timeout 26, 27
match sensor 25
match_history command group 94
match_result command group 94
maximum pass count 24–26, 61,
 68

menu

 Display Settings 49
 Configuration 35

Mode 35

 System 35

minimum pass count 24–26, 61, 68

Mode menu 35

motion parameters

 area range 24, 60

 intensity range 24

 motion settings 27

 number of edges 28, 71

 rotation 28, 71

 sensitivity 28, 71

motion settings 27

N

number of edges 28, 71

P

pass count parameter 24–26, 61,
 68

percent match 26, 27, 66

productchange command group 91

properties

 inspection name 28

properties menu 28

R

rotation parameter 28, 71

rotation range 26, 27, 67

RS-232 16, 73

S

sample application
 command channel 74
 data export 75
 image export 76

Save to USB 36

saved patterns 27

sensitivity 28, 71

sensor display 18

sort menu

 saved patterns 27

Sort Menu 26

sort parameters

 rotation range 27

 timeout 26, 27

sort_history command group 95

sort_result command group 95

status command group 89

strobe

 external 33

 internal 33

system command group 89

System Logs 52

System menu 35

T

timeout 26, 27

Touchscreen Calibration 49

trigger 31

trigger command group 90
U
USB

loading from 36
saving to 36