

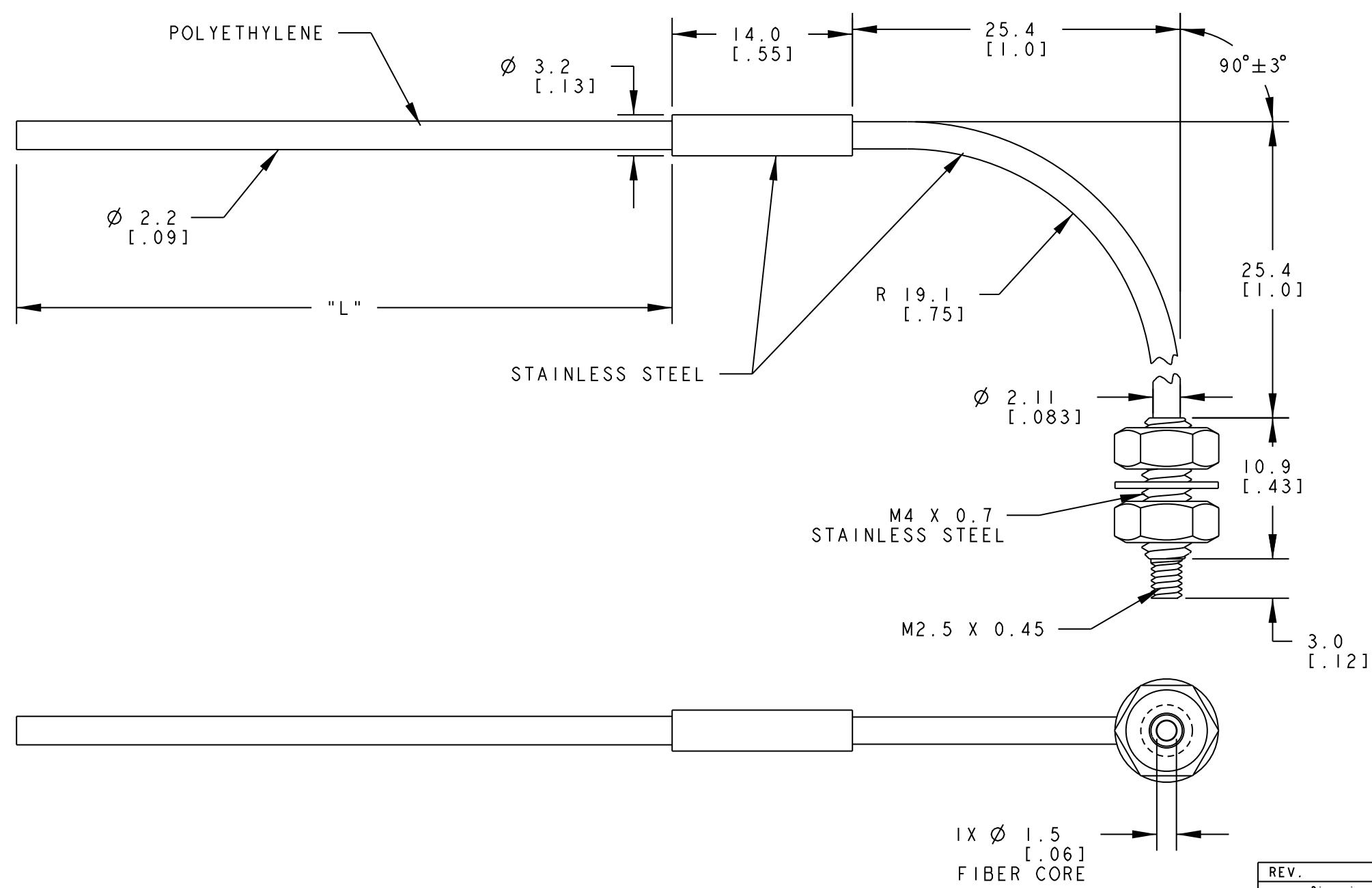

8 7 6 5 4 3 2 1

REVISION HISTORY			
REV	DESCRIPTION	DATE	APPROVED



MODEL NO.	"L"	P/N
PIAT630U	10000 [394]	72812
PIAT660U	18288 [720]	61172
PIAT615U	5000 [197]	56141
PIAT6100U	30480 [1200]	56101
PIAT66U	2000 [79]	42885

NOTE:  
 1. HARDENED STAINLESS STEEL TUBING ON ANGLED END IS NOT BENDABLE.

REV.	DESCRIPTION	DATE	INITIAL
Dimensions are Millimeters [inches] TOLERANCES (Unless Otherwise Specified) X = ±2.5mm X.X = ±0.25 X.XX = ±0.12mm [X.X = ±.1"] [.XX = ±.01"] [.XXX = ±.005"] ANGLE = ±3° *L = 40mm/Meter [.5"/Foot]		 BANNER ENGINEERING Corp. 9717 10th Ave. North Minneapolis, MN 55441 Tel # 763-544-3164 Fax # 763-544-3573 www.bannerengineering.com	
This drawing is the property of BANNER ENGINEERING Corp. and is proprietary in general and in detail. Its contents shall not be revealed to outside parties without the written consent of BANNER.			
PIAT66U		PLASTIC FIBEROPTIC ASSEMBLY & MOD'S	
10-17-96	I OF I	42885	-

8 7 6 5 4 3 2 1