



# INSTALLATION INSTRUCTIONS

## MLS10, MLS11, MLS14, MLS16, MLS30, MLS31 MonoLine® Joiner Supports

**SAVE THESE INSTRUCTIONS and refer to them when making any additions or changes to the track configuration.**

### IMPORTANT SAFETY INSTRUCTIONS

1. Read all instructions prior to installing this product.
2. Disconnect electrical power before adding to or changing the configuration of the track.
3. Do not install this track in damp or wet locations.
4. Do not install any part of track system less than 5 feet above floor.
5. Do not attempt to energize anything other than lighting fixtures and fittings intended for use on MonoLine track.

### WARNING

BE SURE TO TURN OFF POWER TO THE JUNCTION BOX BEFORE INSTALLATION.

#### MLS10 Conducting Straight Joiner Stem Support

#### MLS11 Non-Conducting Straight Joiner Stem Support

#### MLS14 "L" Joiner Stem Support

#### MLS16 "T" Joiner Stem Support

- ① Layout track design and mark position of each ceiling support. Evenly space supports in desired pattern.  
IMPORTANT: Space supports no more than 3' apart (see CAUTION note below).  
Unscrew mounting flange from top finial.
- ② Drill hole in ceiling at desired anchor location.
- ③ Insert enclosed anchor plug into drilled hole.
- ④ Position mounting flange over anchor plug, insert enclosed screw and secure flange to ceiling.
- ⑤ Screw joiner assembly onto flange. Loosen set screws in finial or joiner as needed to properly orient joiner.
- ⑥ Tighten set screws.
- ⑦ Follow track insertion instructions on page 2.
- ⑧
- ⑨

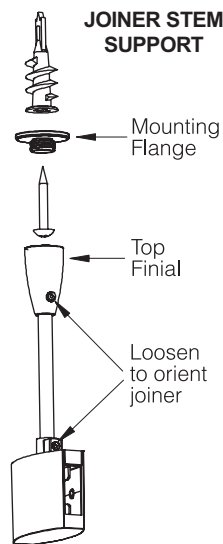

#### MLS30 Straight Joiner Cable Support MLS31 Non-Conducting Straight Joiner Cable Support

- ① Layout track design and mark position of each ceiling support. Evenly space supports in desired pattern.  
IMPORTANT: Space supports no more than 3' apart (see CAUTION note below).  
Unscrew mounting flange from top finial.
- ② Drill hole in ceiling at desired anchor location.
- ③ Insert enclosed anchor plug into drilled hole.
- ④ Position mounting flange over anchor plug, insert enclosed screw and secure flange to ceiling.
- ⑤ Screw top finial with cable onto flange. Loosen set screw in lower finial.
- ⑥ Raise or lower joiner assembly to desired position along cable.
- ⑦ Retighten set screw.
- ⑧ Cut off cable as close as possible to lower finial.
- ⑨ Follow track insertion instructions on page 2.
- ⑩
- ⑪

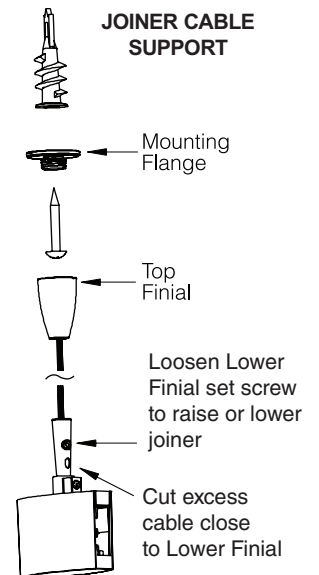

**CAUTION:**  
When installing SP253 LED Directional Fixtures on MonoLine systems:

1. Supports should be spaced no more than 2' apart.
2. The use of MLS3 or MLS30 or MLS31 Cable Supports is not recommended.



JUNO LIGHTING GROUP  
an AcuityBrands company



# INSTALLATION INSTRUCTIONS

## MLJ1, MLJ2, MLJ3, MLJ4, MLJ6 MonoLine® Joiners

**SAVE THESE INSTRUCTIONS and refer to them when making any additions or changes to the track configuration.**

### Track Insertion

**MLJ1 Conducting Straight Joiner**

**MLJ2 Non-Conducting Straight Joiner**

**MLJ3 Flexible Joiner**

**MLJ4 "L" Adjustable Joiner**

**MLJ6 "T" Joiner**

- ① Make sure main power to system is OFF.
- ② Note polarity feature at bottom of opening in Joiner.
- ③ Note which side of track has a groove to accept the polarity feature. The grooved side of the track should be facing down. Insert track fully into Joiner aligning polarity feature with groove.
- ④ Tighten all set screws securely with the hex wrench provided.
- ⑤ Tighten the inner hex screw securely with the provided hex wrench after the adjustment. (For MLJ6 and MLJ4)
- ⑥

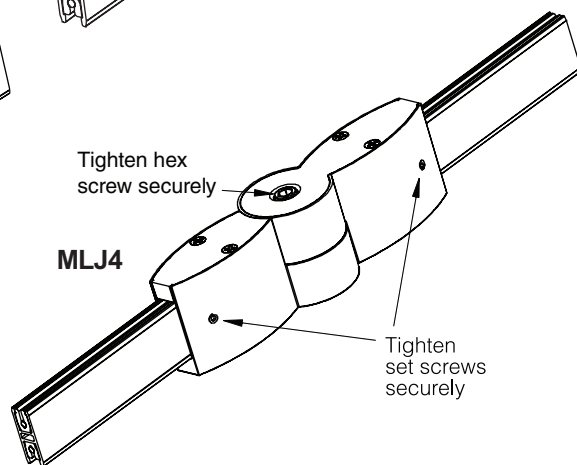
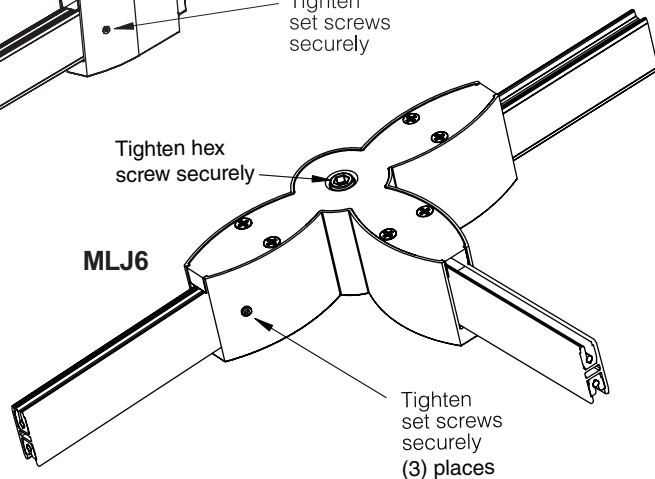
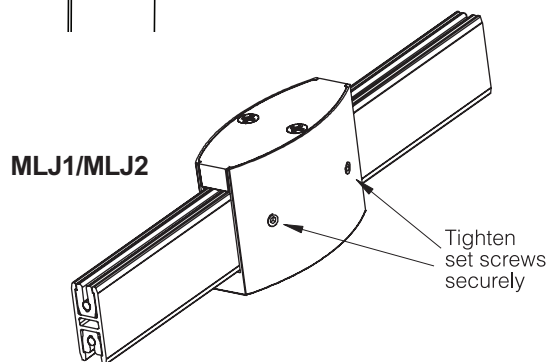
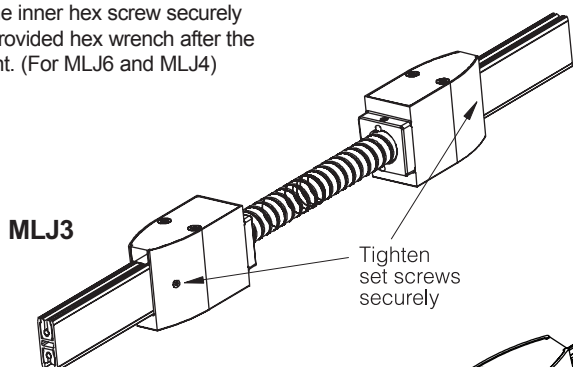
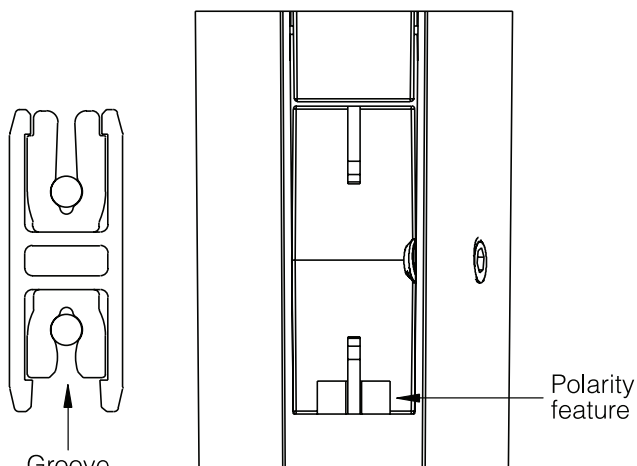

### WARRANTY

Juno Lighting Group warrants that its products are free from defects in material and workmanship for one year from date of purchase, two years from date of purchase for Energy Star® rated fixtures. Juno Lighting Group's obligation is expressly limited to repair or replacement, without charge, at Juno Lighting Group's factory after prior written return authorization has been granted. This warranty shall not apply to products which have been altered or repaired outside of Juno Lighting Group's factory. This warranty is in lieu of all other warranties, expressed or implied, and without limiting the generality of the foregoing phrase, excludes any implied warranty of merchantability. Also, there are no warranties which extend beyond the description of the product on the company's literature setting forth terms of sale.

**Product Services Phone (888) 387-2212**

1300 South Wolf Road • Des Plaines, IL 60018 • [www.junolightinggroup.com](http://www.junolightinggroup.com)



JUNO LIGHTING GROUP  
an AcuityBrands company