



SERVICE PARTS LIST

BULLETIN NO.
54-26-2700

SPECIFY CATALOG NO. AND SERIAL NO. WHEN ORDERING PARTS		REVISED BULLETIN	DATE
18 Volt 3/8" Square Impact Driver			Aug. 2008
CATALOG NO.	2651-20	STARTING SERIAL NO.	B77A
		WIRING INSTRUCTION SEE REVERSE SIDE	

EXAMPLE:
00 0 Component Parts (Small #)
Are Included When Ordering
The Assembly (Large #).

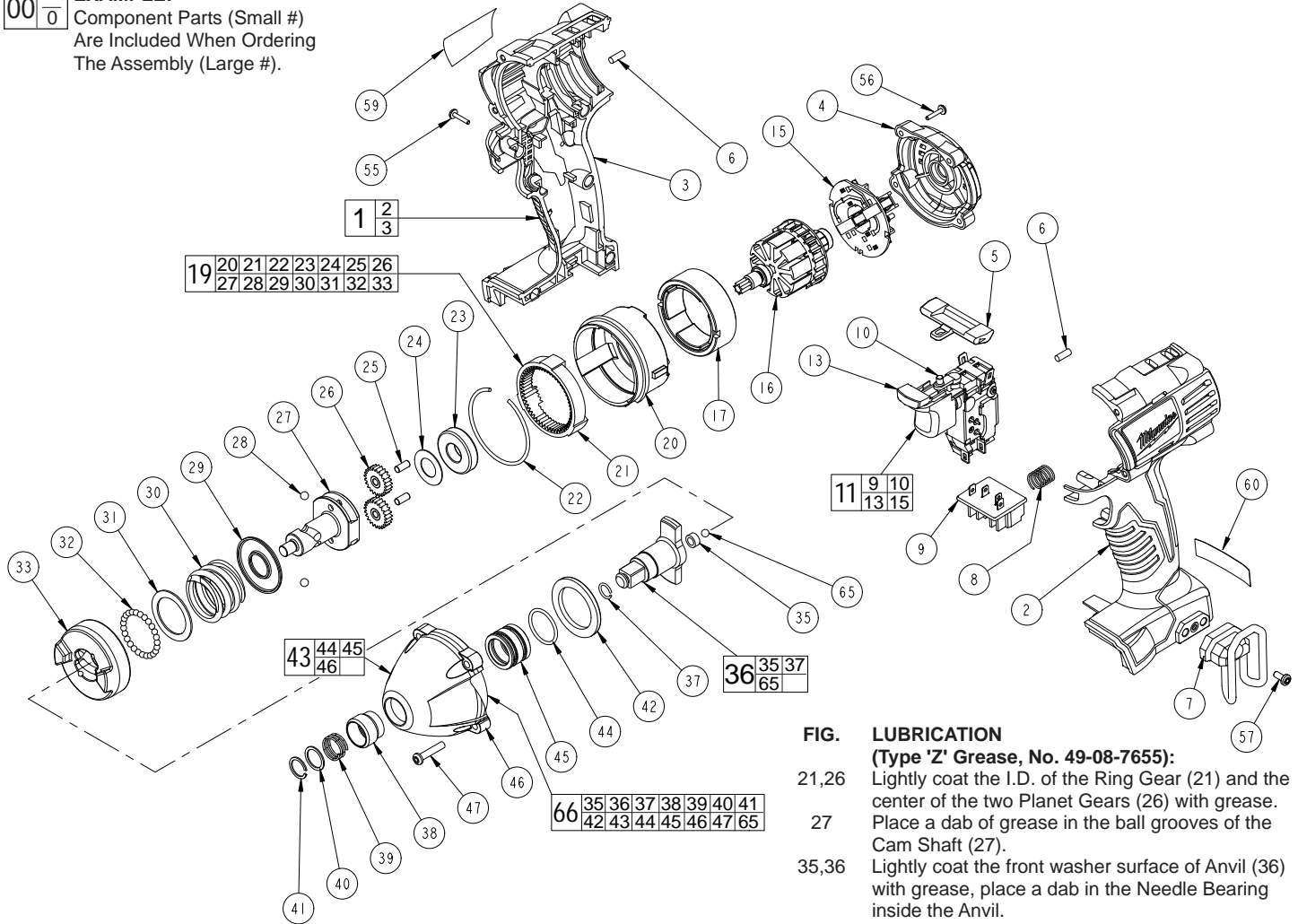

FIG. LUBRICATION

(Type 'Z' Grease, No. 49-08-7655):

- 21,26 Lightly coat the I.D. of the Ring Gear (21) and the center of the two Planet Gears (26) with grease.
- 27 Place a dab of grease in the ball grooves of the Cam Shaft (27).
- 35,36 Lightly coat the front washer surface of Anvil (36) with grease, place a dab in the Needle Bearing inside the Anvil.
- 45 Coat outside grooves of Bushing (45) with grease.

FIG.	PART NO.	DESCRIPTION OF PART	NO. REQ.
1	31-44-2430	Handle Assembly	(1)
2	-----	Left Handle Half	(1)
3	-----	Right Handle Half	(1)
4	42-52-0062	End Cap	(1)
5	45-24-0300	Forward / Reverse Shuttle	(1)
6	45-30-0250	Rubber Slug	(8)
7	42-70-5150	Belt Hook	(1)
8	40-50-1090	Spring	(1)
9	-----	Contact Block	(1)
10	-----	Switch	(1)
11	23-66-0426	Switch/Brush Card Assembly	(1)
13	-----	LED Assembly	(1)
15	-----	Brush Card Assembly	(1)
16	16-01-3010	Service Armature Assembly	(1)
17	18-01-3010	Service Field	(1)
19	14-30-0920	Gear Box Assembly	(1)
20	44-66-1600	Rear Case	(1)
21	32-65-0230	Ring Gear	(1)
22	44-90-0950	Retaining Ring	(1)
23	02-04-1890	Ball Bearing	(1)
24	45-88-1970	Washer	(1)
25	44-60-1950	Pin	(2)
26	32-62-0375	Planet Gear	(2)
27	42-50-0450	Cam Shaft	(1)
28	02-02-0180	3/16" Steel Ball	(2)
29	45-88-2050	Washer	(1)
30	40-50-1105	Compression Spring	(1)
31	45-88-2010	Washer	(1)

FIG.	PART NO.	DESCRIPTION OF PART	NO. REQ.
32	02-02-0165	3.0mm Steel Ball	(30)
33	44-82-0800	Hammer	(1)
35	-----	Needle Bearing	(1)
36	42-06-0600	3/8" Square Drive Anvil Assembly	(1)
37	34-60-1030	Hog Ring	(1)
38	45-22-0825	Sleeve	(1)
39	40-50-1470	Spring	(1)
40	45-88-1880	Washer	(1)
41	34-60-0725	Retaining Ring	(1)
42	45-88-2025	Front Washer	(1)
43	28-50-0900	Front Case Sub-Assembly	(1)
44	-----	Retaining Ring	(1)
45	-----	Bushing	(1)
46	-----	Front Case	(1)
47	06-82-7010	8-18 x 24 Pan Hd. Screw	(4)
55	06-82-6350	M3 Pan Hd. T-10 Screw	(7)
56	06-82-7336	M3 Pan Hd. T-10 Screw	(4)
57	06-82-5275	6-32 x 5/16" Slit. Pan Hd. T-15 Screw	(1)
59	12-20-2650	Service Nameplate Kit	(1)
60	10-20-2695	Warning Label	(1)
65	-----	5mm Steel Ball	(1)
66	14-30-0950	Front Case Assembly	(1)
	42-55-2650	Carrying Case (Not Shown)	(1)

BRUSH CARD ASSEMBLY

FIELD

AS AN AID TO REASSEMBLY, TAKE NOTICE OF WIRE ROUTING AND POSITION IN WIRE GUIDES AND TRAPS WHILE DISMANTLING TOOL

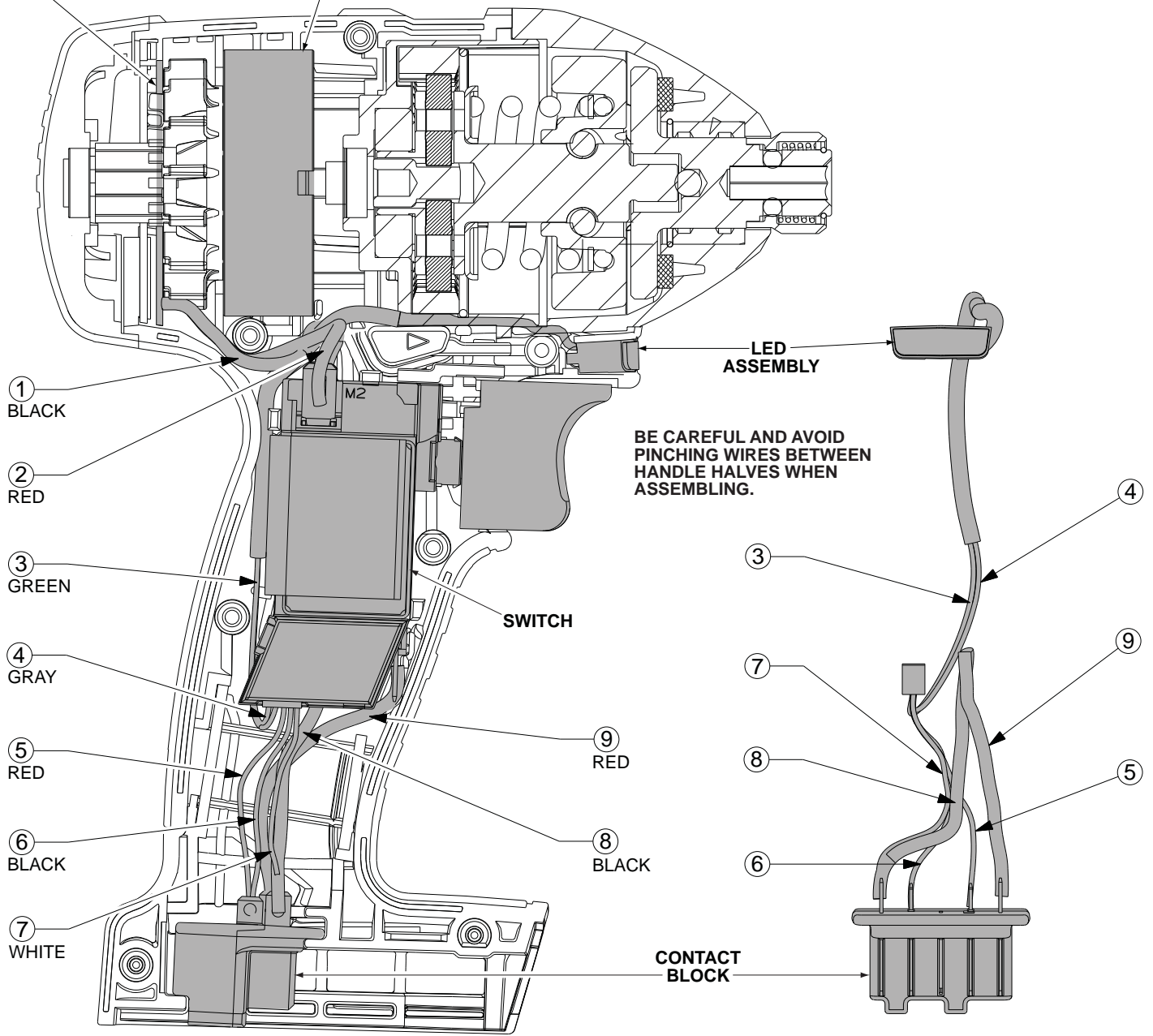

WIRING SPECIFICATIONS

Wire No.	Wire Color	Origin or Gauge	Length	Terminals, Connectors and 1 or 2 End Wire Preparation
1	Black	----	----	Component of the Switch/Brush Card Assembly.
2	Red	----	----	Component of the Switch/Brush Card Assembly.
3	Green	----	----	Component of the Switch/Brush Card Assembly.
4	Gray	----	----	Component of the Switch/Brush Card Assembly.
5	Red	----	----	Component of the Switch/Brush Card Assembly.
6	Black	----	----	Component of the Switch/Brush Card Assembly.
7	White	----	----	Component of the Switch/Brush Card Assembly.
8	Black	----	----	Component of the Switch/Brush Card Assembly.
9	Red	----	----	Component of the Switch/Brush Card Assembly.