

# Air-cooled standby generator systems 20 and 22 kW



EGSX200NSEA

## System overview

- Complete backup power system featuring a full line of Eaton automatic transfer switches and generators
- Exclusive national Eaton Certified Contractor Network (ECCN) contractors for installation, maintenance, and service
- Local sales expertise and round-the-clock telephone pre-/post-sales technical support



EGENX22A (includes EGENFASCIA)

**EATON**

*Powering Business Worldwide*

**Table 1. Generator features**

	<b>Features</b>	<b>Benefits</b>
Engine	<ul style="list-style-type: none"> <li>Overhead valve industrial engine design (OHVI)</li> <li>“Spiny-lok” cast iron cylinder walls</li> <li>Electronic ignition/spark advance</li> <li>Full pressure lubrication system</li> <li>Low oil pressure shutdown system</li> <li>High temperature shutdown</li> </ul>	<ul style="list-style-type: none"> <li>Maximizes engine “breathing” for increased fuel efficiency. Plateau-honed cylinder walls and plasma moly rings help engine run cooler, reducing oil consumption. Because heat is the primary cause of engine wear, the OHVI has a significantly longer life than competitive engines</li> <li>Rigid construction and added durability provide long engine life</li> <li>Assured smooth, quick start every time</li> <li>Superior lubrication to all vital bearings means better performance, less maintenance, and significantly longer engine life. Now featuring a 2-year/200-hour oil change interval</li> <li>Superior shutdown protection prevents catastrophic engine damage from low oil</li> <li>Prevents damage due to overheating</li> </ul>
Generator	<ul style="list-style-type: none"> <li>Revolving field</li> <li>Skewed stator and skewed rotor</li> <li>Displaced phase excitation</li> <li>Automatic voltage regulation</li> <li>UL® 2200 Listed</li> </ul>	<ul style="list-style-type: none"> <li>Allows for smaller, lightweight unit that operates 25% more efficiently than a revolving armature generator</li> <li>Produces a smooth output waveform for electronic equipment compatibility</li> <li>Maximizes motor starting capability</li> <li>Regulates the output voltage to ±2%, which prevents damaging voltage spikes</li> </ul>
New controller and controls	<ul style="list-style-type: none"> <li>Auto/manual/off membrane pad buttons</li> <li>Utility voltage sensing</li> <li>Utility interrupt delay</li> <li>Internationally recognized buttons</li> <li>Engine warm up</li> <li>Engine cool down</li> <li>Seven day exerciser</li> <li>Timed trickle battery charger</li> <li>Main line circuit breaker</li> <li>Electronic governor</li> <li>Covered/recessed fuse holder with USB port</li> <li>Smart battery charger</li> <li>Modern, innovative design</li> </ul>	<ul style="list-style-type: none"> <li>Selects the operating mode for easy, at-a-glance status indication</li> <li>Weather-resistant interface allows smooth programming and operations for the user</li> <li>Constantly monitors utility voltage, set points 60% dropout, and 80% pickup of standard voltage</li> <li>Prevents nuisance startups of the engine, adjustable 2 to 1500 seconds</li> <li>Ensures engine is ready to assume the load, set point approximately 5 seconds</li> <li>Allows engine to cool prior to shutdown, set point approximately 1 minute</li> <li>Operates engine to prevent oil seal drying and damage between power outages</li> <li>Maintains battery charge level to ensure starting</li> <li>Protects generator from overload</li> <li>Maintains constant 60 Hz frequency</li> <li>USB port allows programming updates for field adjustment vs. full replacement</li> </ul>
Unit	<ul style="list-style-type: none"> <li>Weather protective enclosure</li> <li>Enclosed critical grade muffler</li> <li>Small, compact, attractive</li> </ul>	<ul style="list-style-type: none"> <li>Ensures protection against nature’s elements. Hinged key locking roof panel for security. Lift-out front for easy access to all routine maintenance items. Electrostatically applied textured epoxy paint for added durability</li> <li>Quiet, critical grade muffler is mounted inside the unit to prevent injuries</li> <li>Makes for an easy, eye-appealing installation</li> <li>Complies with local dB noise levels</li> </ul>
Installation system	<ul style="list-style-type: none"> <li>1-foot flexible fuel line connector</li> <li>Composite mounting pad</li> </ul>	<ul style="list-style-type: none"> <li>Easy installation</li> </ul>
Warranty ①	<ul style="list-style-type: none"> <li>5-year limited warranty:                             <ul style="list-style-type: none"> <li>Years 1 and 2—limited comprehensive coverage on mileage, labor, and parts (warranty certification required)</li> <li>Year 3—limited comprehensive coverage on parts only</li> <li>Years 4 and 5—limited comprehensive coverage on engine (short block) and alternator (rotor and stator) parts only</li> </ul> </li> </ul>	

① For warranty details, refer to the “Eaton Air-Cooled Automatic Standby Generators” warranty statement.

**Table 2. Compatible automatic transfer switches ①**

	<b>Features</b>	<b>Benefits</b>
EGSU series featuring universal active load management	<ul style="list-style-type: none"> <li>• Truly active load management system</li> <li>• RTC-100 controller with built-in intelligence</li> <li>• Universal compatibility with any generator brand (single-phase, 240 V)</li> <li>• No programming necessary</li> <li>• Whole house surge included (catalog number: CHSPT2ULTRA)</li> <li>• 50 or 60 Hz</li> <li>• Current sensors (CTs) included</li> <li>• Built-in 7-, 14-, and 28-day plant exerciser</li> <li>• Load and no-load transfer</li> <li>• Meets NEC® Article 702.5 for optional standby backup power systems</li> <li>• UL 1008 Listed</li> </ul>	<ul style="list-style-type: none"> <li>• Actively balances electrical loads in the household, adjusting to homeowner's lifestyle</li> <li>• Compatible with any generator brand (single-phase, 240 V)</li> <li>• Complete home surge protector included to protect home electronics and appliances against surge events</li> <li>• Complete power monitoring for greater accuracy and load management: voltage, current, and frequency</li> <li>• Power monitoring system allows 100% use of power output rating in the generator</li> <li>• Contractor-friendly installation, requires fewer connections to the generator</li> <li>• Environmentally friendly: allows downsizing of generator resulting in decrease of greenhouse gas (GHG) emissions, and reduces gas consumption by 15% or more</li> </ul>
EGSX series featuring load shedding	<ul style="list-style-type: none"> <li>• Two sets of contacts for load shedding</li> <li>• Simplified, non-redundant relay-interface system</li> <li>• Terminal block termination; connections labeled to match generator connections</li> <li>• Three-point keyhole mounting system for quick, level installation</li> <li>• Optimal wire bending space</li> <li>• Commercial grade main breaker included</li> <li>• UL 1008 compliant</li> <li>• Meets NEC Article 702.5.A for optional standby backup power systems</li> </ul>	<ul style="list-style-type: none"> <li>• Easy, intuitive installation for labor savings</li> <li>• Compatible with Eaton generators and most standby generator brands</li> <li>• Smallest footprint in the industry (400 A model)</li> </ul>
Warranty ②	<ul style="list-style-type: none"> <li>• 1-year limited warranty from the date of installation or 18 months from the date of shipment, whichever occurs first</li> <li>• Extended and special warranties available:                             <ul style="list-style-type: none"> <li>• 24 months—2% of contract price</li> <li>• 30 months—3% of contract price</li> <li>• 36 months—4% of contract price</li> </ul> </li> </ul>	

① For selection information, visit our online green ATS interactive demo at <http://greenats.eaton.com>.

② For warranty details, refer to Eaton Selling Policy 25-000.

**Table 3. Automatic transfer switch specifications**

Amperes	Voltages	Number of poles	Service entrance	Number of circuits included ①	Frequency	Enclosure type	Contactor wire size ranges(s)	Number of cables per phase	Withstand current (rms) at 240 Vac	Most common generator sizes ②	Catalog number
<b>EGSU series</b>											
50	120/240	2	—	24	50/60	NEMA 3R	#14–#2/0	1	10,000	8, 11, 16 kW	<b>EGSU100L24RACA</b>
50	120/240	2	—	—	50/60	NEMA 3R	#14–#2/0	1	10,000	8, 11, 16 kW	<b>EGSU100ACA</b>
100	120/240	2	Y	—	50/60	NEMA 3R	#14–#2/0	1	25,000	8, 11, 16 kW	<b>EGSU100NSEACA</b>
100	120/240	2	Y	—	50/60	NEMA 3R	#4–300 kcmil	1	25,000	8, 11, 16 kW	<b>EGSU150NSEACA</b>
200	120/240	2	—	—	50/60	NEMA 3R	#4–300 kcmil	1	10,000	16, 20, 22 kW	<b>EGSU200ACA</b>
200	120/240	2	Y	—	50/60	NEMA 3R	#4–300 kcmil	1	25,000	16, 20, 22 kW	<b>EGSU200NSEACA</b>
200	120/240	2	Y	—	50/60	NEMA 3R	750 kcmil–2 / 300 kcmil–1/0	1/2	35,000	>22 kW	<b>EGSU400NSEACA</b>
<b>EGSX series</b>											
50	120/240	2	Y	12	50/60	NEMA 1	#14–#6	1	5000	8, 11 kW	<b>EGSX50L12</b>
50	120/240	2	—	12	50/60	NEMA 3R	#14–#6	1	5000	8, 11 kW	<b>EGSX50L12R</b>
100	120/240	2	—	—	50/60	NEMA 3R	#14–#2/0	1	10,000	8, 11, 16 kW	<b>EGSX100A</b>
100	120/240	2	Y	—	50/60	NEMA 3R	#14–#2/0	1	25,000	8, 11, 16 kW	<b>EGSX100NSEA</b>
100	120/240	2	—	24	50/60	NEMA 3R	#14–#2/0	1	10,000	8, 11, 16 kW	<b>EGSX100L24RA</b>
150	120/240	2	Y	—	50/60	NEMA 3R	#4–300 kcmil	1	25,000	16, 20, 22 kW	<b>EGSX150NSEA</b>
200	120/240	2	—	—	50/60	NEMA 3R	#4–300 kcmil	1	10,000	16, 20, 22 kW	<b>EGSX200A</b>
200	120/240	2	Y	—	50/60	NEMA 3R	#4–300 kcmil	1	25,000	16, 20, 22 kW	<b>EGSX200NSEA</b>
400	120/240	2	Y	—	50/60	NEMA 3R	750 kcmil–2 / 300 kcmil–1/0	1/2	35,000	>22 kW	<b>EGSX400NSEA</b>

① Uses CH type circuit breakers.

② For reference only. Generator size must be determined by actual load calculations.

**Table 4. Generator specifications**

	Catalog number	
	EGENX20A	EGENX22A
<b>Generator</b>		
Rated maximum continuous power capacity (LP)/(NG)	20,000/18,000 watts ①	22,000/19,500 watts ①
Enclosure	Aluminum	Aluminum
Rated voltage	120/240	120/240
Rated maximum continuous load current 240 V ②	83.3 LP / 75 NG	91.7 LP / 81.2 NG
Total harmonic distortion	Less than 5%	Less than 5%
Main line circuit breaker	90 A	100 A
Phase	Single	Single
Number of rotor poles	2	2
Rated AC frequency	60 Hz	60 Hz
Power factor	1	1
Battery requirement (not included)	Group 26R, 12 V and 525 cold-cranking amps minimum	Group 26R, 12 V and 525 cold-cranking amps minimum
Unit weight lbs (kg)	451 (204.6)	476 (216.0)
Dimensions in inches (mm) L x W x H	48.00 x 25.00 x 29.00 (1219.2 x 635.0 x 736.6)	48.00 x 25.00 x 29.00 (1219.2 x 635.0 x 736.6)
Sound output in dBA at 23 ft with generator operating at normal load	66	67
Sound output in dBA at 23 ft with generator in Quiet-Test™ low speed exercise mode	60	58
<b>Engine</b>		
Type of engine	OHVI V-TWIN	OHVI V-TWIN
Number of cylinders	2	2
Displacement	999 cc	999 cc
Cylinder block	Aluminum with cast iron sleeve	Aluminum with cast iron sleeve
Valve arrangement	Overhead valve	Overhead valve
Ignition system	Solid-state with magneto	Solid-state with magneto
Governor system	Electronic	Electronic
Compression ratio	9.5:1	9.5:1
Starter	12 Vdc	12 Vdc
Oil capacity including filter	Approximately 1.9 qts./1.8 L	Approximately 1.9 qts./1.8 L
Operating RPM	3,600	3,600
<b>Fuel consumption ③</b>		
Natural gas	ft <sup>3</sup> /hr (m <sup>3</sup> /hr):	
	1/2 load	205 (5.8)
	Full load	308 (8.72)
Liquid propane	ft <sup>3</sup> /hr (gal/hr) (liters/hr):	
	1/2 load	75.6 (2.08) (7.87)
	Full load	140 (3.85) (14.57)
		184 (5.21)
		281 (7.96)
		78.6 (2.16) (8.16)
		133.9 (3.68) (13.94)

① Suitable for “optional” standby backup power only, as indicated by NEC Article 702. Not suitable for legally required “emergency” life safety applications as required by NEC Article 700 and NFPA 110/99. All ratings in accordance with BS5514, ISO3046, and DIN6271. Maximum wattage and current are subject to and limited by such factors as fuel BTRU content, ambient temperature, altitude, engine power and condition. Maximum power decreases about 3.5% for each 1000 feet above sea level, and also will decrease about 1% for each 12 °C (10 °F) above 15.5 °C (60 °F).

② LP = Liquid propane  
NG = Natural gas

③ Gas pipe sizing is critical for the proper operation of the generator. Fuel pipe must be sized for full load. Required fuel pressure to generator fuel inlet at all load ranges—3.5 to 7 inches water column (7 to 13 mm mercury) for natural gas, 10 to 12 inches water column (19 to 22 mm mercury) for LP gas. For BTU content, multiply ft<sup>3</sup>/hr x 2500 (LP) or ft<sup>3</sup>/hr x 1000 (NG). For Megajoule content, multiply m<sup>3</sup>/hr x 93.15 (LP) or m<sup>3</sup>/hr x 37.26 (NG).

**Table 5. Generator controls**

<b>Features</b>	<b>Description</b>
Two-line plain text multilingual LCD display	Simple user interface for ease of operation
Mode buttons Auto Manual Off	Automatic start on utility failure. 7-day exerciser (7-, 14-, and 28-day exerciser when coupled with EGSU ATS) Start with starter control, unit stays on. If utility fails, transfer to load takes place Stops unit. Power is removed. Control and charger still operate
Ready to run/maintenance messages	Standard
Engine run hours indication	Standard
Programmable start delay between 2 and 1500 seconds	Standard (programmable by dealer only)
Utility voltage loss/return to utility adjustable	From 140 V to 171 V / 190 V to 216 V
Future set capable exerciser/exercise set error warning	Standard
Run/alarm/maintenance logs	50 events each
Engine start sequence	Cyclic cranking 16 seconds on, 7 rest (90 seconds maximum duration)
Starter lockout	Starter cannot re-engage unit 5 seconds after engine has stopped
Smart battery charger	Standard
Charger fault/missing AC warning	Standard
Low battery/battery problem protection and battery condition indication	Standard
Automatic voltage regulation with overvoltage and undervoltage protection	Standard
Underfrequency/overload/stepper overcurrent protection	Standard
Safety fused/fuse problem protection	Standard
Automatic low oil pressure/high oil temperature shutdown	Standard
Overcrank/overspeed at 72 Hz/RPM sense loss shutdown	Standard
High engine temperature shutdown	Standard
Internal fault/incorrect wiring protection	Standard
Common external fault capacity	Standard
Field-upgradable firmware	Standard

**Table 6. Compatible accessories and replacement parts—EGENX generators**

Description	Benefits/features	Catalog number
<b>Maintenance and general accessories</b>		
Cold weather kit	Includes battery and engine warmer. Built-in thermostats maintain battery and oil in optimal temperatures for engine performance. Recommended in areas where temperature drops to 32 °F (0 °C) or below.	6212CH
Maintenance kit	Includes all hardware and material necessary to perform scheduled maintenance. Compatible with models EGENX20A and EGENX22A only.	6485CH
Bisque color paint kit	Ideal for touch-up paint/maintenance to generator enclosure against scratches and future corrosion.	EGENPAINT
Generator fascia	Enhances aesthetics. Installs in seconds (standard with EGENX20A and EGENX22A models).	EGENFASCIA
Air-cooled transportation cart	User-friendly assembly, attaches to lifting holes. Smart design allows only one person to lift the unit off of wooden pallet and position it for final installation.	EGENCART
<b>Monitoring</b>		
Mobile wireless remote monitor	Most advanced generator status monitoring system. Allows connectivity and settings programming via smart devices (laptops, smartphone, pad, etc.). Sends automated emails and/or text messages to multiple users. Requires cell phone signal and subscription.	EGENMOBILE
In-house wireless monitor	In-house generator status basic monitoring system. No computer connectivity required. 600 ft radius of wireless coverage.	EGENINHOME

**Table 7. Replacement parts—EGSX ATS**

Component	Catalog number				
	50 A	100 A	150 A	200 A	400 A
Contactors	99-5643-8	99-5638-12	99-5702-15	99-5702-15	99-5702-16
Wire harness ①	99-5643-7	99-5638-13	99-5702-17	99-5702-17	99-5702-18
Neutral bar	99-5643-6	99-5638-7	99-5702-6	99-5702-6	99-5702-13
Ground lugs	99-5643-4	99-5638-5	99-5702-4	99-5702-4	99-5702-4
Service entrance breaker	—	99-5638-4	CSR2150	CSR2200	KD2400
Contactors lugs	99-5643-5	99-5638-6	99-5702-5	99-5702-5	99-5702-12

① Includes relay and mounting base.

**Table 8. Replacement parts—EGSU ATS**

Component	Catalog number			
	100 A	150 A	200 A	400 A
Controller	RTC100	RTC100	RTC100	RTC100
Contactors	99-5638-12	99-5702-15	99-5702-15	99-5702-16
Wire harness	99-5638-14	99-5702-7	99-5702-7	99-5702-19
Service entrance breaker	99-5638-4	CSR2150	CSR2200	KD2400 ③
Ground bar	99-5638-5 ①	99-5702-4	99-5702-4	99-5702-4
Contactors lugs	99-5638-6	99-5702-5	99-5702-5	99-5702-12
Neutral bar	99-5638-7 ②	99-5702-6	99-5702-6	99-5702-13
Current sensors	CS200	CS200	CS200	CS400
Whole house surge protector	CHSPT2ULTRA	CHSPT2ULTRA	CHSPT2ULTRA	CHSPT2ULTRA

① For EGSU100L24RACA, order ground bar catalog number 99-5638-15.

② For EGSU100L24RACA, order neutral bar catalog number 99-5638-17.

③ For breaker lugs, order catalog number 2TA401K.

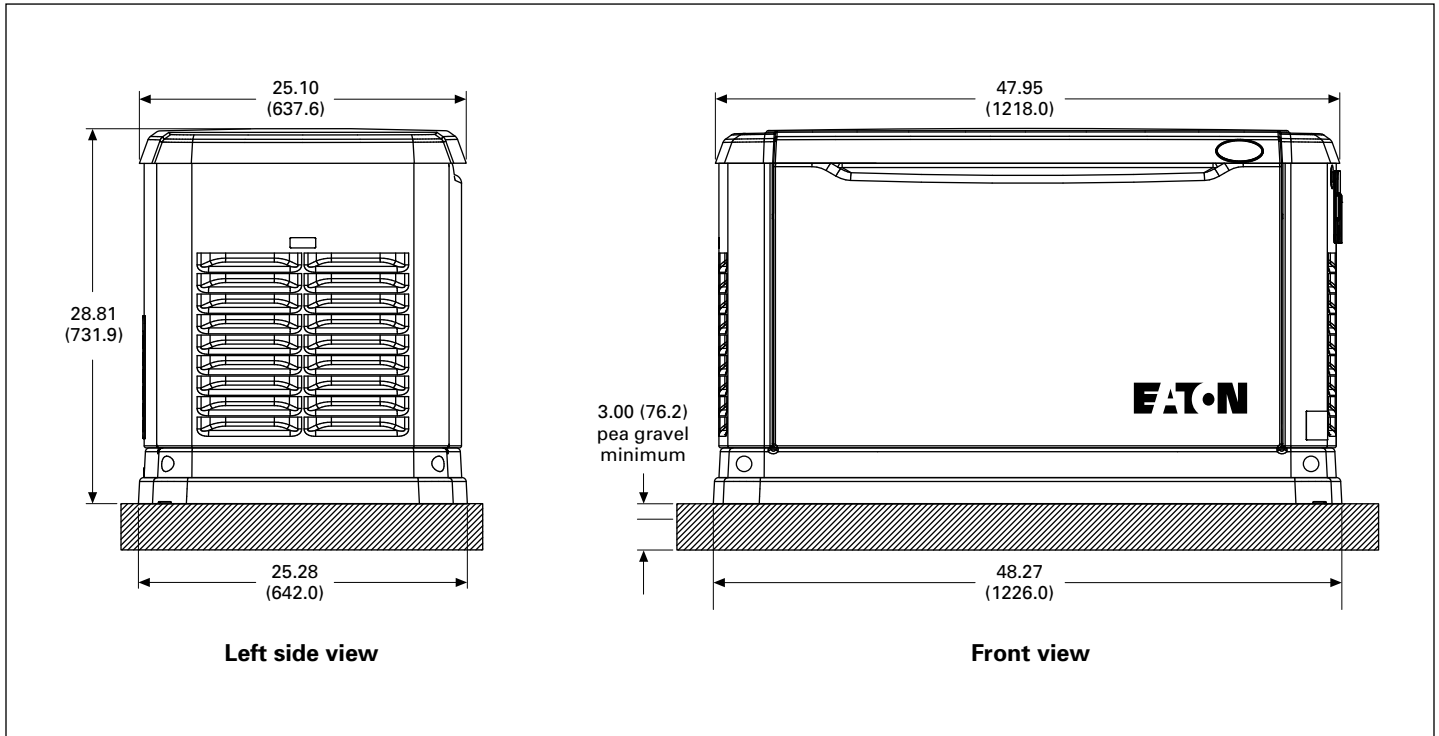

Figure 1. Air-cooled generator 20 and 22 kW—dimensions in inches (mm)

Dimensions shown are approximate. Design and specifications subject to change without notice. For additional information, visit our website at <http://generators.eaton.com>, call our technical resource center at (877) ETN-CARE (386-2273), or contact your local Eaton authorized distributor.

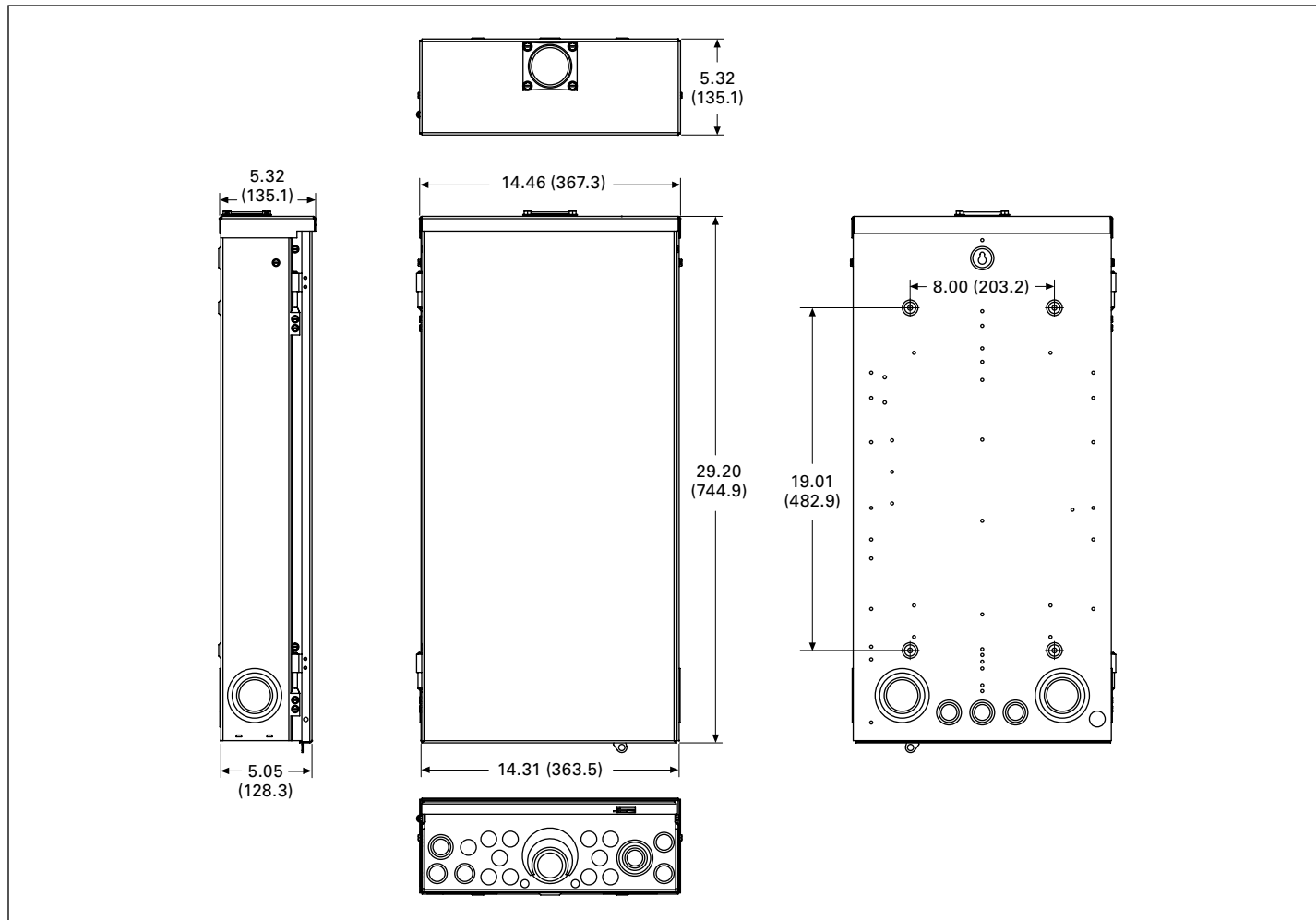

Figure 2. Plan view of an EGSX150NSEA/EGSX200NSEA—dimensions in inches (mm)

Table 9. Automatic transfer switches approximate dimensions in inches (mm)

Amperes	Width	Height	Depth	Weight in lb (kg)
50	14.25 (362.0)	21.00 (533.4)	4.00 (101.6)	23 (10.43)
100	14.46 (367.3)	16.87 (428.5)	5.32 (135.1)	25 (11.33)
100 with loadcenter	14.46 (367.3)	29.33 (745.0)	5.32 (135.1)	38 (17.23)
150	14.46 (367.3)	29.33 (745.0)	5.32 (135.1)	45 (20.41)
200 ①	14.46 (367.3)	29.33 (745.0)	5.32 (135.1)	45 (20.41)
400	23.14 (587.8)	37.56 (954.0)	10.00 (254.0)	130 (58.96)

① Height for 200 A non-SE is 25.08 (637.0).

**Eaton**  
 1000 Eaton Boulevard  
 Cleveland, OH 44122  
 United States  
 Eaton.com

© 2016 Eaton  
 All Rights Reserved  
 Printed in USA  
 Publication No. TD00405004E / Z17885  
 February 2016